



Installation Instructions

VENTAIR 3 in 1 Radio Frequency Remote Control
MODEL NO: V31RFR

Please read these instructions carefully before installing and using this product.

Keep these instructions handy for future reference.

WARNING:

When using this electrical appliance, basic safety precautions should always be followed to reduce the risk of fire, electric shock and personal injury.

INSTALLATION REQUIREMENTS:

- Must be installed by a Licensed Electrician.
- Must be installed according to the AS/NZS3000 wiring rules.
- Do not exceed the maximum wattage rating.
- Suitable for indoor use only.
- Suitable for most 3-in-1 Bathroom exhaust, heat, and light appliances.
- Ensure all outside wires are double insulated.

INSTALLATION TIPS:

- Always check for damage prior to installation.
- Do not operate/install any product which appears damaged in any way.
- If damaged, please return the complete product to the place of purchase for inspection, repair or replacement.
- Take care not to pull wires during unpacking as this may cause a bad connection.
- All electrical work should only commence after disconnection of the power. Remove fuses or turn off the circuit breaker to ensure all pole isolation of the electrical supply.

HOW TO INSTALL:

1) Install the Receiver box as per the wiring diagram shown in FIG 1.

Note: All electrical wiring must be carried out by a Licensed Electrician, and in accordance with the latest AS/NZS 3000 wiring rules.

Note: Ensure there's at least 30cm of clearance between the receiver box and any appliance or heat radiating surfaces to prevent it from overheating.

REMOTE BRACKET: Secure the bracket to a wall via double-sided tape or 2 screws.

2) Check remote controller operation.

FIG 1. – WIRING DIAGRAM

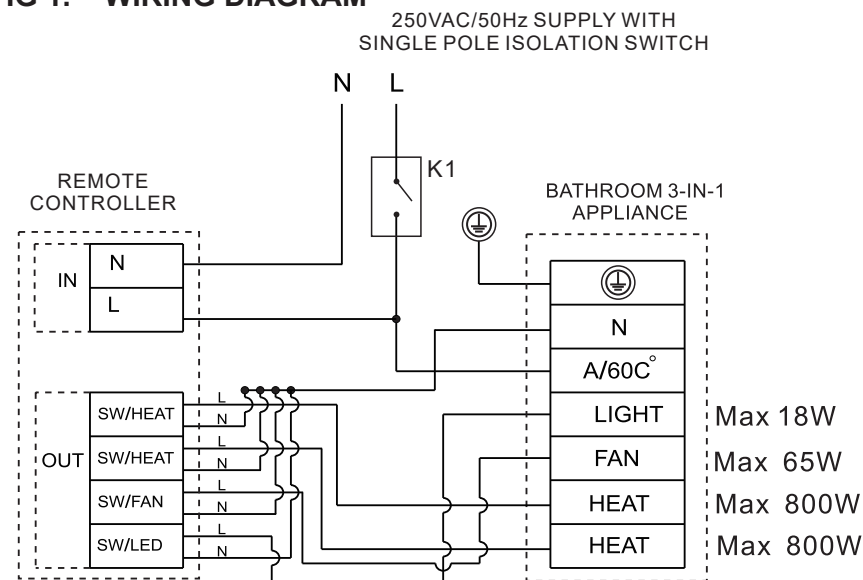

HOW TO USE REMOTE CONTROL:

NOTE: Your remote handpiece requires 2 x AAA size batteries (not included). Ensure battery polarities matches what is shown inside the battery compartment.

FAN Button: Press the Fan Button to switch the Exhaust Fan ON or OFF.

HEAT Button 1: Press to the Heat Button to switch the Heat Lamps ON or OFF.

HEAT Button 2: Press to the Heat Button to switch the Heat Lamps ON or OFF.

LIGHT Button: Press the Light Button to switch the Light ON or OFF.

PAIRING THE REMOTE: The supplied remote comes factory paired.

MANUAL PAIRING: Turn isolation switch off for a minimum of 1 minute.

Turn isolation switch back on and immediately press and hold all buttons for 3 seconds.

WARRANTY / SUPPORT: 12 Month replacement warranty.

Contact support@ventair.com.au or PH: (03) 9775 0556 for additional information.

ENVIRONMENT FRIENDLY DISPOSAL:

You can help protect the environment! Please remember to respect the local regulations. Hand in non-working electrical equipment to an appropriate waste disposal centre.

SPECIFICATIONS:

MODEL #	RATED VOLTAGE	RECOMMENDED APPLIANCE TYPE	RATED WATTAGE	SIGNAL TYPE
V31RFR	220-240V~ 50Hz	2 or 4 Heat Lamp Units	MAX 2200W	RF