

Led Mirror

800 Round V2

aquatica

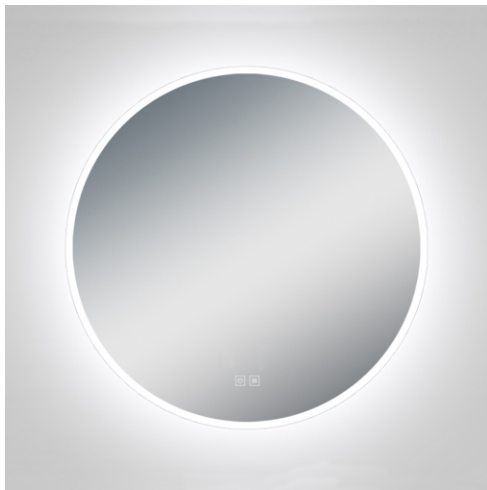
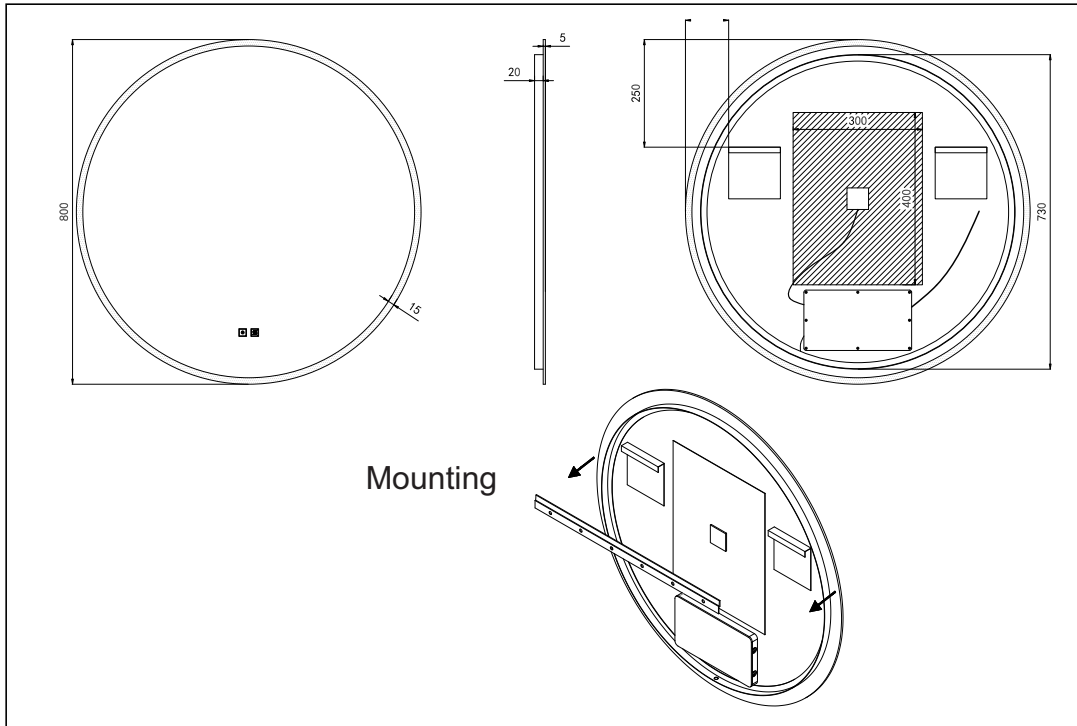

Code: MIRROR LED 800 RD V2

Key Features: Mirror with built-in LED & demister function

Shape: Round

Size: 800mm Ø x 25mm (T)

Light Control Options: Cool / Warm light

Switch Type: Touch sensor for light and demister control

Power Requirement: 230V AC

Installation: Screw mounting rail to wall, clip mirror onto rail

Note: Electrical connection from mirror to 230V is a terminal block. Must be hard wired by electrician.

Warranty: 2 years



KIWI OWNED COMPANY

NZ • DESIGNED
• ASSEMBLED
• TESTED

Aquatica NZ Limited

9 Saunders Place,
Avondale, Auckland.
Tel: 09-828 2068,
Fax: 09-828 2069
Email: info@aquatica.co.nz
or visit our website:
www.aquatica.co.nz

© copyright Aquatica 2019