



SEPTIC1000

FOOD WASTE DISPOSER

The SEPTIC1000 has two stage grind technology is perfect for a properly sized septic tank. Soundseal™ plus, making it a very quiet food waste disposer. Don't worry about what you can and can't grind... The SEPTIC1000 grinds nearly everything!



FEATURES



Dura-Drive™ Motor

The InSinkErator Dura-Drive motor is one of the most powerful and reliable on the market.



Built-In Air Switch

All InSinkErator's use air to turn the disposer on and off, making it safe around electricity.



Multigrind Plus™ 2 Stage Grinding

MultiGrind Plus™ 2 Stage Stainless Grinding System. This grinds the food waste into tiny particles that can easily be broken down in a septic system.



Soundseal Plus™ Noise Reduction

Makes the SEPTIC1000 a very quiet food waste disposer



Large Stainless Steel 1005ml Grind Chamber

Largest capacity of any domestic disposer on the market.



Quicklock™ Sink Mount

Makes it easy to install into the sink, and come with all models.



Made In The USA



Compact Design

The SEPTIC1000 has a compact design to fit under the bench where space is tight.



5 Year Warranty

The SEPTIC 1000 comes with a 5 year in-home warranty.

SPECIFICATIONS

Type of Feed	Continuous	Sound Technology	Anti-Vibration Mounting Technology and Tailpipe
On/Off	Control Wall Switch or Built-In Air Switch		Quiet Sink Baffle
Power Supply	Single Phase	Plug	Multi-Layer Sound Insulation
Reversing	Auto-Reverse Grind System		Stainless Steel Strainer Basket and Plug
Time Rating	Intermittent	Grind Chamber Capacity	1005 ml
Lubrication	Permanently Lubricated Upper & Lower Bearings	Motor Protection	Manual Reset Overload
Shipping Weight	8.8 kg (Approx.)	Average Water Usage	Approximately 4.0 L per Person per Day
Unit Finish	Black Enamel Grey TEN-1706	Average Electrical Usage	3-4 KWH per Annum
Overall Height	312 mm	Drain Connection	1-1/2" (3.81 cm) Anti-Vibration (Hose Clamp)
Grind Technology	2-Stage Grind Technology	Dishwasher Connection	Yes
Volts/Hz	HP	RPM	
220-240V, 50 Hz	.75	1425	

DIMENSIONS (MM)

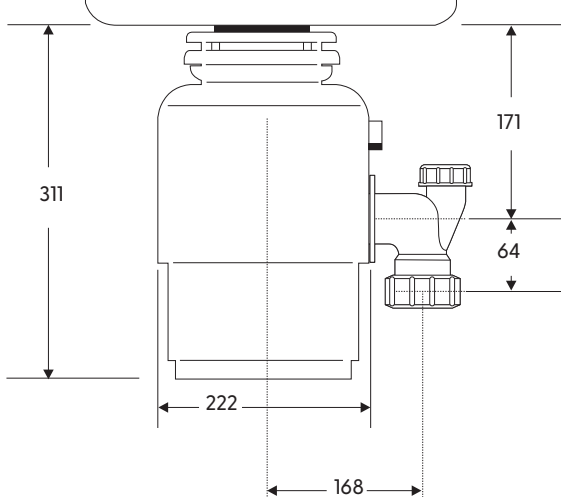

insinkerator.co.nz

For more information contact Parex Industries Limited on Tel: 0800 200 510 or email: info.parex@emerson.com

InSinkErator reserves the right to change product specifications without prior notice. The disposer described in this leaflet is for household use; usage in commercial situations is not covered by

