

PRODUCT SPECIFICATIONS

PACIFIC RISE 900 DOUBLE DWR FLOOR VANITY

NO HANDLE



CABINET

INSTALLATION	Floor standing
CONFIGURATION	2 soft-close drawers
MATERIAL	Moisture resistant board
WIDTH (mm)	890
DEPTH (mm)	450
HEIGHT (mm)	778
ORIGIN	Aotearoa / New Zealand

VANITY TOP

FINISH	Gloss White
MATERIAL	Vitreous China
TAP HOLE	Yes
OVERFLOW	Yes
WASTE SIZE	Suits 32mm and 40mm waste traps
WASTE INCLUDED	No
WIDTH (mm)	900
DEPTH (mm)	460
ORIGIN	PRC

PRODUCT CODES & FINISHES



4PAC090DF01NH
White Melamine



4PAC090DF23NH
Baroque



4PAC090DF93NH
Charred Oak

NOTES

- 5 year warranty *
- Cabinets made from moisture resistant board with PUR bonding technology are sustainably sourced from FSC certified NZ Radiata Pine.
- Optional - Pop-up Waste.**

JUNE 2024

ALL MEASUREMENTS ARE NOMINAL.
*WARRANTIES APPLY TO RESIDENTIAL DOMESTIC USE ONLY. WARRANTY IS VOID IF PRODUCT IS NOT INSTALLED ACCORDING TO OUR SPECIFICATIONS.
**REFER TO WEBSITE FOR FURTHER INFORMATION ON INSTALLATION GUIDE AND PRODUCT OPTIONS.
CLEARLITE.CO.NZ

TECHNICAL SPECIFICATIONS

PACIFIC RISE 900 DOUBLE DWR FLOOR VANITY

NO HANDLE

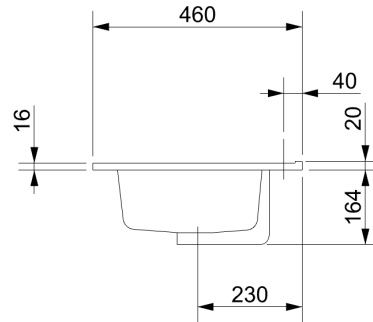
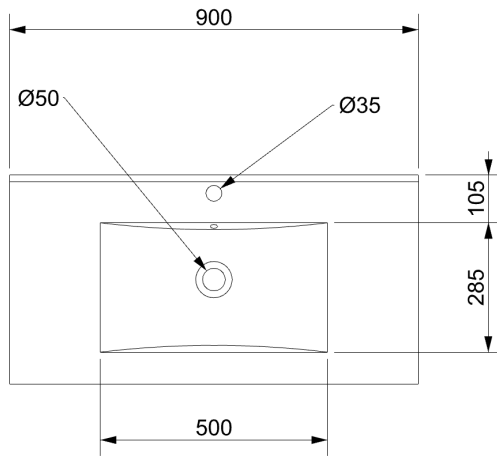

135 mm
INTERNAL BASIN DEPTH

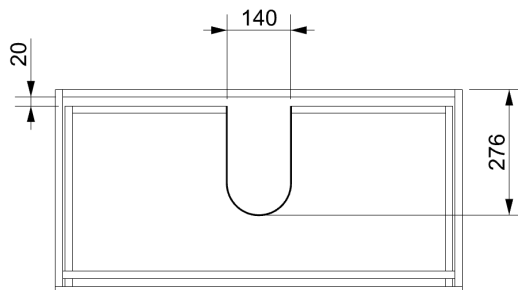
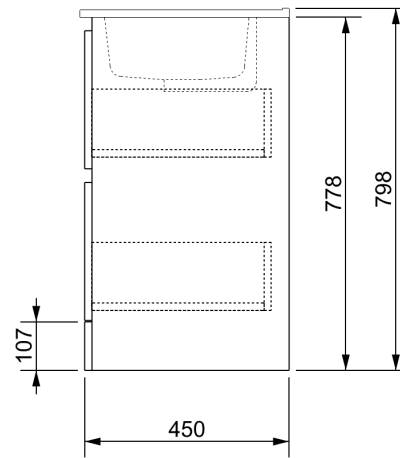
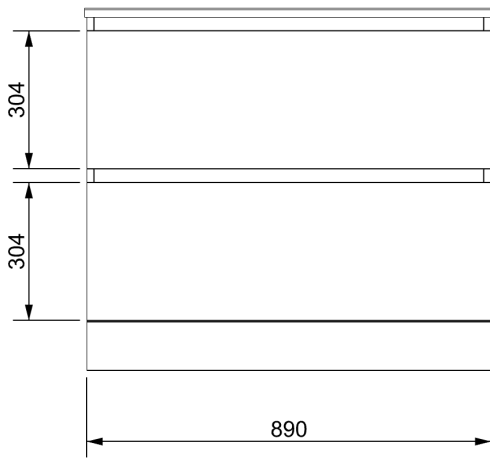
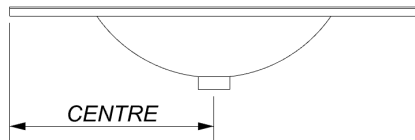

TOP & BOTTOM
DRAWER

JUNE 2024

ALL MEASUREMENTS ARE NOMINAL.
*WARRANTIES APPLY TO RESIDENTIAL DOMESTIC USE ONLY. WARRANTY IS VOID IF PRODUCT IS NOT INSTALLED ACCORDING TO OUR SPECIFICATIONS.
**REFER TO WEBSITE FOR FURTHER INFORMATION ON INSTALLATION GUIDE AND PRODUCT OPTIONS.
CLEARLITE.CO.NZ