

## Mecca Wall Mount Sensor Tap 80mm Plate



### SPECIFICATION

Description	Sensor Tap
Power	DC: 6V (4AA alkaline battery) AC: 220V-240V; 50/60HZ
Power Consumption	DC: Standby: $\leq 0.2\text{mW}$ AC: Standby: $\leq 2\text{W}$ ; Active: $\leq 4\text{W}$
Sensing Distance	15-30CM (base on 30X30CM white board)
Water Pressure	0.05MPa-0.7MPa
Temperature	1°C-55°C
Thread Specification	G1/2"
Flux	0.05-0.125L/s

### FINISH AND SKU

	MATTE BLACK
	NR405MB

### MAINTENANCE AND CARE

All surfaces should be cleaned with mild liquid detergent or soap and water. Do not use cream cleaners or citrus based cleaning products, as they are abrasive. Use of unsuitable cleaning agents may damage the surface. Any damage caused in this way will not be covered by warranty.

### PACKING INCLUDES

- 1x sensor tap
- 1x control box
- 1x power adapter
- 1x dressing ring
- 1x flexible hose
- 1x installation kit

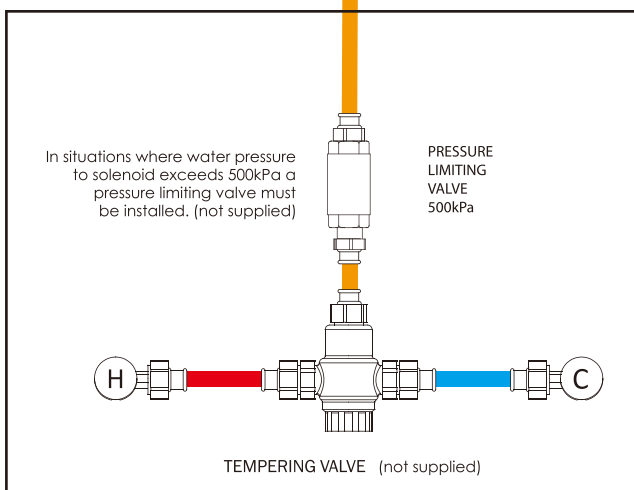
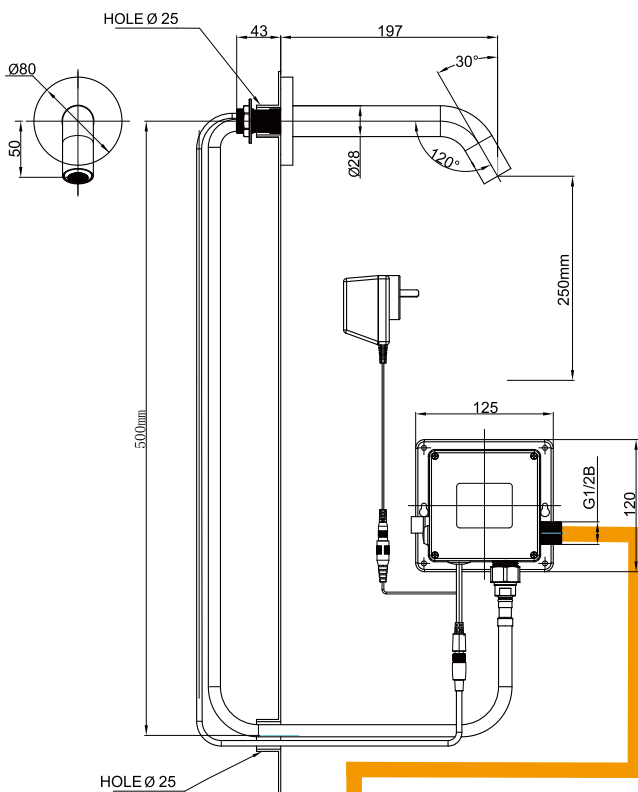

## Parts Name

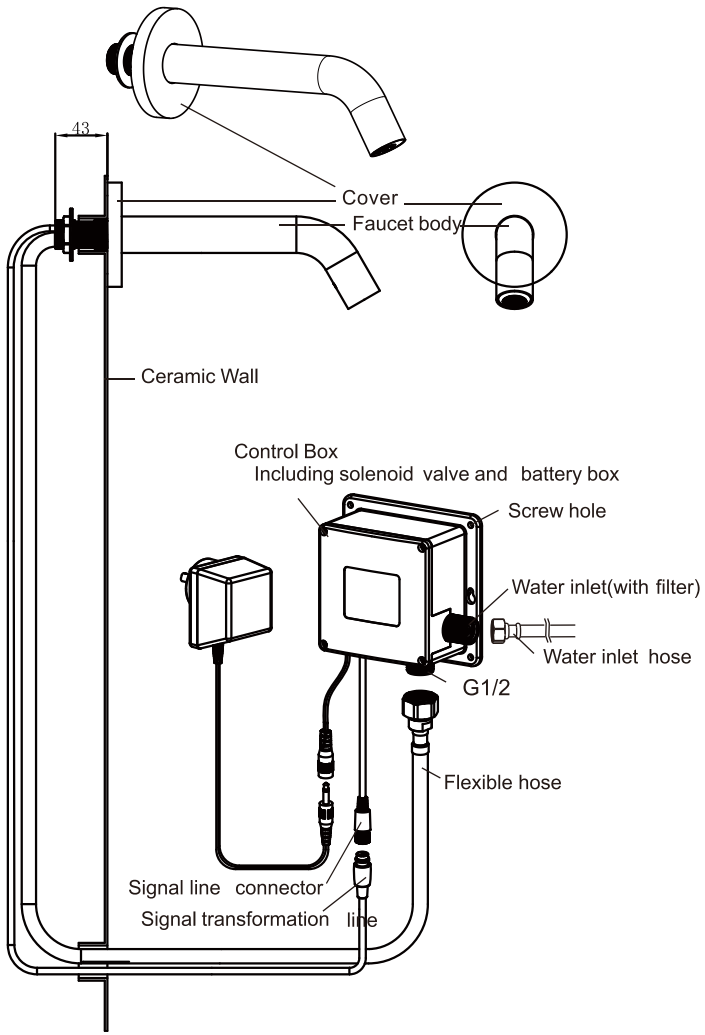

## Install Spout

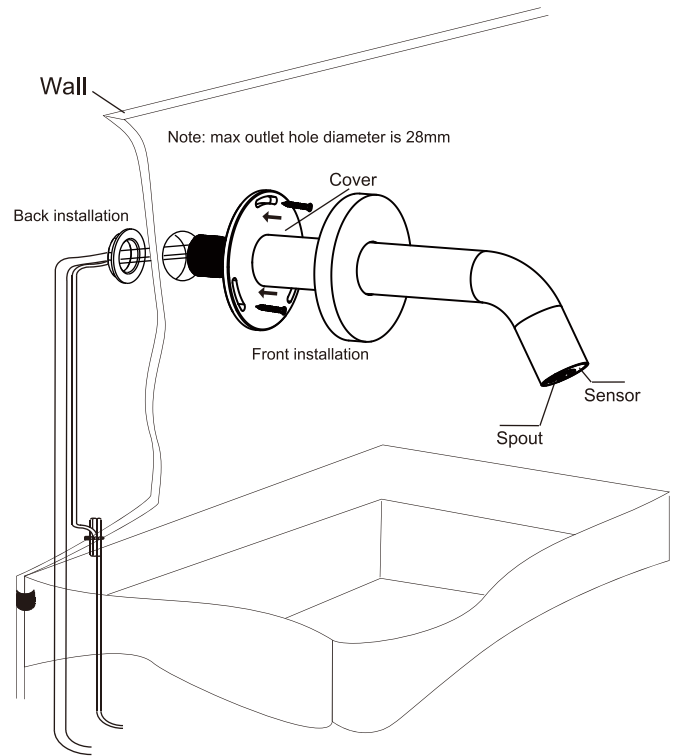

## Water connect

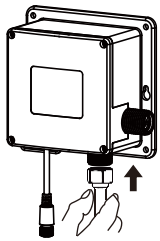

### 1. Water outlet hose connect

Connect the spout with control box by flexible hose,

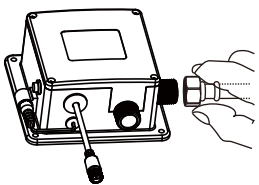

### 2. Water inlet hose connect

Connect G1/2 water supply hose with water inlet

**Note:** Be sure no water leakage after connecting water

## Signal line connect

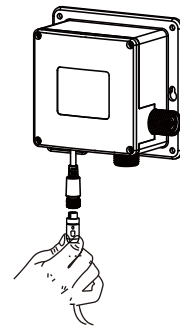

Connect signal line with control box, then screw tightly

**Note:** Should keep the signal line clear and dry, be sure to work normally

## Installation control box

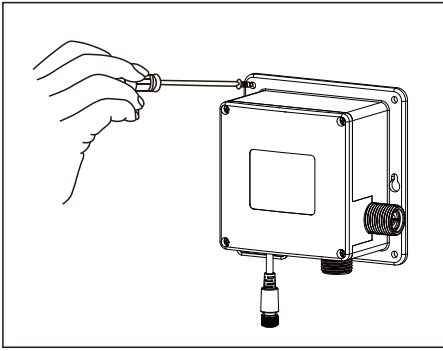

1.Put the control box on wall, drill four holes, then insert the plastic bulged tube

2.Fix the control box on wall by screw

### Note:

1.Please close the water supply and power supply before install.

2.Be sure to install control box correct, don't put upside down.

3.For easy to maintain, should be choose the suitable place install control box.

Meanwhile, It must less than 50cm distant from the basin.

(Please check the following picture)

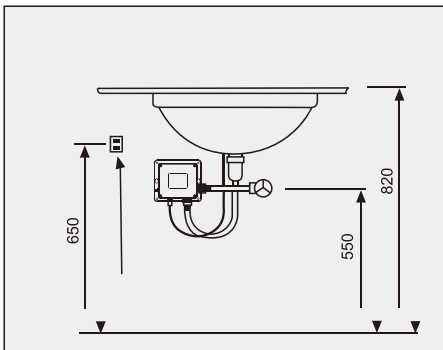

The installation drawing of control box

## Power connect

AC: Connect the transformer

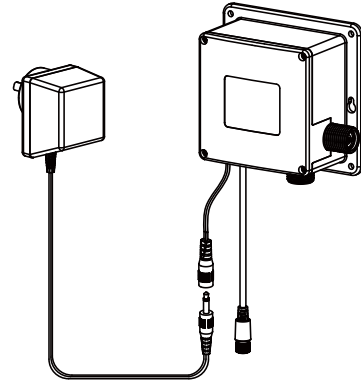

DC: Put in 4AA alkaline battery into the battery box.

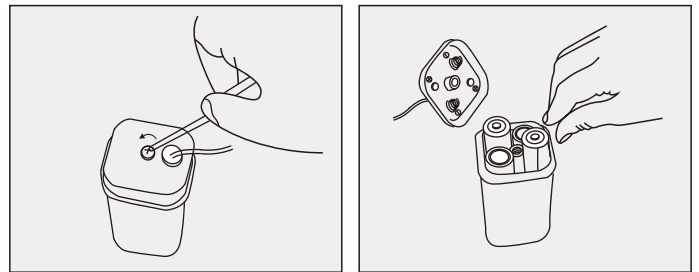

## Clear sensor window

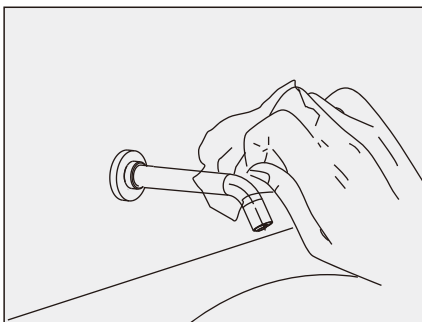

After installation, wipe sensor window by soft dry cloth to keep it clean

## Detect distance

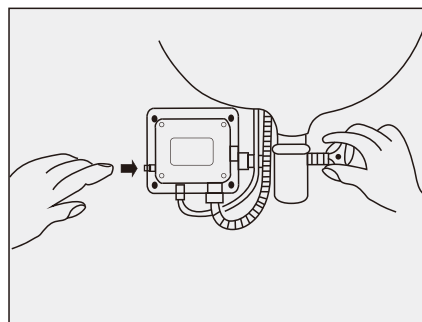

**ATTENTION :** After initial installation , pls remember to hold down the red reset button for 2 seconds to enable sensor to learn the IR distance to sink .

### Note:

It is normal if there is sound of opening & closing solenoid valve whe it is under self-adjustment condition.