

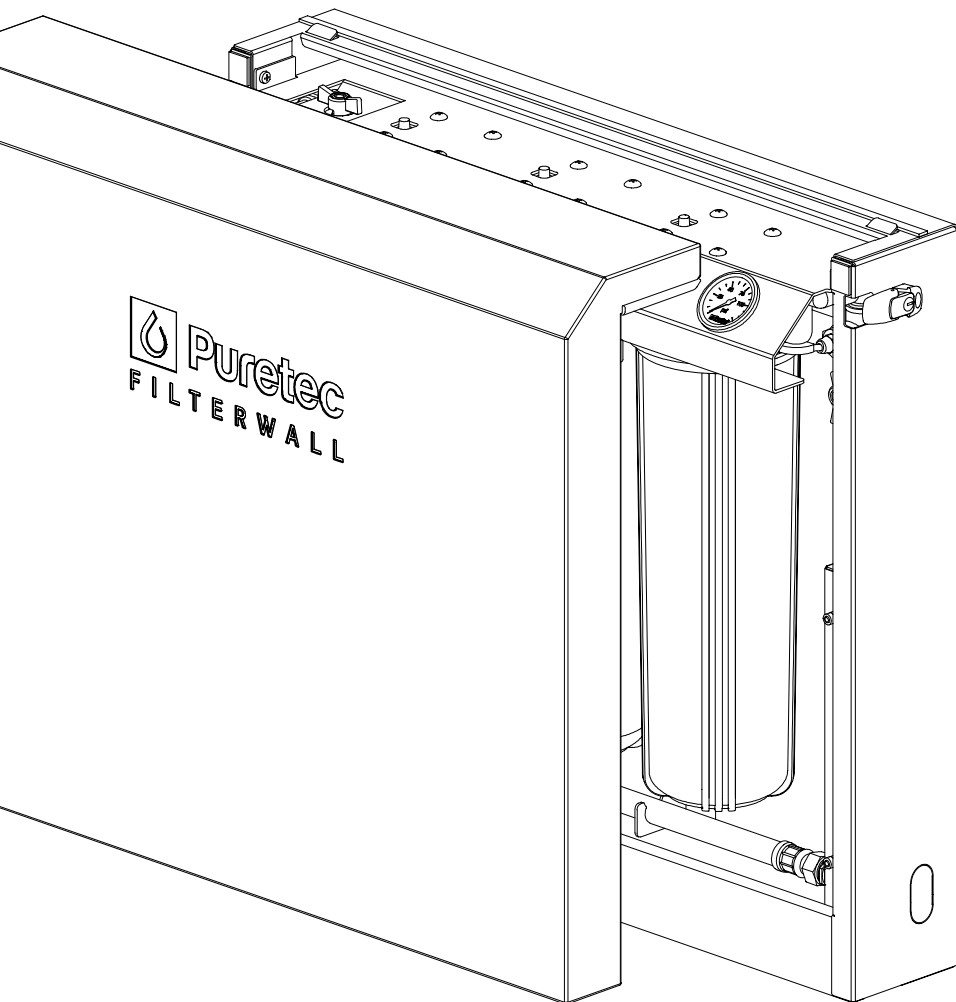

FilterWall™

F Series System Maintenance Guide



What's Inside

Important Information 3

Installation Record 4

Cartridge Replacement 4

Fig. 1 - Parts Diagram, Enclosure & Filter Assembly 6

Fig. 2 - Parts Diagram, Exploded View 7

Model Information 8

Warranty 14



WaterMark
AS3497
Licence No. WM 74617
Pro-Switch Pty Ltd

IMPORTANT INFORMATION!

Use Guidelines

- Use for mains water supply only.
 - Do not expose the system to temperatures below 0°C, protect from freezing.
 - The system must be installed according to local plumbing codes on the cold water line only.
 - This system requires regular replacement of the filter cartridges to maintain proper operation. Varying chlorine, sediment, or organic substance levels may affect the replacement frequency.
 - Be sure to change the filter cartridges every 6 - 12 months, or whenever you detect a change in taste, odour or a decrease in flow.
 - Minimum operating pressure: 200 kPa
 - Maximum operating pressure: 875 kPa
- Note:** Where line pressure exceeds 500 kPa, an approved pressure limiting device must be installed to comply with Australian & New Zealand Plumbing Standards. A 500 kPa pressure limiting device has been included with the FilterWall™ F3, F4, F5 & F6 models (not included with the F3E & F4E models).
- Maximum operating temperature: 52°C
 - Nominal flow rate: 30 - 55 Lpm (dependant on model)



Caution: Do not use water that is microbiologically unsafe or of unknown water quality without adequate disinfection before the system.

Installation Note: A water filter system/tap, like any product, has a limited life and may eventually fail. Also sometimes failure happens early due to unforeseen circumstances. To avoid possible property damage, this product should be regularly examined for leakage and/or deterioration and replaced when necessary. A drain pan, plumbed to an appropriate drain or outfitted with a leak detector, should be used in those applications where any leakage could cause property damage, and/or the water supply should be turned off if no one is home/present.

INSTALLATION MUST BE COMPLETED BY A LICENCED PLUMBER. FAULTY OPERATION DUE TO UNQUALIFIED PERSONS WILL RESULT IN VOIDED WARRANTY COVERAGE.

Installation Record

For future reference, fill in the following data:

Product Information	
Model Number:	
Purchased from:	
Date of Installation:	
Installer / Plumber Details:	

Cartridge Replacement

To maintain high-quality purified water, the filter cartridges need to be replaced every 6-12 months, depending on water quality and usage. An indication your filters need replacing is a decrease in water flow (filters are blocked with sediment and other containments) or bad taste and odour return. You can obtain replacement cartridges from your local Puretec dealer. To maintain performance standards and system warranty, use only genuine Puretec replacements.

Replacement Cartridge Codes;

Model	Stage 1	Stage 2	Stage 3
FILTERWALL-F3 / F3E	PL20MP1	PX05MP1	CB10MP1
FILTERWALL-F4 / F4E	PX05MP1	CB10MP1	SCALEGUARD-MP1
FILTERWALL-F5	PL20MP2	PX05MP2	CB10MP2
FILTERWALL-F6	PX05MP2	CB10MP2	SCALEGUARD-MP2

Model	Maintenance Kit Code (includes all 3 cartridges needed)
FILTERWALL-F3 / F3E	HR-F3 , includes PL20MP1, PX05MP1 & CB10MP1
FILTERWALL-F4 / F4E	HR-F4 , includes PX05MP1, CB10MP1 & SCALEGUARD-MP1
FILTERWALL-F5	HR-F5 , includes PL20MP2, PX05MP2 & CB10MP2
FILTERWALL-F6	HR-F6 , includes PX05MP2, CB10MP2 & SCALEGUARD-MP2

Cartridge Replacement Procedure

1. Isolate the water supply by ensuring the inlet shut off valve is in the CLOSE position. Open up a downstream tap to relieve pressure to the system.
2. Unscrew the filter bowls, using the spanner provided. **CAUTION:** Bowls will be heavy.
3. Remove and discard the used cartridges according to local laws.
4. Clean the bowls with soap and warm water, then rinse thoroughly.
5. Check the O-rings for damage and lubrication. If necessary, apply a light coating of food-grade silicone lubricant (or similar).

Note: Puretec recommends replacing the O-rings every 3-5 years to ensure the seal remains watertight and prevents any leaks.

Replacement O-ring ordering code: **MPOR-G**

6. Remove all packaging from the cartridges, including any wraps.
7. Place each cartridge into the filter bowl (see individual model information pages for cartridge order), ensuring the cartridges are centrally located in the bowl.
8. Hold each filter bowl upright from the bottom of the bowl while screwing into the filter head. Ensure the spigot in each housing head is located centrally to the cartridge to make a good seal and hand-tighten the bowl until firm. Use the supplied spanner to secure firmly (approx 1/4 turn), **DO NOT OVERTIGHTEN**.
9. Turn on the water supply by returning the inlet and outlet shut off valves to the OPEN position.
10. Check the system for leaks.
11. If leaks occur, repeat the steps to check cartridge alignment and bowl O-rings. If leaks persist, turn the inlet and outlet shut off valves to the CLOSE position and the bypass isolation to the OPEN position and call Puretec on 1300 140 140.

Note: Water will be unfiltered

12. When the system has been verified, allow the water to flow through the system by opening a downstream tap for 2 minutes to flush the system (this allows any air to be purged). Close the downstream tap. Your system is now ready for use.

Bypass Shut Off Valve

The bypass shut off valve should only be used during system failure/repair OR if the water supply cannot be disrupted. Using the bypass will mean the incoming water to the home/building will be unfiltered.

Fig. 1 - Parts Diagram, Enclosure & Filter Assembly

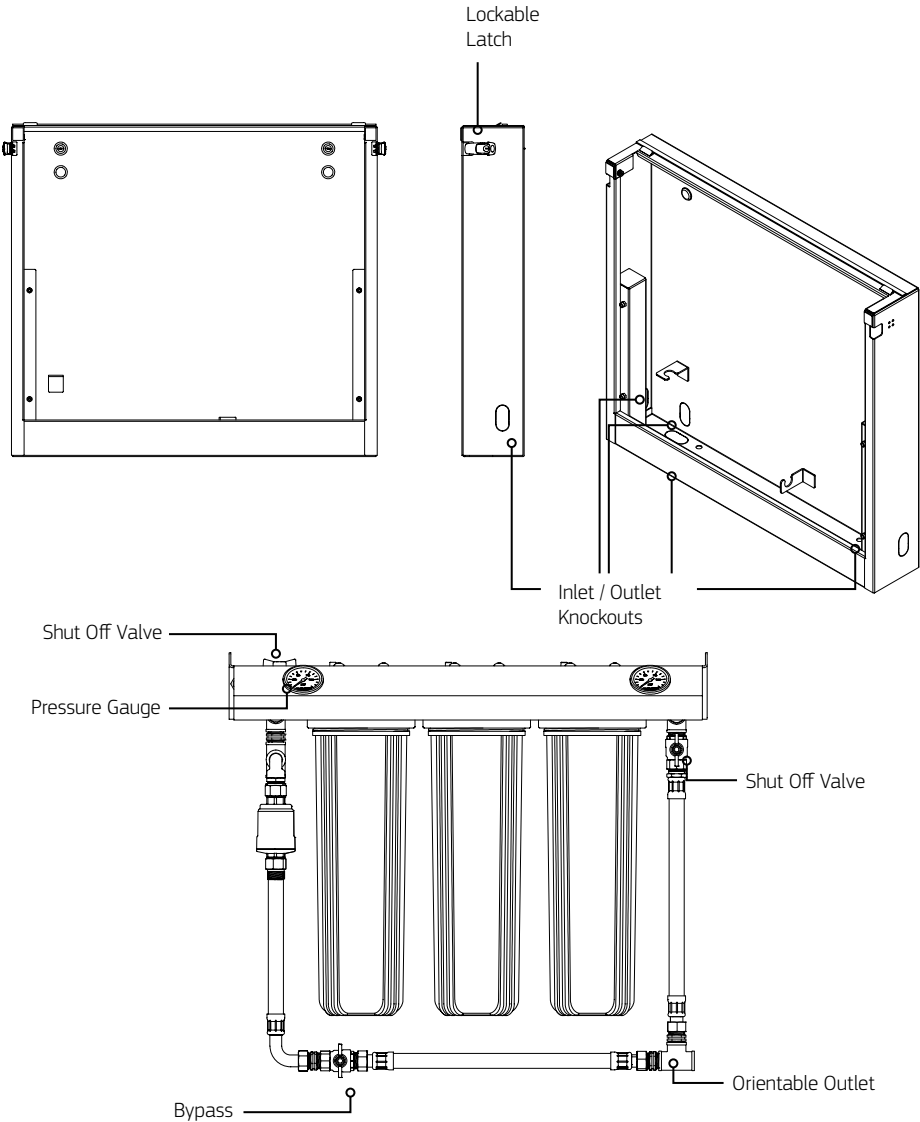

Note: Pressure Limiting Valve & Bypass Assembly not included with F3E & F4E models, see diagram on model information pages.

Fig. 2 - Parts Diagram, Exploded View

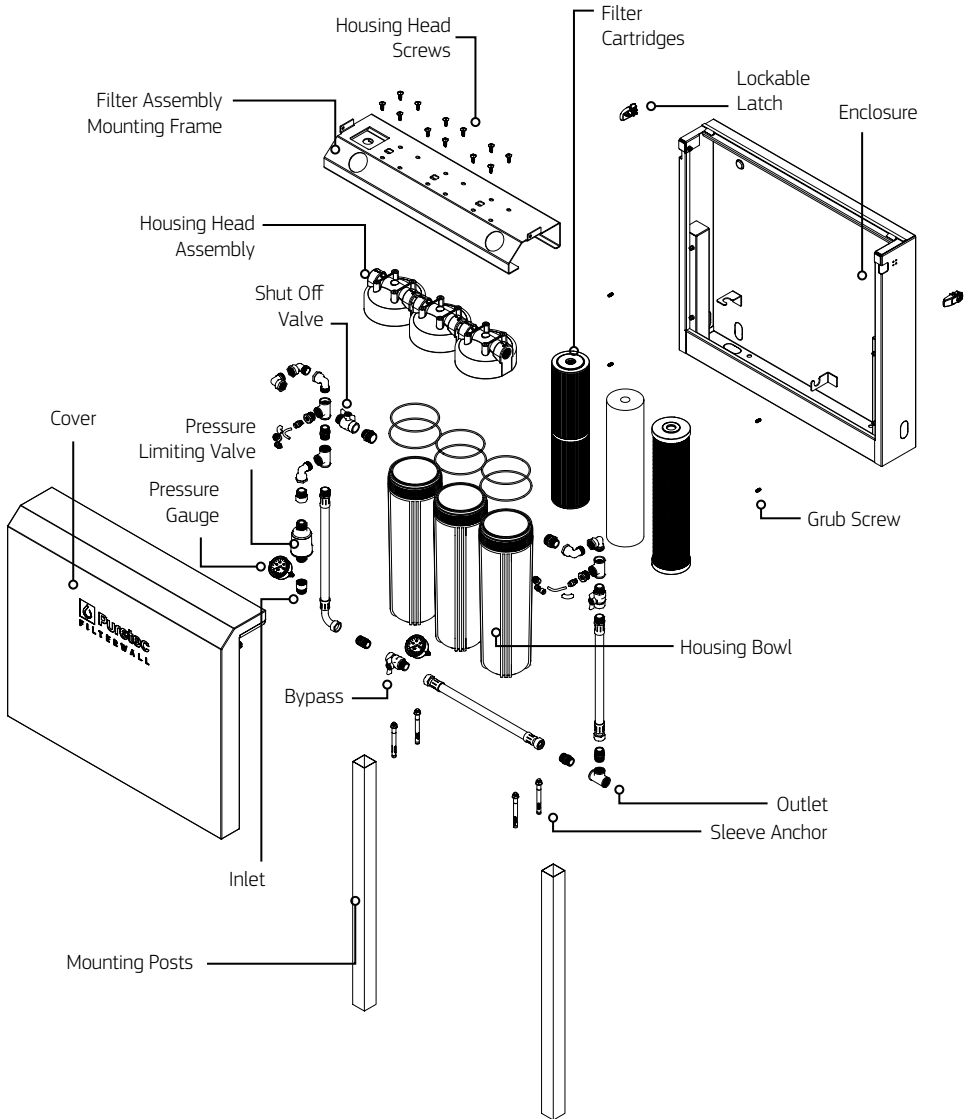

Note: Pressure Limiting Valve & Bypass Assembly not included with F3E & F4E models, see diagram on model information pages.

F3E Model Information

Specifications

Best Suited For:	Chlorine & Sediment Reduction
Nominal Flow Rate :	30 Lpm
Dimensions:	916 mm (W) x 580 mm (H) x 227 mm (D)
Micron Rating:	5 micron
Suitable Hardness Level:	<80
Min/Max Temperature:	0 - 52°C (protect from freezing)
Min/Max Pressure:	200 - 875* kPa
Min/Max pH:	6.5 - 8.5
Max Iron:	0.3 mg/l
Pressure Limited Valve:	-
Bypass:	-
Connection:	Inlet: 3/4" BSP Female Outlet: 3/4" BSP Female
Filter Cartridges	
1st Stage:	PL20MP1, 10" MaxiPlus™ Pleated Sediment
2nd Stage:	PX05MP1, 10" MaxiPlus™ Polyspun Sediment
3rd Stage:	CB10MP1, 10" MaxiPlus™ Carbon Block Taste & Odour

Note: Where line pressure exceeds 500 kPa, an approved pressure limiting device must be installed to comply with Australian & New Zealand Plumbing Standards. A 500 kPa pressure limiting device has been included in the FilterWall™ F3, F4, F5 & F6 models (not included with the F3E & F4E models).

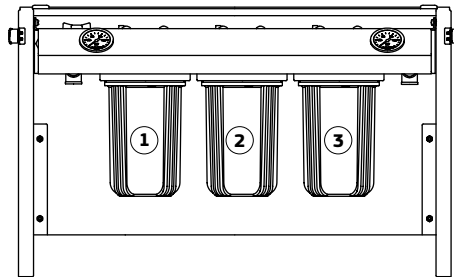
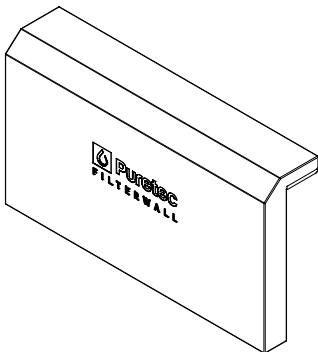

F3 Model Information

Specifications

Best Suited For:	Chlorine & Sediment Reduction
Nominal Flow Rate :	30 Lpm
Dimensions:	916 mm (W) x 580 mm (H) x 227 mm (D)
Micron Rating:	5 micron
Suitable Hardness Level:	<80
Min/Max Temperature:	0 - 52°C (protect from freezing)
Min/Max Pressure:	200 - 875* kPa
Min/Max pH:	6.5 - 8.5
Max Iron:	0.3 mg/l
Pressure Limited Valve:	Included
Bypass:	Included
Connection:	Inlet: 3/4" BSP Male Outlet: 3/4" BSP Female
Filter Cartridges	
1st Stage:	PL20MP1, 10" MaxiPlus™ Pleated Sediment
2nd Stage:	PX05MP1, 10" MaxiPlus™ Polyspun Sediment
3rd Stage:	CB10MP1, 10" MaxiPlus™ Carbon Block Taste & Odour

Note: Where line pressure exceeds 500 kPa, an approved pressure limiting device must be installed to comply with Australian & New Zealand Plumbing Standards. A 500 kPa pressure limiting device has been included in the FilterWall™ F3, F4, F5 & F6 models (not included with the F3E & F4E models).

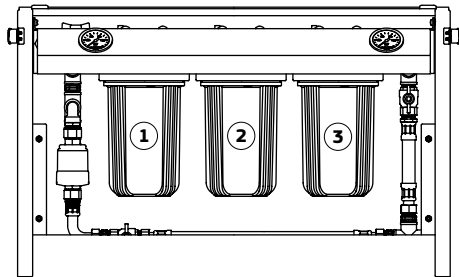
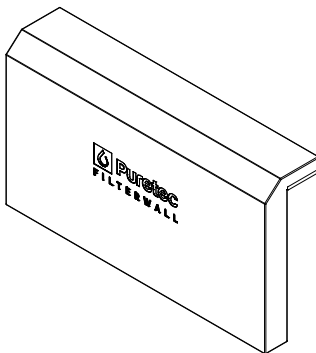

F4E Model Information

Specifications

Best Suited For:	Scale, Chlorine & Sediment Reduction
Nominal Flow Rate :	30 Lpm
Dimensions:	916 mm (W) x 580 mm (H) x 227 mm (D)
Micron Rating:	5 micron
Suitable Hardness Level:	80 - 140
Min/Max Temperature:	0 - 52°C (protect from freezing)
Min/Max Pressure:	200 - 875* kPa
Min/Max pH:	6.5 - 8.5
Max Iron:	0.3 mg/l
Pressure Limited Valve:	-
Bypass:	-
Connection:	Inlet: 3/4" BSP Female Outlet: 3/4" BSP Female
Filter Cartridges	
1st Stage:	PX05MP1, 10" MaxiPlus™ Polyspun Sediment
2nd Stage:	CB10MP1, 10" MaxiPlus™ Carbon Block Taste & Odour
3rd Stage:	SCALEGUARD-MP1, 10" MaxiPlus™ ScaleGuard

Note: Where line pressure exceeds 500 kPa, an approved pressure limiting device must be installed to comply with Australian & New Zealand Plumbing Standards. A 500 kPa pressure limiting device has been included in the FilterWall™ F3, F4, F5 & F6 models (not included with the F3E & F4E models).

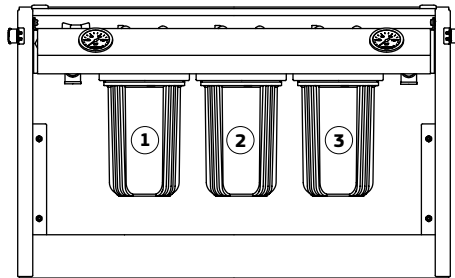
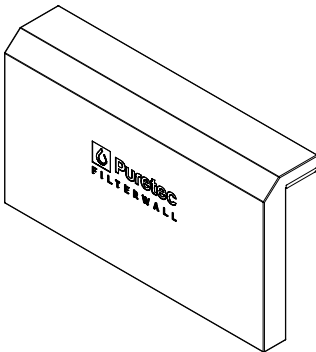

F4 Model Information

Specifications

Best Suited For:	Scale, Chlorine & Sediment Reduction
Nominal Flow Rate :	30 Lpm
Dimensions:	916 mm (W) x 580 mm (H) x 227 mm (D)
Micron Rating:	5 micron
Suitable Hardness Level:	80 - 140
Min/Max Temperature:	0 - 52°C (protect from freezing)
Min/Max Pressure:	200 - 875* kPa
Min/Max pH:	6.5 - 8.5
Max Iron:	0.3 mg/l
Pressure Limited Valve:	Included
Bypass:	Included
Connection:	Inlet: 3/4" BSP Male Outlet: 3/4" BSP Female
Filter Cartridges	
1st Stage:	PX05MP1, 10" MaxiPlus™ Polyspun Sediment
2nd Stage:	CB10MP1, 10" MaxiPlus™ Carbon Block Taste & Odour
3rd Stage:	SCALEGUARD-MP1, 10" MaxiPlus™ ScaleGuard

Note: Where line pressure exceeds 500 kPa, an approved pressure limiting device must be installed to comply with Australian & New Zealand Plumbing Standards. A 500 kPa pressure limiting device has been included in the FilterWall™ F3, F4, F5 & F6 models (not included with the F3E & F4E models).

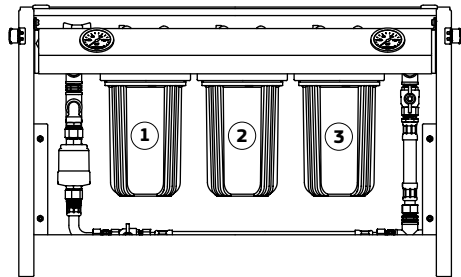
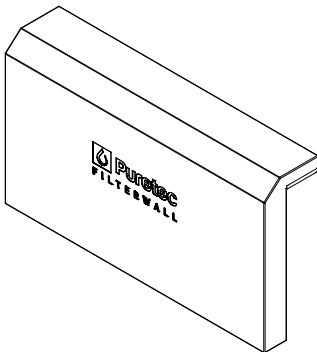

F5 Model Information

Specifications

Best Suited For:	Chlorine & Sediment Reduction
Nominal Flow Rate :	55 Lpm
Dimensions:	916 mm (W) x 825 mm (H) x 227 mm (D)
Micron Rating:	5 micron
Suitable Hardness Level:	>80
Min/Max Temperature:	0 - 52°C (protect from freezing)
Min/Max Pressure:	200 - 875* kPa
Min/Max pH:	6.5 - 8.5
Max Iron:	0.3 mg/l
Pressure Limited Valve:	Included
Bypass:	Included
Connection:	Inlet: 3/4" BSP Male Outlet: 3/4" BSP Female
Filter Cartridges	
1st Stage:	PL20MP2, 20" MaxiPlus™ Pleated Sediment
2nd Stage:	PX05MP2, 20" MaxiPlus™ Polyspun Sediment
3rd Stage:	CB10MP2, 20" MaxiPlus™ Carbon Block Taste & Odour

Note: Where line pressure exceeds 500 kPa, an approved pressure limiting device must be installed to comply with Australian & New Zealand Plumbing Standards. A 500 kPa pressure limiting device has been included in the FilterWall™ F3, F4, F5 & F6 models (not included with the F3E & F4E models).

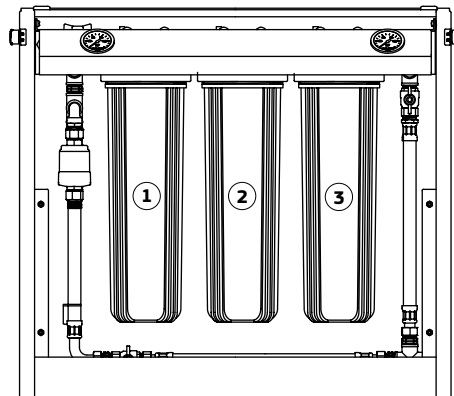
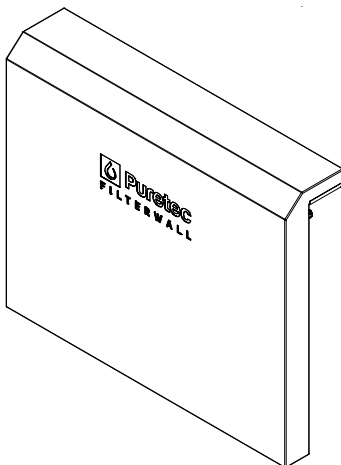

F6 Model Information

Specifications

Best Suited For:	Scale, Chlorine & Sediment Reduction
Nominal Flow Rate :	55 Lpm
Dimensions:	916 mm (W) x 825 mm (H) x 227 mm (D)
Micron Rating:	5 micron
Suitable Hardness Level:	80 - 140
Min/Max Temperature:	0 - 52°C (protect from freezing)
Min/Max Pressure:	200 - 875* kPa
Min/Max pH:	6.5 - 8.5
Max Iron:	0.3 mg/l
Pressure Limited Valve:	Included
Bypass:	Included
Connection:	Inlet: 3/4" BSP Male Outlet: 3/4" BSP Female
Filter Cartridges	
1st Stage:	PX05MP2, 20" MaxiPlus™ Polyspun Sediment
2nd Stage:	CB10MP2, 20" MaxiPlus™ Carbon Block Taste & Odour
3rd Stage:	SCALEGUARD-MP2, 20" MaxiPlus™ ScaleGuard

Note: Where line pressure exceeds 500 kPa, an approved pressure limiting device must be installed to comply with Australian & New Zealand Plumbing Standards. A 500 kPa pressure limiting device has been included in the FilterWall™ F3, F4, F5 & F6 models (not included with the F3E & F4E models).

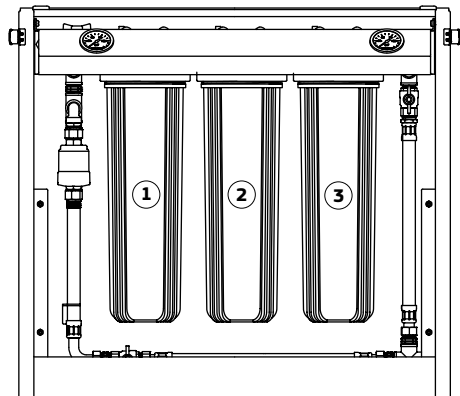
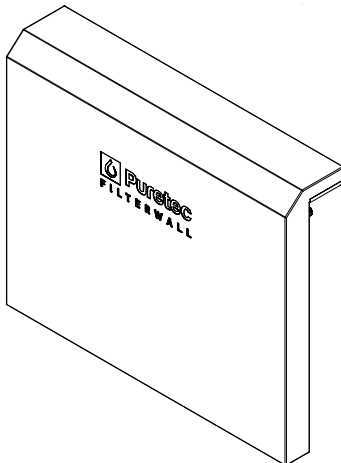

Warranty

Any claim under this warranty must be made within 10 years of the date of purchase of the product. This product is warranted to be free of defect of material and workmanship for 10 years from date of purchase.

Puretec is renowned for its quality and after-sales support so if you have any issues please call 1300 140 140 (AU) or 0800 130 140 (NZ). To make a warranty claim, contact us directly or the place of original purchase. All costs relating to a warranty claim must be approved by Puretec prior to any work being carried out.

10 year warranty is 1 year parts and labour plus 9 years parts only. Excludes cartridges. Puretec will pay your reasonable, direct expenses of claiming under this warranty. You may submit details and proof of your expense claim to place of purchase for consideration.

The warranty only applies if the product was used and/or installed in accordance with the user guide and/or installation instructions. This warranty is given in lieu of all other express or implied warranties and manufacturer shall in no circumstance be held liable for damages consequential or otherwise or delays caused or faulty manufacturing except as excluded by law.

Applicable to all above, is that the warranties need to be approved by Puretec to ensure product was not incorrectly used, installed or claimed. False and incorrect claims will be pursued at Puretec's discretion, including chargeable inspection and labour costs incurred.

Warranty/Australia

This warranty is given by Puretec Pty Ltd, ABN 44 164 806 688, 37-43 Brodie Road, Lonsdale SA 5160, telephone no. 1300 140 140 and email at sales@puretec.com.au.

This warranty is provided in addition to other rights and remedies you have under law: Our goods come with guarantees which cannot be excluded under the Australian Consumer Law. You are entitled to replacement or refund for a major failure and to compensation for other reasonably foreseeable loss or damage. You are also entitled to have the goods repaired or replaced if the goods fail to be of acceptable quality and the failure does not amount to a major failure.

Warranty/New Zealand

This warranty is given by Puretec NZ LP, Reg. No 50081773, PO Box 875 Cambridge 3450 NZ, telephone no. 0800 130 140 and email at sales@puretec.co.nz.

This warranty is provided in addition to other rights and remedies you have under law: Our goods come with guarantees which cannot be excluded under the Consumer Guarantees Act. You are entitled to replacement or refund for a major failure and to compensation for other reasonably foreseeable loss or damage. You are also entitled to have the goods repaired or replaced if the goods fail to be of acceptable quality and the failure does not amount to a major failure.

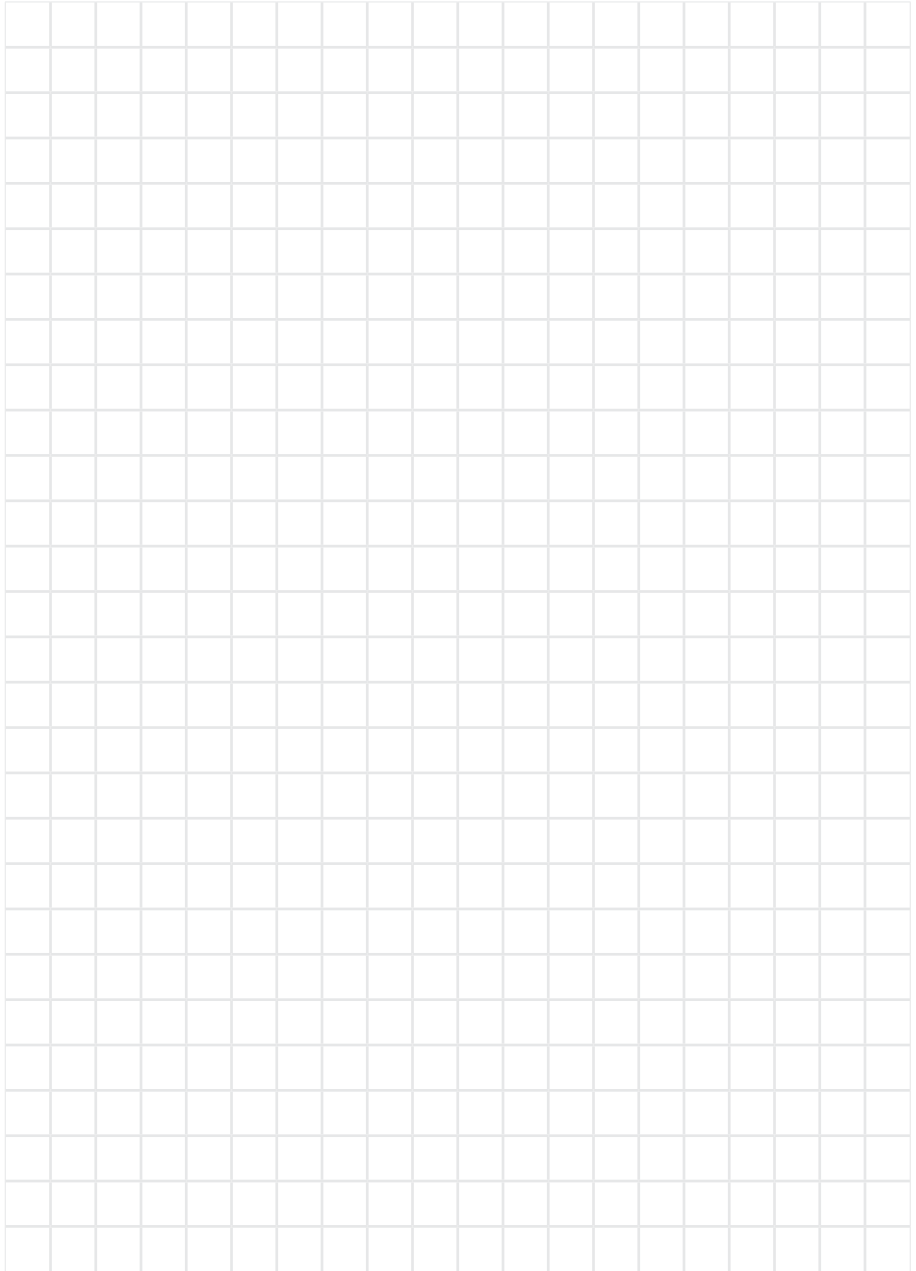



AUSTRALIA

P 1300 140 140
E sales@puretec.com.au
W puretec.com.au

NEW ZEALAND

P 0800 130 140
E sales@puretec.co.nz
W puretec.co.nz