

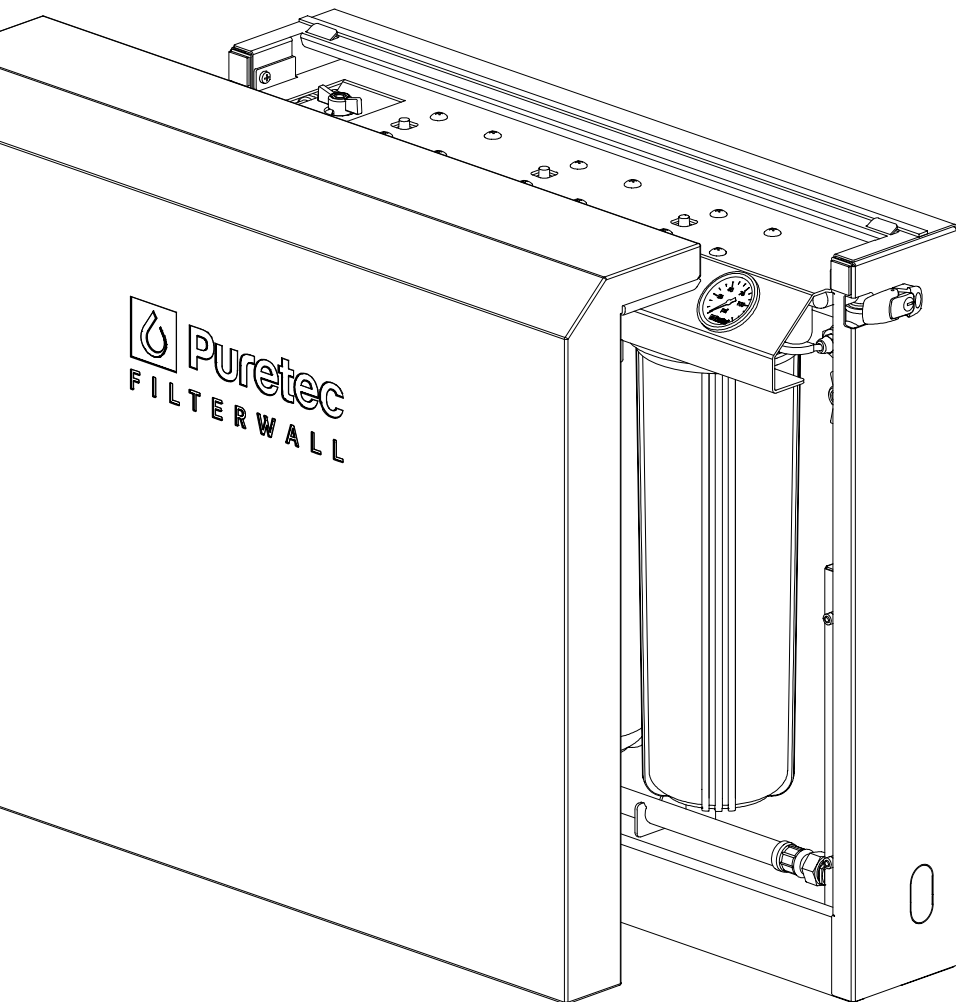

FilterWall™

F Series System Installation Guide



What's Inside

Important Information	3
Preparing Your System	4
Installation Requirements	5
Installation Record	5
Fig. 1 - Dimensions, 10" Models	6
Fig. 2 - Dimensions, 20" Models	7
Fig. 3 - Parts Diagram, Enclosure & Filter Assembly	8
Fig. 4 - Parts Diagram, Exploded View	9
Model Information	10
Installation Instructions	16
Warranty	20



WaterMark

AS3497

Licence No. WM 74617

Pro-Switch Pty Ltd

IMPORTANT INFORMATION!

Use Guidelines

- Use for mains water supply only.
 - Do not expose the system to temperatures below 0°C, protect from freezing.
 - The system must be installed according to local plumbing codes on the cold water line only.
 - This system requires regular replacement of the filter cartridges to maintain proper operation. Varying chlorine, sediment, or organic substance levels may affect the replacement frequency.
 - Be sure to change the filter cartridges every 6 - 12 months, or whenever you detect a change in taste, odour or a decrease in flow.
 - Minimum operating pressure: 200 kPa
 - Maximum operating pressure: 875 kPa
- Note:** Where line pressure exceeds 500 kPa, an approved pressure limiting device must be installed to comply with Australian & New Zealand Plumbing Standards. A 500 kPa pressure limiting device has been included with the FilterWall™ F3, F4, F5 & F6 models (not included with the F3E & F4E models).
- Maximum operating temperature: 52°C
 - Nominal flow rate: 30 - 55 Lpm (dependant on model)



Caution: Do not use water that is microbiologically unsafe or of unknown water quality without adequate disinfection before the system.

Installation Note: A water filter system/tap, like any product, has a limited life and may eventually fail. Also sometimes failure happens early due to unforeseen circumstances. To avoid possible property damage, this product should be regularly examined for leakage and/or deterioration and replaced when necessary. A drain pan, plumbed to an appropriate drain or outfitted with a leak detector, should be used in those applications where any leakage could cause property damage, and/or the water supply should be turned off if no one is home/present.

INSTALLATION MUST BE COMPLETED BY A LICENCED PLUMBER. FAULTY OPERATION DUE TO UNQUALIFIED PERSONS WILL RESULT IN VOIDED WARRANTY COVERAGE.

Preparing Your System

Thank you for purchasing a Puretec quality product. Puretec systems are designed to run economically for many years, dependent on the initial installation and periodical maintenance.

Please read all instructions carefully as failures caused by incorrect installation or operation are not covered by warranty.

On removing your system from its carton, you should check all the components to ensure all are present and have not been damaged in transportation.

Remove all the packing materials prior to use.

As a responsible manufacturer we care about the environment. We urge you to follow the correct disposal procedure for your product and packaging materials and the disposal of any material according to local laws and regulations.

Depending on your model, you should have the following:

- FilterWall™ System Enclosure & Filter Assembly
- Installation Guide
- Spanner
- Home Owners Pack, inc Set of Keys (for latches)
- Mounting Posts
- 4 x M8 x 16mm Grub Screws
- 4 x M10 x 100mm Sleeve Anchors

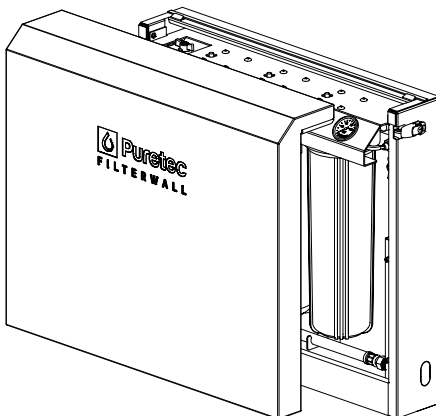
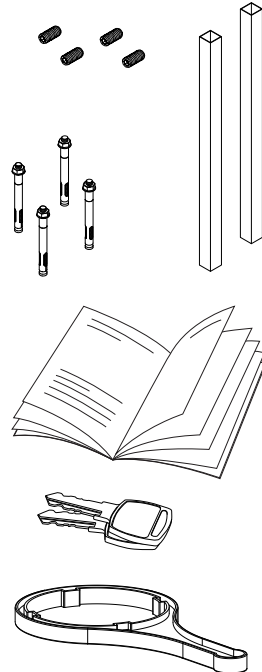

Installation Requirements

- When selecting an installation location; the enclosure and system should be protected from harsh environments where overexposure to excessive heat, direct sunlight, saltwater spray, snow, direct contact with water and freezing conditions can occur. Choose a location with adequate drainage and where water spillage will not cause damage.
 - Suitable installation position. Installation must be on a flat, level and well supported surface.
 - Ensure the position chosen best suits where the system can be connected to your cold water inlet.
 - Consider installation options: If installing using a bolted method a smooth concrete slab will be required. For a post mounted installation the included mounting posts can be used to install in a garden bed (or similar). For a wall mounted installation holes may be drilled into the rear of the enclosure.
 - Connect to the cold water line only (20 mm copper or PEX).
 - Ensure supply pressure is between 200 - 875 kPa
- Note:** Where line pressure exceeds 500 kPa, an approved pressure limiting device must be installed to comply with Australian & New Zealand Plumbing Standards. A 500 kPa pressure limiting device has been included in the FilterWall™ F3, F4, F5 & F6 models (not included with the F3E & F4E models).
- Select suitable inlet and outlet connectors 20 mm BSP (not supplied).

Installation Record

For future reference, fill in the following data:

Product Information	
Model Number:	
Purchased from:	
Date of Installation:	
Installer / Plumber Details:	

Fig. 1 - Dimensions, 10" Models

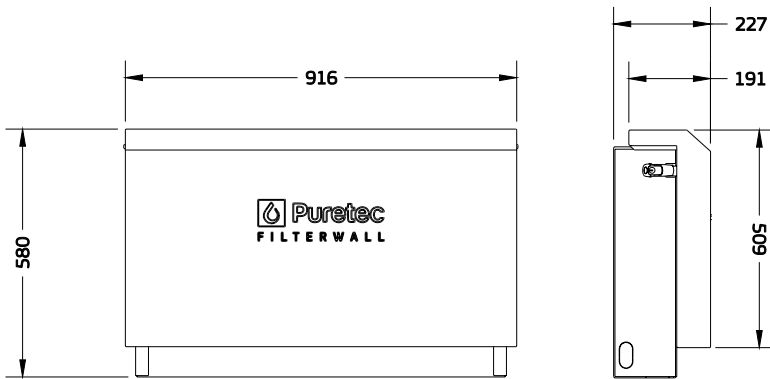

FRONT VIEW W/ COVER

SIDE VIEW W/ COVER

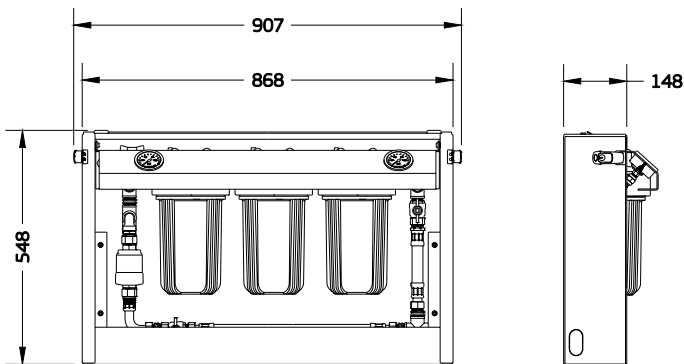

FRONT VIEW W/O COVER

SIDE VIEW W/O COVER

All dimensions are shown in millimetres.

Note: Pressure Limiting Valve & Bypass Assembly not included with F3E & F4E models, see diagram on model information pages.

Fig. 2 - Dimensions, 20" Models

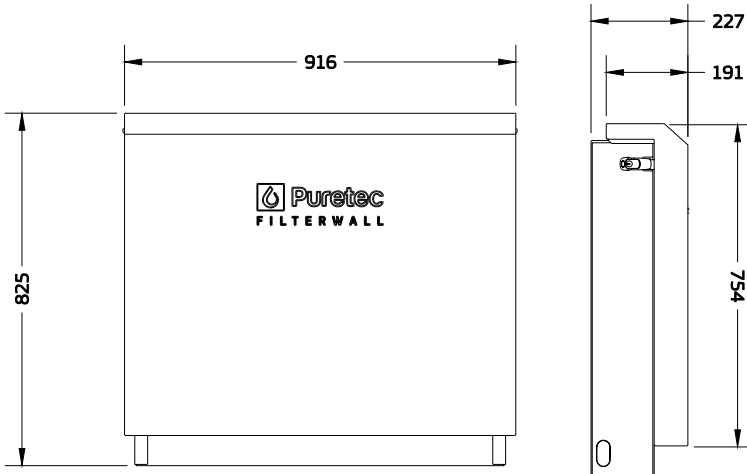

FRONT VIEW W/ COVER

SIDE VIEW W/ COVER

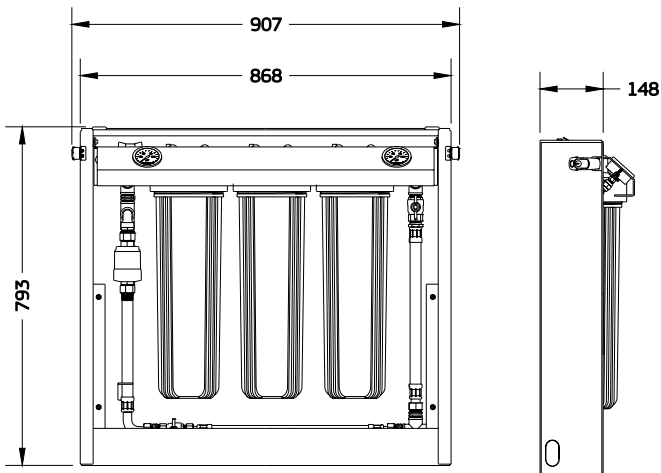

FRONT VIEW W/O COVER

SIDE VIEW W/O COVER

Note: Pressure Limiting Valve & Bypass Assembly not included with F3E & F4E models, see diagram on model information pages.

Fig. 3 - Parts Diagram, Enclosure & Filter Assembly

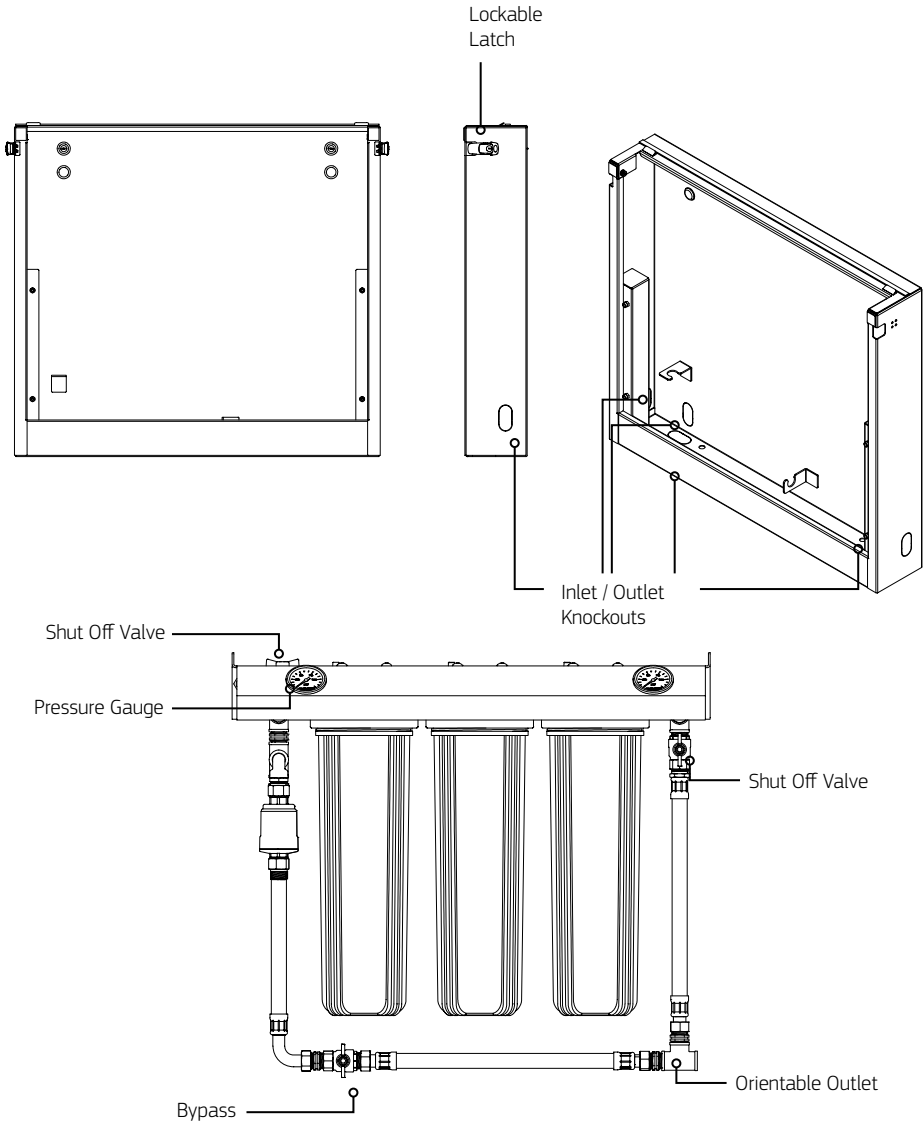

Note: Pressure Limiting Valve & Bypass Assembly not included with F3E & F4E models, see diagram on model information pages.

Fig. 4 - Parts Diagram, Exploded View

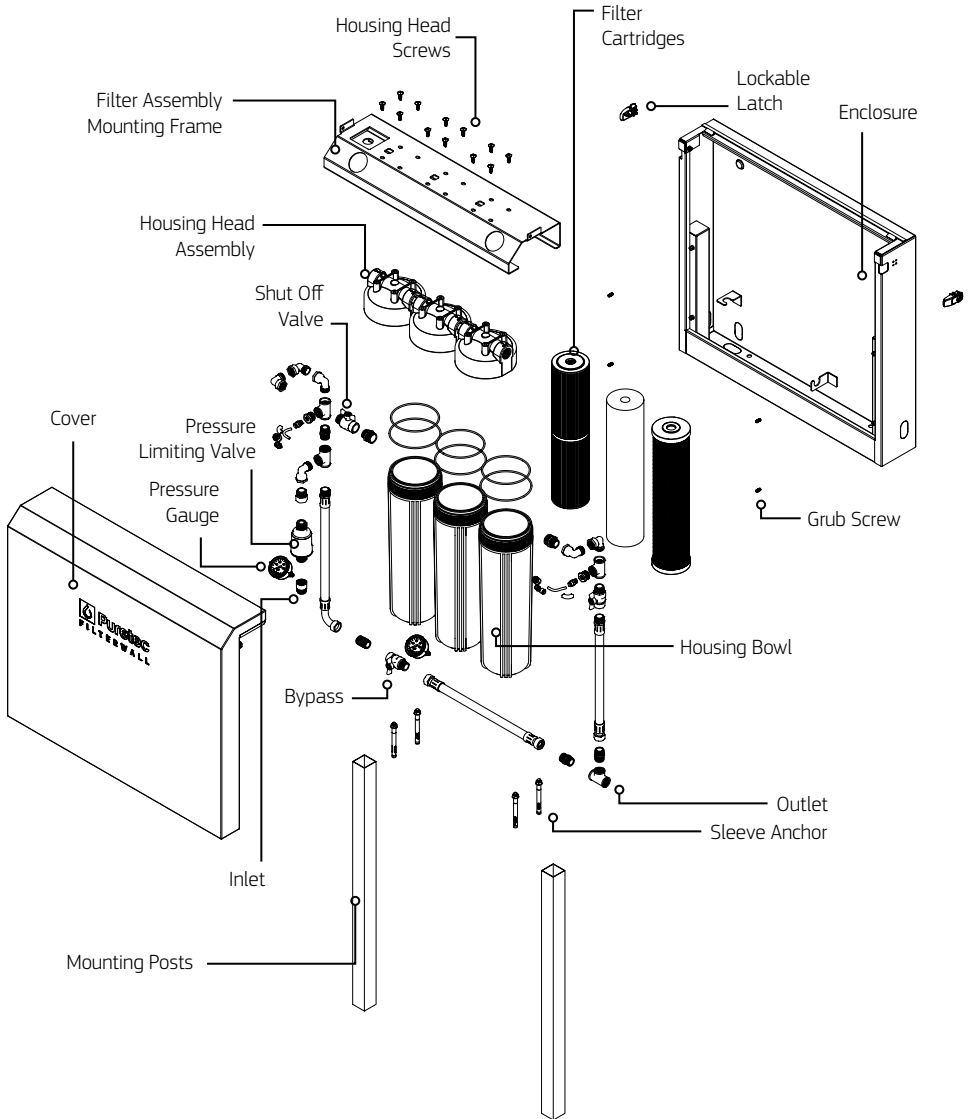

Note: Pressure Limiting Valve & Bypass Assembly not included with F3E & F4E models, see diagram on model information pages.

F3E Model Information

Specifications

Best Suited For:	Chlorine & Sediment Reduction
Nominal Flow Rate :	30 Lpm
Dimensions:	916 mm (W) x 580 mm (H) x 227 mm (D)
Micron Rating:	5 micron
Suitable Hardness Level:	<80
Min/Max Temperature:	0 - 52°C (protect from freezing)
Min/Max Pressure:	200 - 875* kPa
Min/Max pH:	6.5 - 8.5
Max Iron:	0.3 mg/l
Pressure Limited Valve:	-
Bypass:	-
Connection:	Inlet: 3/4" BSP Female Outlet: 3/4" BSP Female
Filter Cartridges	
1st Stage:	PL20MP1, 10" MaxiPlus™ Pleated Sediment
2nd Stage:	PX05MP1, 10" MaxiPlus™ Polyspun Sediment
3rd Stage:	CB10MP1, 10" MaxiPlus™ Carbon Block Taste & Odour

Note: Where line pressure exceeds 500 kPa, an approved pressure limiting device must be installed to comply with Australian & New Zealand Plumbing Standards. A 500 kPa pressure limiting device has been included in the FilterWall™ F3, F4, F5 & F6 models (not included with the F3E & F4E models).

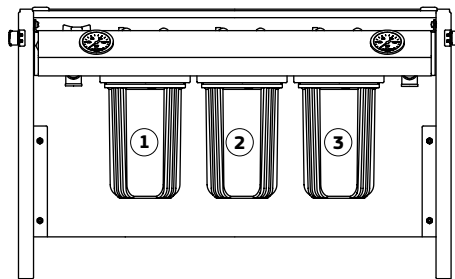
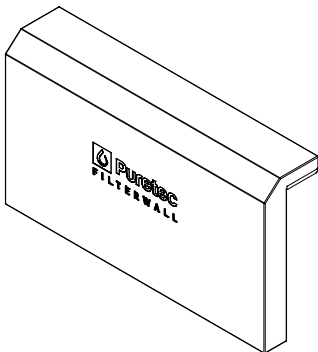

F3 Model Information

Specifications

Best Suited For:	Chlorine & Sediment Reduction
Nominal Flow Rate :	30 Lpm
Dimensions:	916 mm (W) x 580 mm (H) x 227 mm (D)
Micron Rating:	5 micron
Suitable Hardness Level:	<80
Min/Max Temperature:	0 - 52°C (protect from freezing)
Min/Max Pressure:	200 - 875* kPa
Min/Max pH:	6.5 - 8.5
Max Iron:	0.3 mg/l
Pressure Limited Valve:	Included
Bypass:	Included
Connection:	Inlet: 3/4" BSP Male Outlet: 3/4" BSP Female
Filter Cartridges	
1st Stage:	PL20MP1, 10" MaxiPlus™ Pleated Sediment
2nd Stage:	PX05MP1, 10" MaxiPlus™ Polyspun Sediment
3rd Stage:	CB10MP1, 10" MaxiPlus™ Carbon Block Taste & Odour

Note: Where line pressure exceeds 500 kPa, an approved pressure limiting device must be installed to comply with Australian & New Zealand Plumbing Standards. A 500 kPa pressure limiting device has been included in the FilterWall™ F3, F4, F5 & F6 models (not included with the F3E & F4E models).

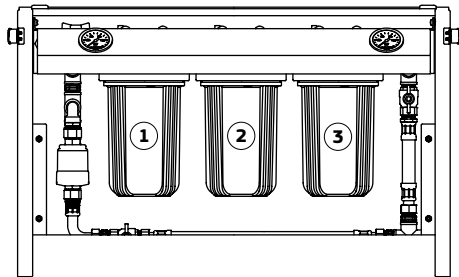
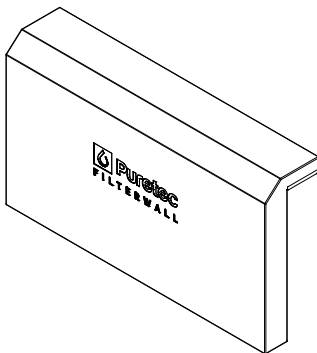

F4E Model Information

Specifications

Best Suited For:	Scale, Chlorine & Sediment Reduction
Nominal Flow Rate :	30 Lpm
Dimensions:	916 mm (W) x 580 mm (H) x 227 mm (D)
Micron Rating:	5 micron
Suitable Hardness Level:	80 - 140
Min/Max Temperature:	0 - 52°C (protect from freezing)
Min/Max Pressure:	200 - 875* kPa
Min/Max pH:	6.5 - 8.5
Max Iron:	0.3 mg/l
Pressure Limited Valve:	-
Bypass:	-
Connection:	Inlet: 3/4" BSP Female Outlet: 3/4" BSP Female
Filter Cartridges	
1st Stage:	PX05MP1, 10" MaxiPlus™ Polyspun Sediment
2nd Stage:	CB10MP1, 10" MaxiPlus™ Carbon Block Taste & Odour
3rd Stage:	SCALEGUARD-MP1, 10" MaxiPlus™ ScaleGuard

Note: Where line pressure exceeds 500 kPa, an approved pressure limiting device must be installed to comply with Australian & New Zealand Plumbing Standards. A 500 kPa pressure limiting device has been included in the FilterWall™ F3, F4, F5 & F6 models (not included with the F3E & F4E models).

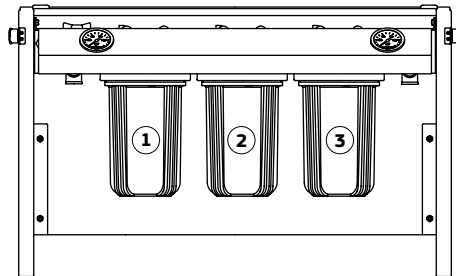
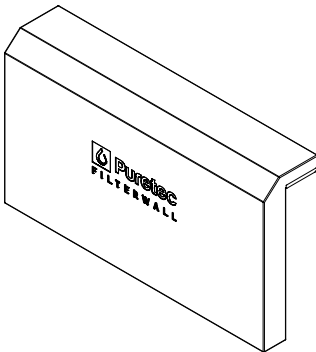

F4 Model Information

Specifications

Best Suited For:	Scale, Chlorine & Sediment Reduction
Nominal Flow Rate :	30 Lpm
Dimensions:	916 mm (W) x 580 mm (H) x 227 mm (D)
Micron Rating:	5 micron
Suitable Hardness Level:	80 - 140
Min/Max Temperature:	0 - 52°C (protect from freezing)
Min/Max Pressure:	200 - 875* kPa
Min/Max pH:	6.5 - 8.5
Max Iron:	0.3 mg/l
Pressure Limited Valve:	Included
Bypass:	Included
Connection:	Inlet: 3/4" BSP Male Outlet: 3/4" BSP Female
Filter Cartridges	
1st Stage:	PX05MP1, 10" MaxiPlus™ Polyspun Sediment
2nd Stage:	CB10MP1, 10" MaxiPlus™ Carbon Block Taste & Odour
3rd Stage:	SCALEGUARD-MP1, 10" MaxiPlus™ ScaleGuard

Note: Where line pressure exceeds 500 kPa, an approved pressure limiting device must be installed to comply with Australian & New Zealand Plumbing Standards. A 500 kPa pressure limiting device has been included in the FilterWall™ F3, F4, F5 & F6 models (not included with the F3E & F4E models).

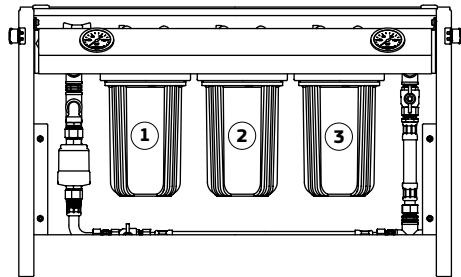
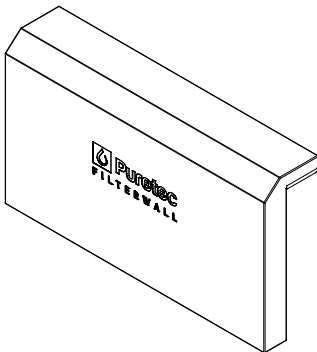

F5 Model Information

Specifications

Best Suited For:	Chlorine & Sediment Reduction
Nominal Flow Rate :	55 Lpm
Dimensions:	916 mm (W) x 825 mm (H) x 227 mm (D)
Micron Rating:	10 micron
Suitable Hardness Level:	>80
Min/Max Temperature:	0 - 52°C (protect from freezing)
Min/Max Pressure:	200 - 875* kPa
Min/Max pH:	6.5 - 8.5
Max Iron:	0.3 mg/l
Pressure Limited Valve:	Included
Bypass:	Included
Connection:	Inlet: 3/4" BSP Male Outlet: 3/4" BSP Female
Filter Cartridges	
1st Stage:	PL20MP2, 20" MaxiPlus™ Pleated Sediment
2nd Stage:	PX05MP2, 20" MaxiPlus™ Polyspun Sediment
3rd Stage:	CB10MP2, 20" MaxiPlus™ Carbon Block Taste & Odour

Note: Where line pressure exceeds 500 kPa, an approved pressure limiting device must be installed to comply with Australian & New Zealand Plumbing Standards. A 500 kPa pressure limiting device has been included in the FilterWall™ F3, F4, F5 & F6 models (not included with the F3E & F4E models).

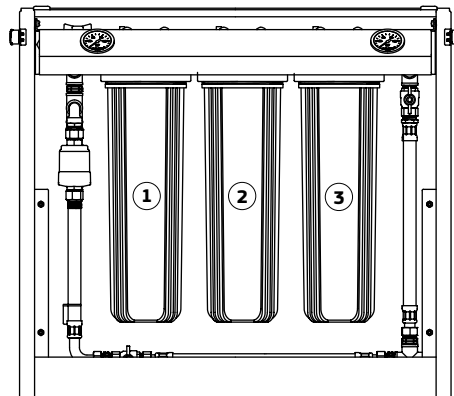
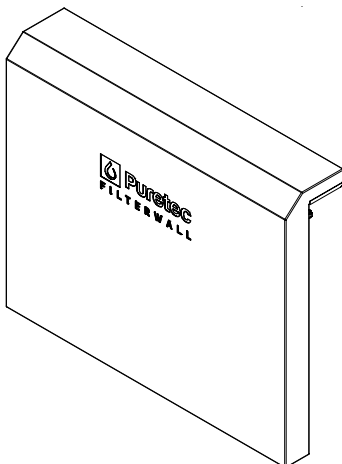

F6 Model Information

Specifications

Best Suited For:	Scale, Chlorine & Sediment Reduction
Nominal Flow Rate :	55 Lpm
Dimensions:	916 mm (W) x 825 mm (H) x 227 mm (D)
Micron Rating:	5 micron
Suitable Hardness Level:	80 - 140
Min/Max Temperature:	0 - 52°C (protect from freezing)
Min/Max Pressure:	200 - 875* kPa
Min/Max pH:	6.5 - 8.5
Max Iron:	0.3 mg/l
Pressure Limited Valve:	Included
Bypass:	Included
Connection:	Inlet: 3/4" BSP Male Outlet: 3/4" BSP Female
Filter Cartridges	
1st Stage:	PX05MP2, 20" MaxiPlus™ Polyspun Sediment
2nd Stage:	CB10MP2, 20" MaxiPlus™ Carbon Block Taste & Odour
3rd Stage:	SCALEGUARD-MP2, 20" MaxiPlus™ ScaleGuard

Note: Where line pressure exceeds 500 kPa, an approved pressure limiting device must be installed to comply with Australian & New Zealand Plumbing Standards. A 500 kPa pressure limiting device has been included in the FilterWall™ F3, F4, F5 & F6 models (not included with the F3E & F4E models).

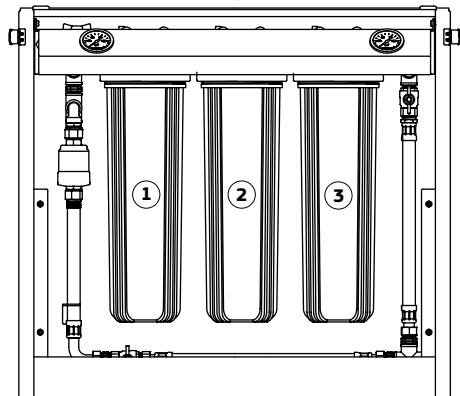
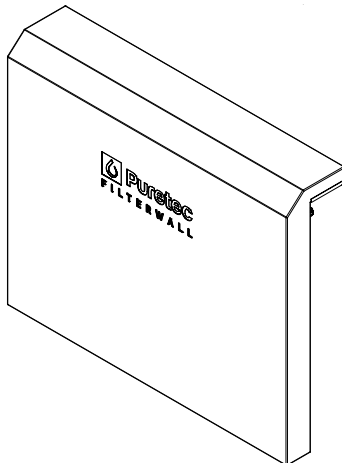

Installation Instructions

The following instructions are a guide only. The installer is responsible to ensure it complies with any local regulations that may be applicable for this type of installation.

When selecting an installation location; the enclosure and system should be protected from harsh environments where overexposure to excessive heat, direct sunlight, saltwater spray, snow, direct contact with water and freezing conditions can occur.

Choose a location with adequate drainage and where water spillage will not cause damage.

Installation must be on a flat, level and well supported surface.

1. Now that you have removed everything from its packaging, Check the front panel of the enclosure for any damage (including latches) that may have occurred during transit.
2. Unlock the latches on the front panel and remove the front cover by lifting upwards, then pulling away from the enclosure (keys supplied in the spanner bag).
3. Inspect the filtration assembly for any damage that may have occurred during transit.
4. Plan out the installation location and plumbing lines. There is provision for 4 different inlet locations in the unit (1 rear, 1 side, and 2 bottom), and 3 different outlet locations (1 rear, 1 side and 1 bottom).

Note: Should the plumbing utilise the bottom knockouts, it is advised to knock them out now. Whilst wearing gloves, using a screwdriver and mallet, a firm hit to the knockout should dislodge the knockout panel. The burrs can be appropriately filed smooth.

5. To improve access and reduce the weight of the system, you will need to remove the housing bowls and cartridges from the system. If the bowls are difficult to undo, the spanner provided may be used to make it easier.

Note: Take note of the order the cartridges are in to ensure when they are re-installed they are in the same order.

6. The FilterWall™ F series is specifically designed for freestanding installation which can be achieved using the supplied sleeve anchors or mounting posts. Alternatively, the unit can be wall mounted, however, provision to do so has not been included.

Bolted Installation

Where a flat smooth concrete surface is available the unit can be mounted utilising the supplied sleeve anchors.

7. Drill the holes for the anchors into the platform or slab. Locate the anchor holes inside the bottom of the unit and secure the unit utilising the supplied sleeve anchors.
8. Proceed to step 23.

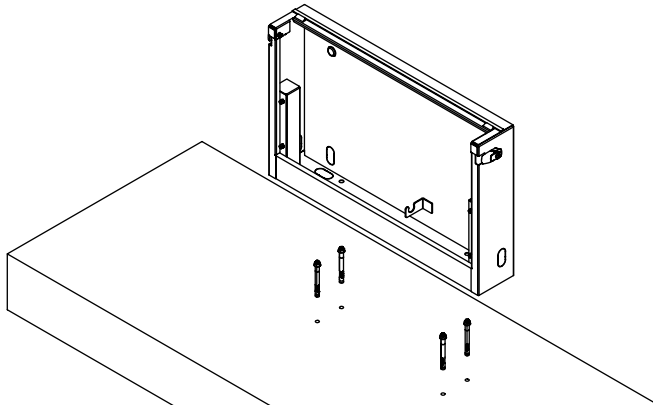

Post Mounted Installation

Where a concrete slab is not available for installation, the included mounting posts can be used to install the system in a garden bed (or similar).

9. Before you start digging, call your utilities/service providers to make sure that there aren't any pipes/lines where you'll be digging.
10. Ensure there is adequate room for the enclosure once installed.
11. Dig two fence post holes approximately 810 mm centre distance apart. Ensuring the holes are at least 600 mm deep and 150 mm in diameter.
12. Lay the system on its back and slide the mounting posts into the openings at the bottom of the unit until they cannot be pushed up any further.
13. With the cover removed, install the 4 supplied grub screws into the channel supports inside the enclosure. And ensure the grub screws are tightened firmly. See Fig. for details
14. The bases of the posts can be optionally flared out for additional pullout retention.
15. Pack 50 mm worth of gravel into the base of the hole to provide some drainage for the post.

16. Mix up sufficient concrete (following manufacturers instructions) for both holes, and fill the holes with concrete.
17. Place the unit atop the holes, ensuring the mounting posts are submerged into the concrete and the unit bottoms out.
18. Support the unit in place as the concrete sets, ensuring the unit is level in both horizontal and vertical orientations.
19. Ensure the concrete has set before proceeding to step 23 of the installation.

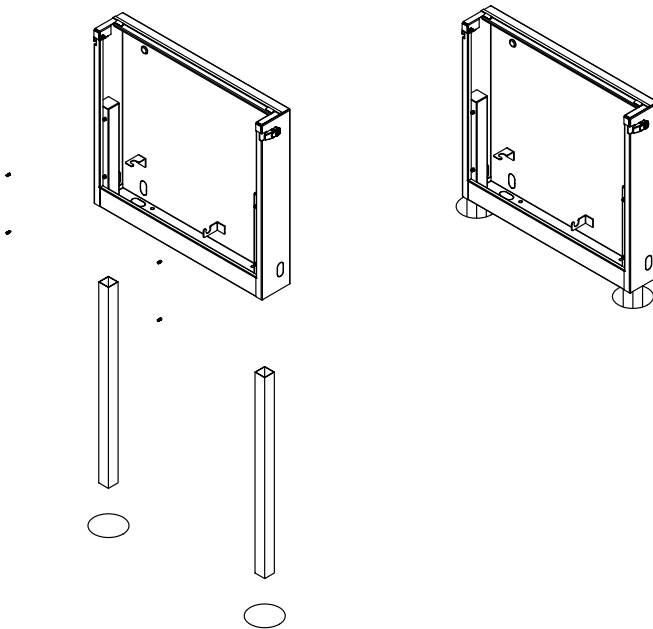

Wall Mounted Installation

As the system hasn't been provisioned for wall mounting, should there be a desire to do so, the unit can have holes drilled into the rear of the enclosure.

20. Drill four holes that are 8.3 mm in diameter into the rear of the enclosure, one in each corner approximately 30 mm away from the edges. Ensure the holes are not located on the knockout tab at the bottom of the unit and are clear of any internal features.
21. Matching holes can then be drilled into the wall that line up with the holes installed into the enclosure.
22. Using appropriate wall mounting hardware (not supplied) mount the unit to the wall.

23. With the enclosure securely mounted, the desired inlet and outlet knockout tabs can be removed (if not already done). Whilst wearing gloves, using a screwdriver and a mallet, firmly hit the knockout to dislodge the knockout panel. The burrs can be appropriately filed smooth.
24. Use approved 20 mm (Copper, PEX or other suitable) fittings to connect to the mains water inlet line to the system inlet.
25. Use approved 20 mm (Copper, PEX or other suitable) fittings to connect to the treated mains water line on the system outlet.
Note: The outlet tee fitting can be rotated to better suit a downwards outlet if desired, by removing the connected female flexible hose connections and rotated such that the outlet faces downward.
26. Ensure free operation of the inlet, outlet and bypass assembly ball valves by rotating the valve handles between OPEN and CLOSE 2-3 times. Ensure all 3 are left in the OPEN position.
27. Once the unit is secure and plumbing completed, re-install the cartridges and housing bowls. Hold the bowls upright while screwing in the housings. Make certain that the spigot in the housing heads is located centrally to the cartridges to make a good seal. Use the provided spanner to tighten each filter bowl until firm. **DO NOT OVER TIGHTEN.**
28. With a downstream tap open, turn on the water supply to purge air from the system.
29. Once purged, turn the bypass shut off valve to the CLOSE position, then turn off the downstream tap.
30. Inspect the system connections for leaks. Be sure to check all the connections including the bypass assembly. Retighten any joints as required and retest.
31. Reinstall the cover by engaging the bottom of the cover with the bottom edge in the housing. This edge can then be used to pivot the cover upwards and closed. The cover will meet some resistance as it engages at the top. The latches can then be closed and locked if desired.

Warranty

Any claim under this warranty must be made within 10 years of the date of purchase of the product. This product is warranted to be free of defect of material and workmanship for 10 years from date of purchase.

Puretec is renowned for its quality and after-sales support so if you have any issues please call 1300 140 140 (AU) or 0800 130 140 (NZ). To make a warranty claim, contact us directly or the place of original purchase. All costs relating to a warranty claim must be approved by Puretec prior to any work being carried out.

10 year warranty is 1 year parts and labour plus 9 years parts only. Excludes cartridges. Puretec will pay your reasonable, direct expenses of claiming under this warranty. You may submit details and proof of your expense claim to place of purchase for consideration.

The warranty only applies if the product was used and/or installed in accordance with the user guide and/or installation instructions. This warranty is given in lieu of all other express or implied warranties and manufacturer shall in no circumstance be held liable for damages consequential or otherwise or delays caused or faulty manufacturing except as excluded by law.

Applicable to all above, is that the warranties need to be approved by Puretec to ensure product was not incorrectly used, installed or claimed. False and incorrect claims will be pursued at Puretec's discretion, including chargeable inspection and labour costs incurred.

Warranty/Australia

This warranty is given by Puretec Pty Ltd, ABN 44 164 806 688, 37-43 Brodie Road, Lonsdale SA 5160, telephone no. 1300 140 140 and email at sales@puretec.com.au.

This warranty is provided in addition to other rights and remedies you have under law: Our goods come with guarantees which cannot be excluded under the Australian Consumer Law. You are entitled to replacement or refund for a major failure and to compensation for other reasonably foreseeable loss or damage. You are also entitled to have the goods repaired or replaced if the goods fail to be of acceptable quality and the failure does not amount to a major failure.

Warranty/New Zealand

This warranty is given by Puretec NZ LP, Reg. No 50081773, PO Box 875 Cambridge 3450 NZ, telephone no. 0800 130 140 and email at sales@puretec.co.nz.

This warranty is provided in addition to other rights and remedies you have under law: Our goods come with guarantees which cannot be excluded under the Consumer Guarantees Act. You are entitled to replacement or refund for a major failure and to compensation for other reasonably foreseeable loss or damage. You are also entitled to have the goods repaired or replaced if the goods fail to be of acceptable quality and the failure does not amount to a major failure.

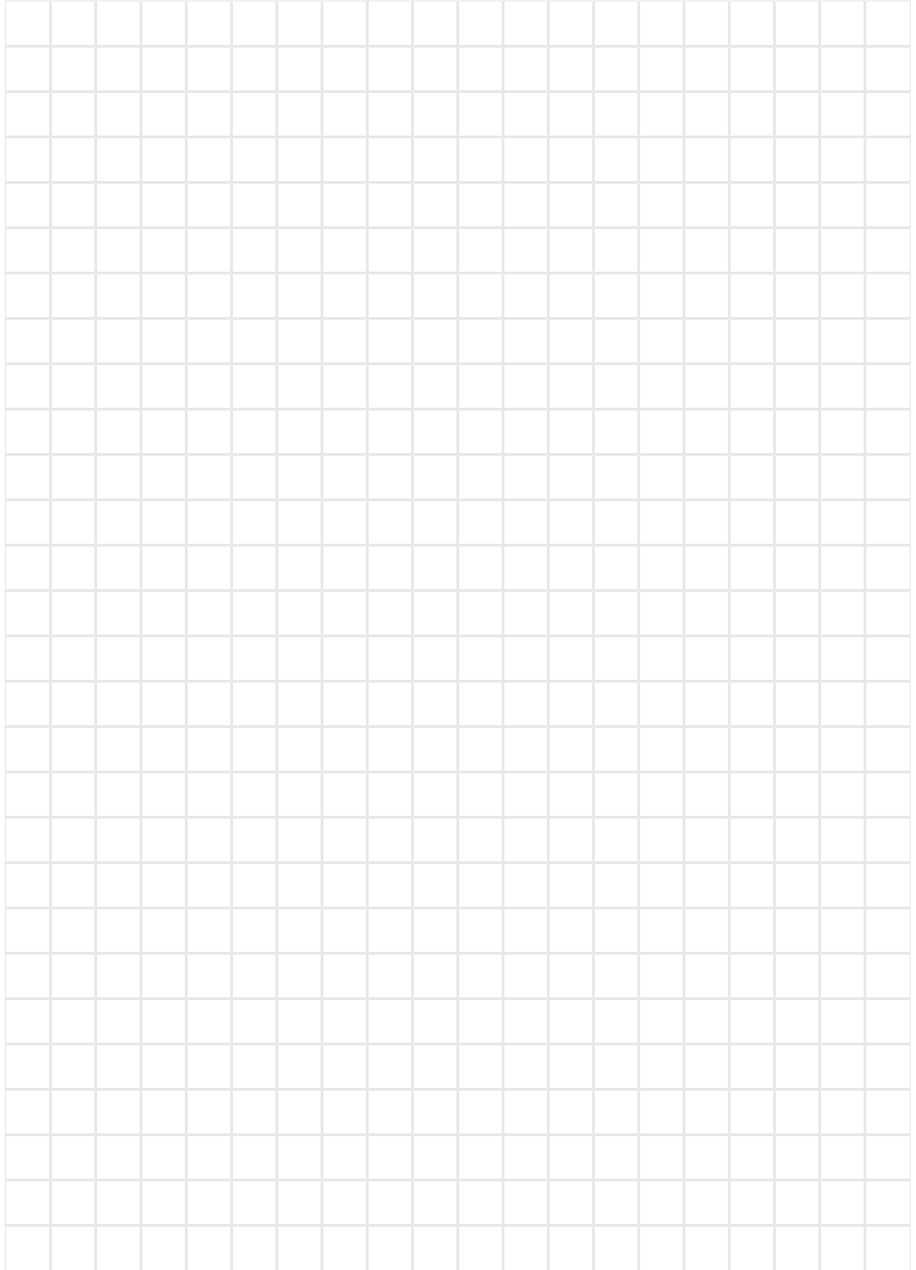

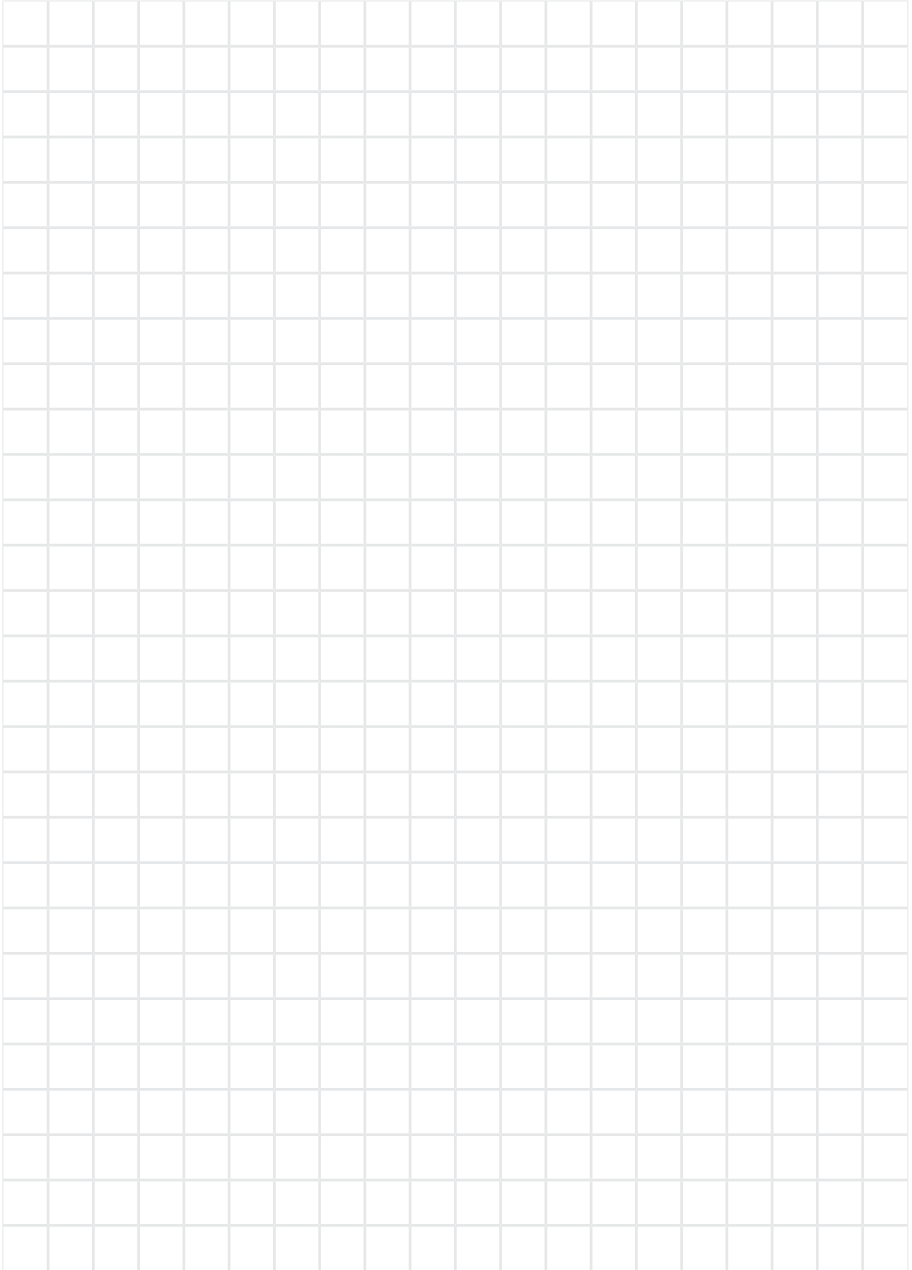





AUSTRALIA

P 1300 140 140
E sales@puretec.com.au
W puretec.com.au

NEW ZEALAND

P 0800 130 140
E sales@puretec.co.nz
W puretec.co.nz