

Prolam® PLX Portal

Installation Guide



**Building
better
together**



Prolam®
Engineered Laminated Timber

Easy on-site assembly

Assembly Overview

"L" brackets to be installed with 3mm nails to column before any other parts

Ensure these faces are flush to each other, release nut tension if adjustment is required

Slide sprung plate over threaded rods ensuring that the centre of the plate touches column first, not the ends

Tighten nuts until both belleville washers and sprung plate are flattened

Install belleville washers so that inside of cone faces spring plate

Refer to detail A on page 12 for cutting limits

Install the base bracket with 10 VGS 9x200 screws

Install VGS 9x160 keeper screws

Insert lower rod through column first and connect both arrow dovetail sections together

This rebate to be fully seated on to the "L" bracket

Install VGZ 2/7x200 screws

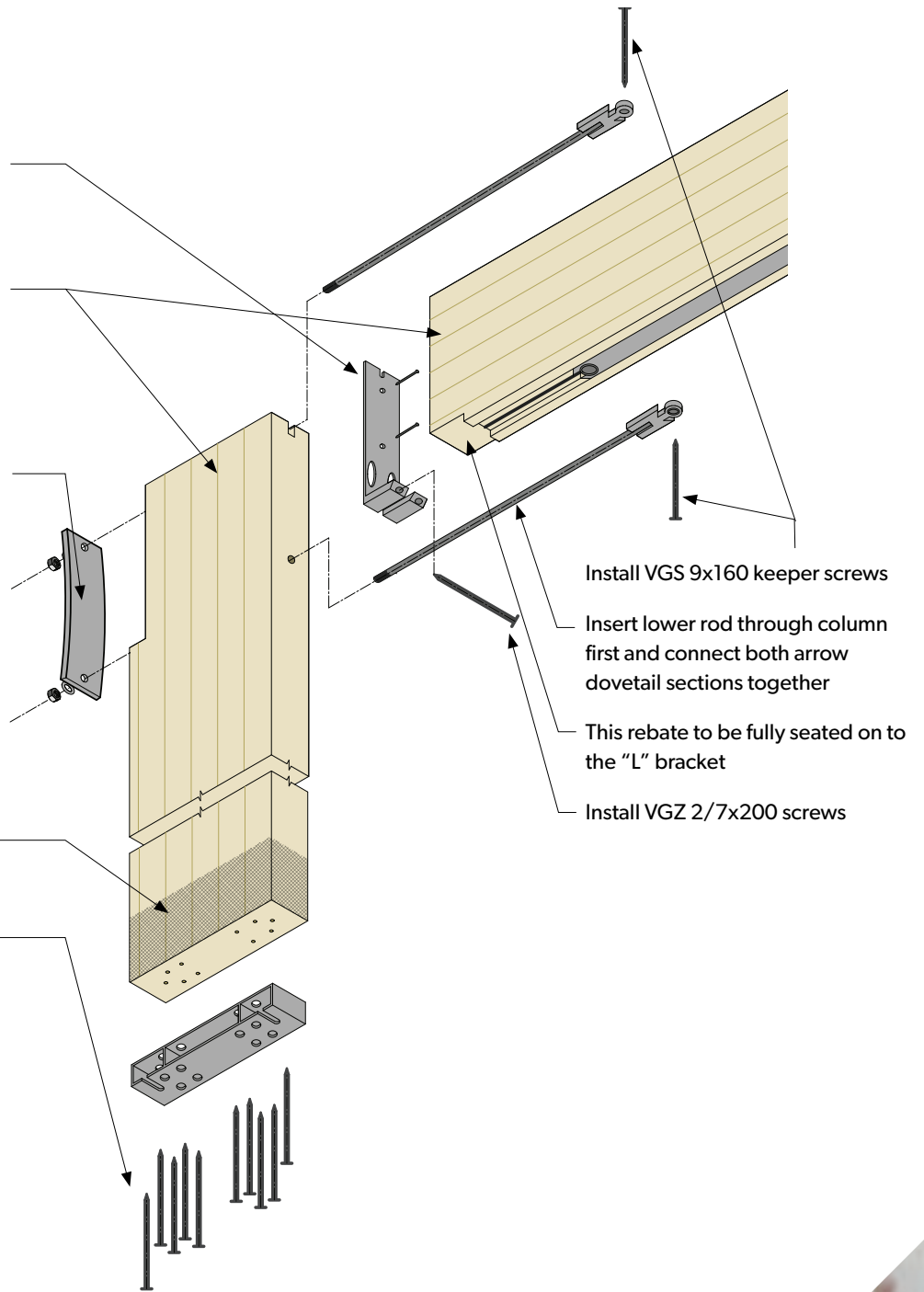

Assembled

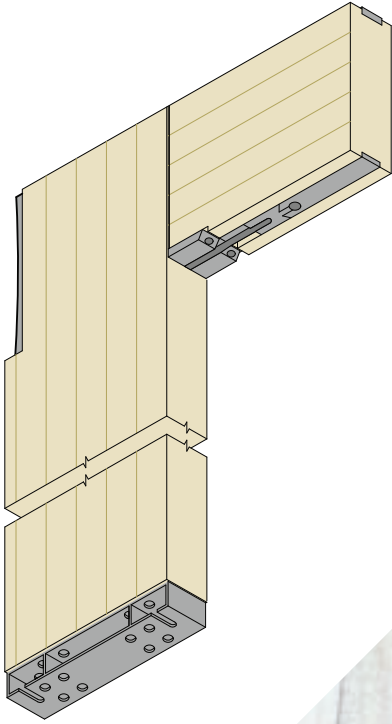

Strong, lightweight
and simple to install

Construct the PLX Portal system in the following sequence:

1. Determine the inside dimensions of the portal opening height and width.
2. Cut the lintel equally at each end to the desired length, to a maximum of 150mm from the lintel 40x10 steel. Allow for the 5mm steel "L" bracket. Don't cut the steel in the PLX20 lintel!
3. Cut the portal legs (from the bottom of the column, not the top) to the desired length. Allow for the height of the portal leg bracket (50mm). Refer to PLXP-4 on page 6
4. Install the base plate brackets using 10 VSG 9x200 screws per base plate (6mm pilot hole), slot orientation towards the inside of the building to achieve 50mm hold down fastener edge distance (For concrete slabs). Refer to photo on page 6
5. Install the hold down bolts for concrete, or M12 threaded rods for timber sub floors. Refer PLXP-2 and PLXP-3 on page 5 for fixing details



Concrete Floor Connections

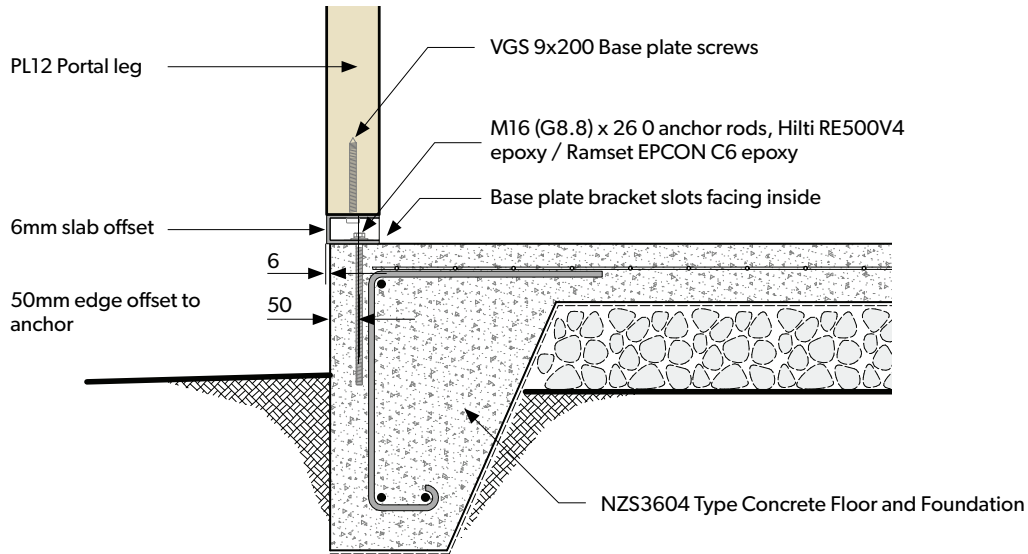

PLXP-5
2023-06-19

Timber Floor Connections

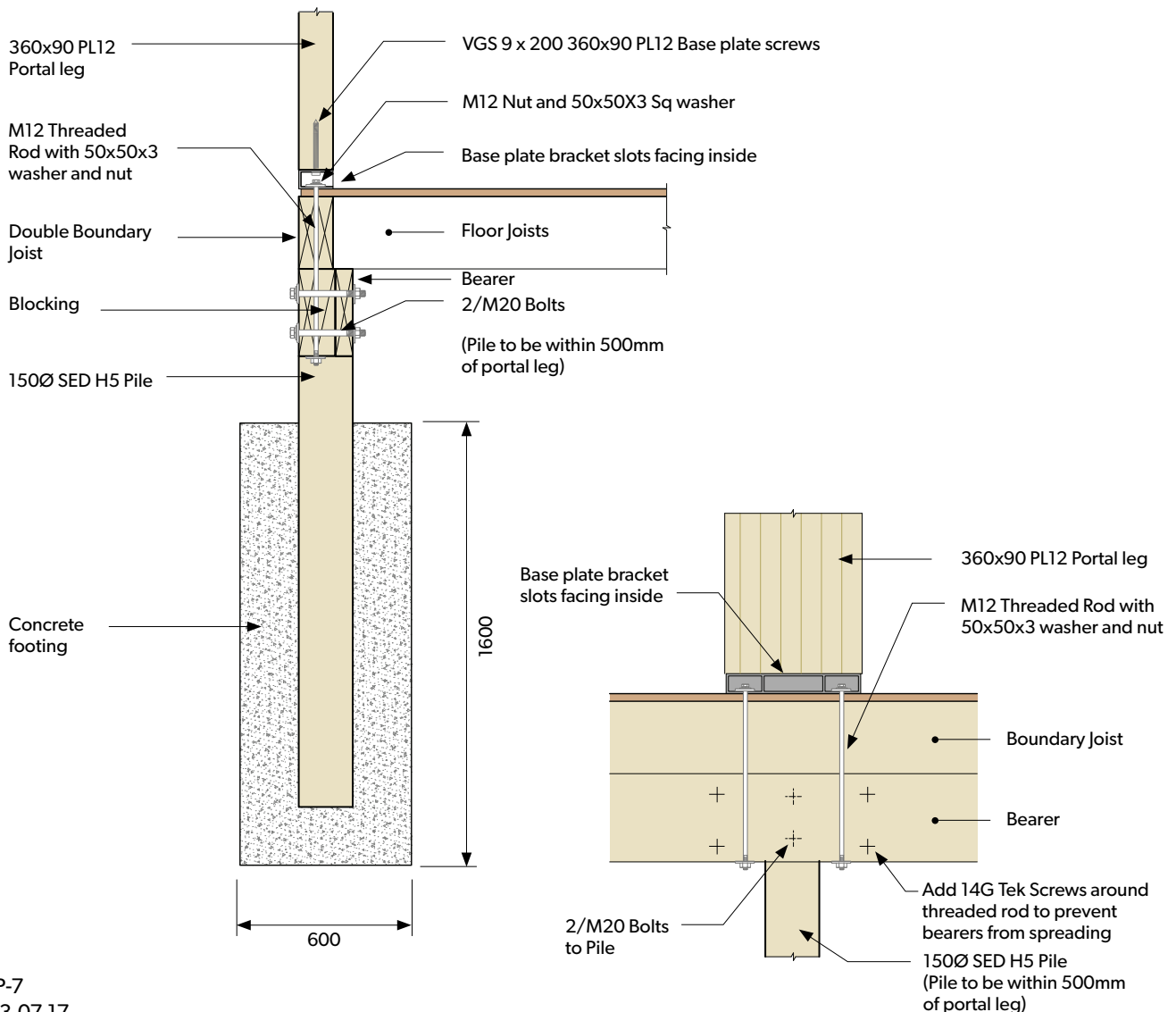

PLXP-7
2023-07-17

Detail A

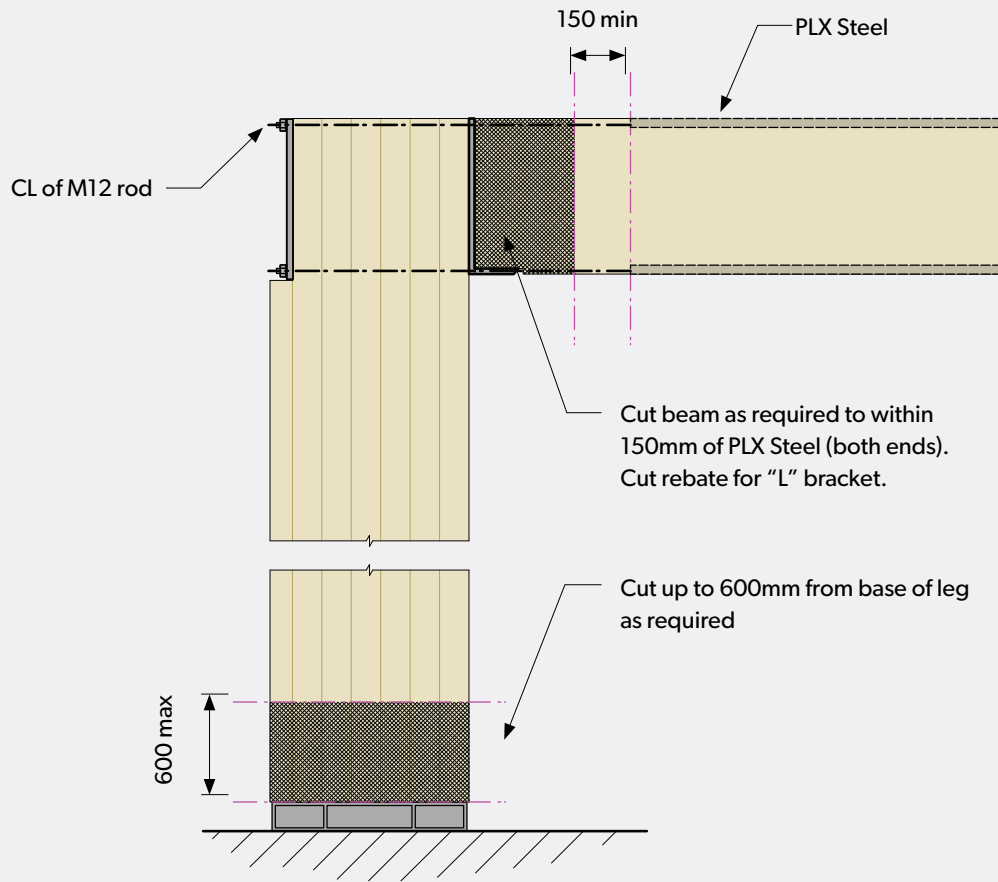

PLXP-8
2023-06-19

3



4

Option 1. Stand up portal legs first then install PLX20 lintel.

1. Stand the portal legs up, brace, then tighten the hold down bolts. Using the 50x50x3 washers.
2. In both portal legs, install the bottom M12 threaded rod assembly, through the 12mm backing plate (curved ends facing out) and using the Belleville washers between the nut and 12mm backing plate, and nail the L bracket on the lintel side of the portal leg into place.
3. Drop the PLX20 lintel (pre camber facing up) into place.

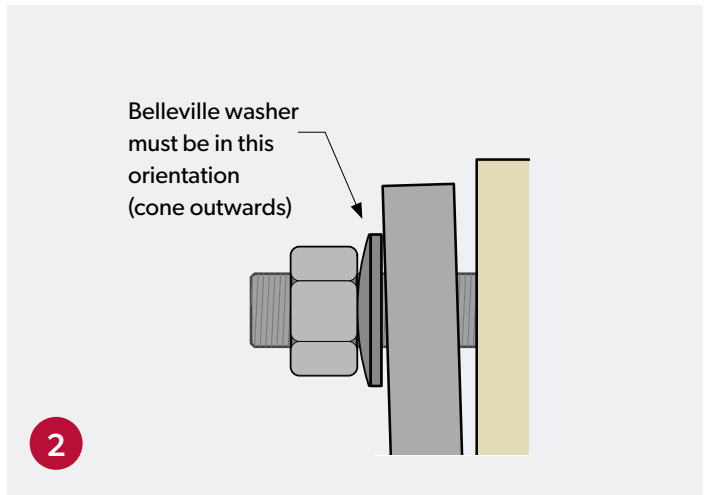

Option 1 continued.

4. Add the top M12 Threaded rod assembly.
5. Screw the top and bottom arrow head connectors into the PLX20 lintel using VGS 9x160 screws.
6. Square and level the portal structure.
7. Install backing plate with curve facing out, install Belleville washers (cone facing out) and tighten to 50Nm torque to flatten both the Belleville washer and the plate against the timber leg.
8. Add the VGZ 7 x 200 uplift screws at 45degrees through the L bracket into the Lintel then into the leg.

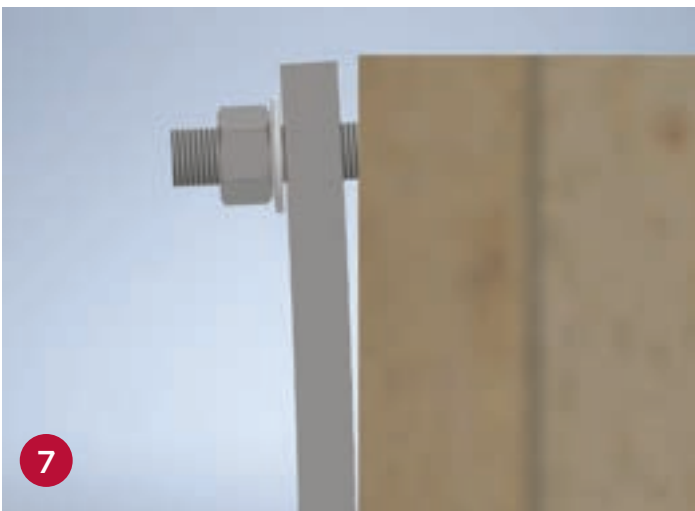

Option 2. Build portal on the ground and stand up into place. (Complete instructions 1-5 first).

1. Lay the portal legs and PLX20 lintel (pre camber facing up) in place on the ground in position.
2. In both portal legs, install the bottom M12 threaded rod assembly, through the 12mm backing plate (curved ends facing out) and using the Belleville washers between the nut and 12mm backing plate, and nail the L bracket on the beam side of the column into place.
3. Screw the top and bottom arrow head connectors into the PLX20 beam using VGS 9x160 screws.
4. Tighten the M12 bolts to 50Nm torque and flatten the Belleville washer and 12mm backing plate flat against the portal leg.
5. Stand the entire portal into place, level, brace and tighten the hold down bolts using 50x50x3mm washers.
6. Square the lintel and portal legs then add the VGZ 7 x 200 uplift screws at 45 degrees through the L bracket into the lintel then into the portal leg.

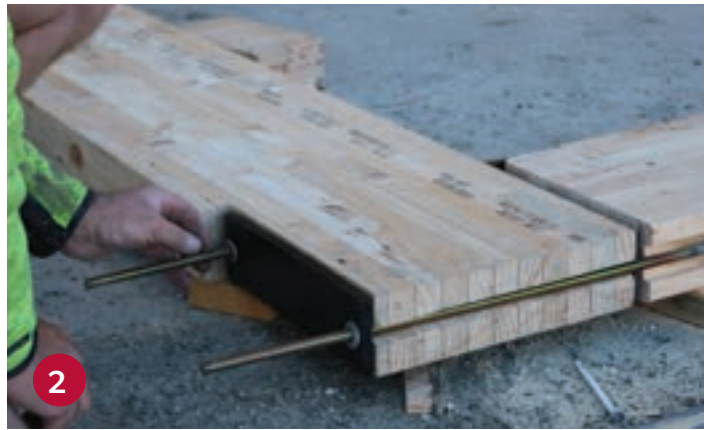

Building Better Together

At Prolam, we support architects and building professionals to design and build with strength, confidence and ease using premium engineered timber solutions.



NZ made quality

Innovative timber solutions designed and made in New Zealand using high quality, locally sourced materials – creating local employment and training opportunities

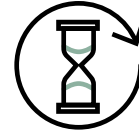

Fast and efficient

Industry-best lead times via a secure supply chain, proactive management of stock holdings and next level production efficiencies



Solid eco-credentials

Made from New Zealand plantation timber, with research-backed resistance to harsh environmental conditions

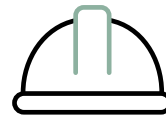

Strong and safe

Precision engineered for a superior fit, optimal structural integrity, dimensional stability, and easy and safe installation



Confident compliance

Prolam sets the benchmark in building code compliance and certification for glulam timber products – for smooth engineering and building consent approvals

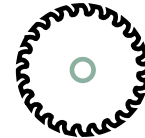

Cutting edge technology

Advanced manufacturing processes and smart tools that streamline product specification, supply, installation and certification



Built-in ease

Control at every step, with expert technical advice on tap – from knowledge of local industry codes, precise product specification to installation and after sales support



FSC Certified Manufacturer

Ask about our product range

The partner of choice and key support for specifiers, design and building professionals, and merchants seeking robust and compliant beams, posts and lintels for building projects of any kind and size.

Prolam®
Posts

Prolam®
PLX20

Prolam®
Beams

Prolam®
Crib Walls

Prolam®
Fascia

Prolam®
PLX Portal

A group of six construction professionals, including men and women, are gathered in a warehouse or construction site. They are wearing high-visibility safety vests in yellow and pink. One man in the foreground is holding a tablet or document, and the group appears to be in a discussion. The background shows stacks of lumber and wooden framing structures.

NZ made
quality

**Building
better
together**



Planning a project?
Our team of experts are ready to assist.

03 526 7436
info@prowoodnz.com
prolamnz.com

Building better together



Prolam[®]
Engineered Laminated Timber