

Project Sink

PS83TU NZ OF
3/4 & 1/2 Bowl Universal Sink

**MINIMUM
ORDER
QUANTITIES
APPLY**

All dimensions in mm

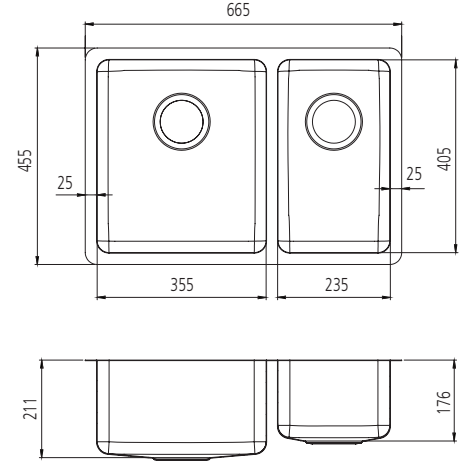

Specifications /

Sink size	665W x 455H x 210Dmm
Bowl size	3/4 Bowl 355W x 405H x 205D / 30L 1/2 Bowl 235W x 405H x 170D / 16L
Construction	Fabricated with 25 mm radius corners, Softtone® and soundproofing.
Material	304 grade, 18/10 brushed stainless steel (1.2 mm thick)
Installation	Topmount or undermount
Fixings	Installation clips supplied
Min cabinet size	900 mm
Tap holes	N/A
Waste fittings	2 x 90 mm basket wastes included
Overflow	Included
Carton size	840 x 510 x 250 mm
Weight	9 kg
Warranty	Lifetime manufacturer's warranty (refer to oliveri.co.nz)
Maintenance and care instructions	All surfaces should be cleaned with mild liquid detergent or soap and water. To maintain the shine on your Oliveri stainless steel sink, we recommended the use of any of the easy to obtain, non-abrasive stainless steel cleaners or metal polishes.

Included accessories /

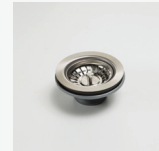
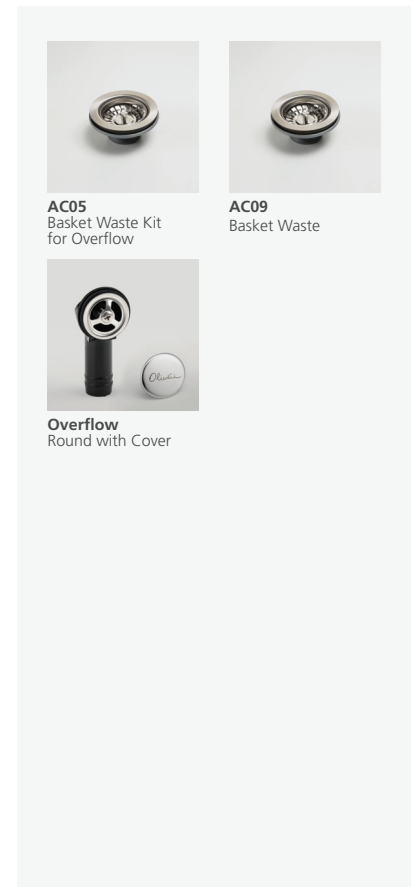

AC05
Basket Waste Kit
for Overflow



AC09
Basket Waste

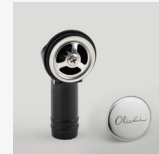

Overflow
Round with Cover