

STRATA

FLOORING

Waterproof SPC Technology

Premium Quality SPC
Flooring

OWNERS MANUAL

- Installation
- Maintenance
- Warranty

READ THIS MANUAL THOROUGHLY PRIOR TO
INSTALLATION

It contains important information for pre-
installation conditions, installation instructions
plus care & maintenance.

Simple Uniclic jointing
system makes installation
fast and easy!

Angle

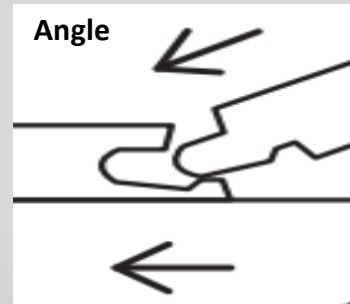

Drop

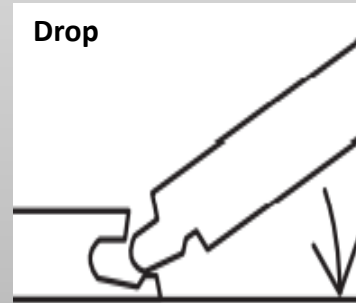

Lock

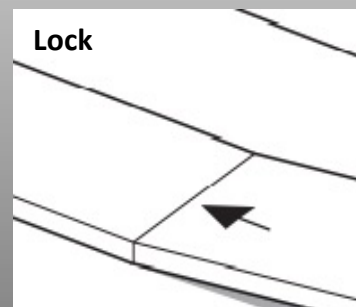

introduction

STRATA Sentry Sentry flooring combines simple Uniclic installation featuring innovative SPC Technology; a waterproof, strong and stable core that offers outstanding performance, durability and longevity. Planks have sound mitigating underlay pre-attached to help minimize sound travel.

The SPC Layer features a stone polymer core that is 100% waterproof, rigid and dimensionally stable. This means planks resist warping, expansion and contraction, and help hide subfloor imperfections.

STRATA Sentry Sentry is easy to install with simple Uniclic installation. The Uniclic side joining system means that planks can be angle joined or flat locked.

STRATA Sentry Sentry can be installed over some existing floors such as natural wood, concrete, vinyl, linoleum, and even ceramic tiles, saving you time and money! *(See subfloor preparation section on page 3.)*

STRATA Sentry is WATERPROOF, so it can be installed in areas that have been “off limits” for traditional plank flooring and laminate products, like laundries and bathrooms. STRATA Sentry is not meant to be a moisture barrier. It will not prevent damage from flooding, excessive moisture, alkalis or conditions from hydrostatic pressure in the subfloor. *(See subfloor preparation section on page 3.)*

Follow the instructions for installation in the next section and you will be enjoying your beautiful new floor in just a few hours.

installation instructions

Tools needed

- Utility knife & straight edge (Drop saw, skill saw etc. can also be used)
- Measuring tape
- Soft faced, rubber mallet or dead blow hammer
- Jig saw for cutting around irregular shaped objects (pipes)
- 8mm – 15mm spacers
- Pencil
- Tapping Block

Planks needed to complete your project

Measure the length & width of your room. If the room has alcoves or offsets, measure these separately. This will give you the square metre area of the room. Purchase a minimum of 10% extra to cover wastage, trimming and for future needs and/or replacement. Most installations require about 10% overage. However, this can vary depending upon the room size and layout.

HELPFUL HINT #1:

For best results, it is important to purchase product (cartons) from the same batch # (dye lot) whenever possible. Always install planks from 3 or 4 cartons at one time. Different batch #'s can have shade variations. Every carton of STRATA Sentry has the batch # printed on the ends of the cartons.

If you do have more than one batch # we recommend you install planks from 3 or 4 different cases from different batch #'s at one time and randomly mix them into the installation as you go. This will ensure a more natural looking floor.

installation limitations:

Do not install STRATA Sentry flooring over carpet. Do not install STRATA Sentry over a separate underlayment. STRATA Sentry is not suitable for any outside use, sunrooms/solariums, saunas, seasonal porches, camping trailers, boats, RV's or rooms that have the potential for flooding. Exposure to long term direct sunlight can cause damage to your floor. Failure to properly shade or UV tint windows can discolour, fade, peak or buckle STRATA Sentry. Use window treatments or UV tinting on windows. Do not glue, nail, screw or fasten to substrate. Install cabinetry, island and peninsula counters, vanities, tubs, and showers first. Then install STRATA Sentry around them. For more information on installation specifications please see the chart on right. **Failure to follow these guidelines will void the warranty.**

Condition STRATA Sentry Flooring to the environment **prior to installation.** The installation of STRATA Sentry flooring does require acclimatisation. We recommend installation in rooms with temperatures between 13°C & 32°C. Product should be stored horizontally in a dry area away from direct sunlight. Do not leave next to heat or cooling ducts. Ensure that all trades have been completed to eliminate dry wall dust, paints, etc.

NOTE: If STRATA Sentry Flooring is subjected to extreme hot or cold temperatures prior to installation, it may make the product more difficult to install or cause damage to the locking system. Allow the product to reach room temperature before installation.

STRATA Sentry FLOORING INSTALLATION TECHNICAL DETAILS	
Connection type	Uniclic
Free Floating Floor	Yes. DO NOT screw or nail mouldings, transitions, cabinetry or vents through ANY STRATA Sentry flooring.
Temp. range before, during and after installation	13 deg C to 32 deg C. After installation temps should stay between 10 deg C to 35 deg C
For wider temperature ranges	Allow a min of 15mm for expansion gaps
Interior Product Only	Yes. See limitations/exclusions below.
Max room size	10m x 10m. Greater than this an expansion break must be installed. Expansion breaks must also be used in doorways less than 121cm wide.
Dye Lots	Yes. Install from a minimum of 3 to 4 different boxes and dye lots at one time. See page 2 for more information
Expansion Space	Yes. For room perimeters and fixed objects, please leave 8mm optimum space Leave 15mm where floor will receive direct sunlight
Floor Flatness Tolerances	3mm over 2.00m. Use floor leveller when exceeding tolerance
Special tools required?	Yes. Cutting tool such as Utility knife, drop saw or skill saw and straight edge, measuring tape, soft faced or rubber mallet (to tap and lock plank seams), Jig saw, tapping block, pencil and 8mm spacers
Moisture Reading Guidelines OVER CONCRETE Scale 0% to 4% Scale 5% to 6% Scale over 6%	Based on Tramex Concrete Moisture Encounter Plus Meter (scale 0 to 6%) No moisture barrier Use 150-micron poly moisture barrier Seal concrete with waterproofing agent
Moisture Reading Guidelines OVER WOOD Scale 0 to 13%	Never use 6mm poly. over wooden subfloors Ok to install. Do not install above 13% moisture levels
Primer Over Wooden Subfloors	No
Moisture Barrier (6 mm poly.)	Yes, above 5% only
Installs over Radiant Flooring	Yes. Electric or hydronic approved – best practice recessed min 12.7mm below finished floor. Do not turn thermostat above 30 deg C
Suspended Wood Floors	Yes. 457mm minimum well ventilated crawl space Use moisture barrier over ground/dirt Especially for mobile home installations
Carpet Underlay	No. Voids warranty if used in any application
Approved subfloors. See below	Must be smooth, solid, dry and no deflection
Wood	Yes. Solid, engineered, parquet, but not woods installed over concrete
Plywood	Yes. OSB & particleboard and approved construction grade plywood is approved.
Vinyl	Yes. Install over 1 layer only. Vinyl, linoleum, VCT, LVT, and Peel and Stick.
Concrete	Yes. Sealed, unsealed, poured in place. On grade or below grade (see moisture guidelines)
Plank (Stone)	Yes. Ceramic, Terrazzo, stone plank (grout lines of less than 3mm is optimum)
Subfloors Not Approved	Carpet (any type), cushioned back vinyl, rubber, cork, laminates, free floating floors
Limitations/Exclusions	These types of installations will NOT be covered under warranty. All exterior installations & seasonal porches, boats/campers/RVs, sunrooms/solariums, not-temperature controlled rooms or homes
Steam Cleaner	DO NOT USE
Vertical Surfaces & Staircases	Can be done using high quality construction adhesive. Product not intended for this usage
Limited Warranties	25 year residential. 7 year commercial.

Before installation, carefully inspect each plank for visual defects, damage, and sheen under adequate lighting (daylight is best). Do NOT install damaged or defective material.

1. Lay a row of loose planks (Figure 1) without securing them to each other first to determine if you need to adjust the length of the first plank to avoid a small piece of less than 20 cm on the opposite wall from where you started.
Or, measure the length of the room and divide by the length of one plank.
2. Installation should start in a corner (left hand) and proceed from the wall with the tongue facing the wall. Allow a minimum gap of 8mm for product expansion, which should be covered by a moulding (Figure 2). Set 8mm spacers to create the required expansion space.
3. When laying the first row in a straight line, interlock the short ends by inserting the tongue into the grooves at an angle of approx. 10 to 20 degrees (Figure 3). Install each sequential plank on the short end and be sure to line up evenly. Use a soft faced hammer to lightly tap down on top of the planks on the short seam to ensure a tight fit (Figure 7). This is very important for a good installation. When cutting STRATA Sentry planks use a utility knife, Jig saw or skill saw and a straight edge. Measure the plank for desired length and mark with a pencil. Then score with a utility knife on top of the plank first (several passes) and then snap the plank or cut clean through using a jig or skill saw.
4. When installing STRATA Sentry, stagger the rows so that the short edge seams are not in a straight uniform line. We recommend the staggered random method (Figure 4). Maintain a minimum 20 cm end-joint stagger from row-to-row throughout the entire installation.

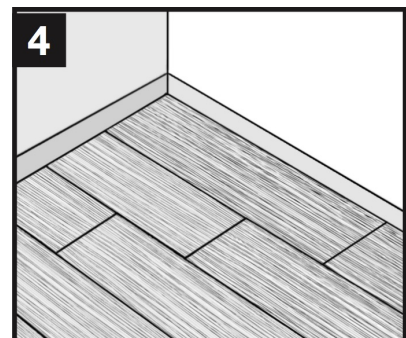
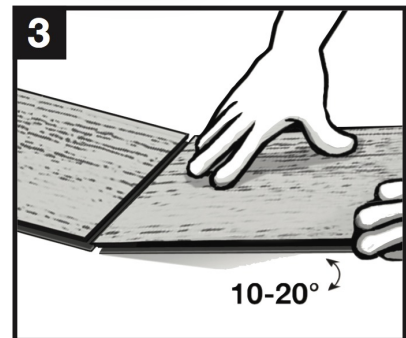
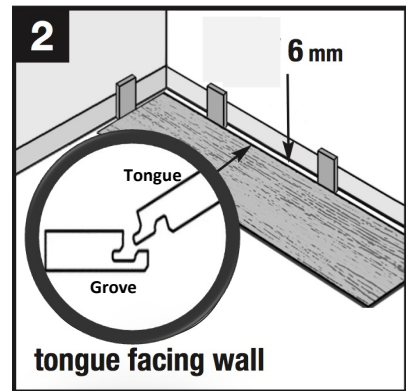
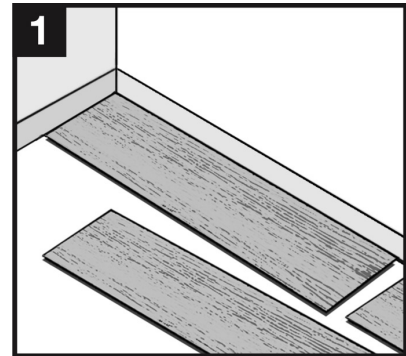

KEY INSTALLATION TIPS	
Interior environmental conditions	13°C to 32°C & 40% to 60% relative humidity
Acclimatisation for residential use	48 hours between 13°C & 32°C.
Acclimatisation for commercial use	48 hours between 13°C & 32°C.
Subfloor flatness tolerances	3 mm over 2 metres or 2 mm over 1 metre
Vapour barrier	Not required
Water proofing or tanking	Not required when Woodland Lifestyle E3 alternative solution is used. Wet area installation instructions must be followed – See www.woodlandlifestyle.com for wet area instructions.
Underlay	Not Required.
Radiant heated floors	Must be cast 12.7mm below subfloor. No electric mats.
Perimeter expansion	Min. 8 mm gap around walls and heavy fixed objects such as cabinetry. 15mm in areas of direct sunlight
Glue down installation	Not recommended – voids warranty.

STRATA

HELPFUL HINT #2:

For those who are not intimidated by power tools, or if you're a professional installer, you can also use a circular saw with carbide-tipped blade to make straight cuts and a Jig saw when cutting corners. If you use a power tool, be sure to wear safety glasses and dust mask and work in a well ventilated area outside the room of installation. Be sure all debris from cutting is removed from all locking mechanisms before installing.

5. Start the second row with the plank cut at 2/3 of the length or cut to desired length for desired staggered appearance (cut plank should be no less than 20 cm). Attach the first plank of Row 2 by connecting the long side to the first row. Maintain your 8 mm expansion gap. Then attach the second plank by connecting the long side to the first row and sliding it up to the short end of the first plank. Then tap the short ends together. See Figure 5. To ensure a tight fit, use a tapping block and soft faced hammer on the long seams (Figure 6). This installation method can also be done in reverse by angle locking the short ends first and then locking the long seams together (Figure 6).

HELPFUL HINT #3:

If you don't have a tapping block, you can use a small scrap piece of the SPC plank material (approximately 150 mm) as a tapping block.

6. When cutting a plank to start a row, you will need to cut off the end with the groove. The remaining piece can then be used on the opposite side of the room, at the end of the row if layout permits. See Figure 8. For a close-up of the end joint locking mechanism see Figure 2.
7. Fitting around irregular objects is no problem. Simply make a pattern out of heavy paper to fit around pipes or irregular objects. Place the pattern upon the plank and trace. Cut along trace lines using a Jig saw and lay the plank. Be sure to leave a minimum of 8 mm expansion space around all fixed objects, cabinetry, and metal door jambs. Undercut wooden door jambs. Fill any expansion spaces around potentially wet areas such as refrigerators, tubs, and appliances with premium waterproof 100% flexible silicone.

NOTE: Rooms larger than 100 m² (10 m x 10 m) require the use of expansion gaps or T-moulding transitions. Doorways and archways less than 121cm wide also require expansion gaps or T-moulding transitions.

HELPFUL HINT #4:

Save any leftover planks. Do not discard as they are colour matched (dye-lot) to your floor. They can be used in the event you need to replace a plank in the future.

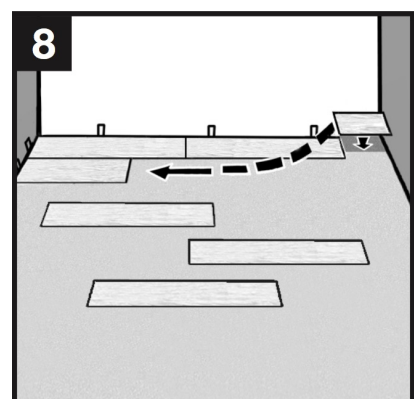
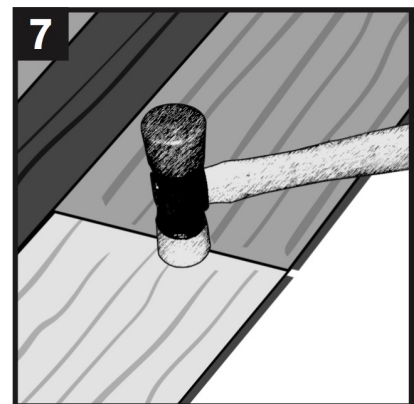
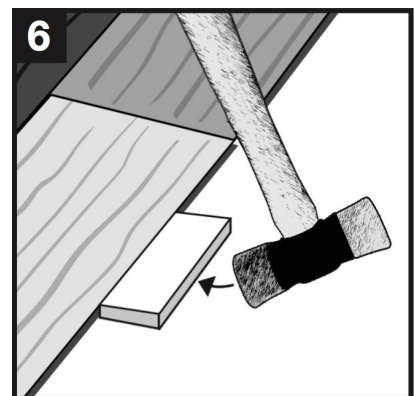
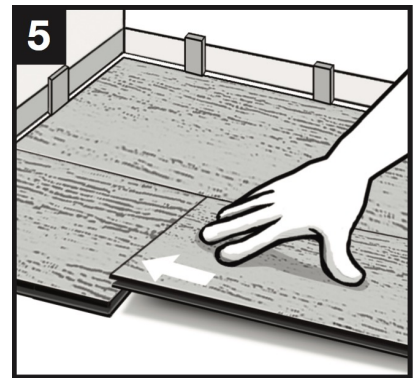

care & maintenance

Routine Maintenance

- Sweep, dust mop, or vacuum (with hard surface attachment) your floor on a regular basis. Never use a steam mop, steam cleaner or a vacuum with a beater bar.
- Use any ph-neutral good quality vinyl cleaner or a non-rinsing, biodegradable cleaner that leaves no residue or haze and requires no rinsing after application.
- Remove any standing water, spills, wine, pet urine and other liquids promptly.

Preventive Maintenance

- Use NON-RUBBER backed mats at all entrances to avoid discolouration from asphalt driveways or prevent dirt and grit from being tracked onto your floor. Rubber backed mats can discolour your floor.
- Use flat floor protectors (nylon or felt) on all furniture legs. Clean protectors periodically to remove grit that may become embedded and cause scratching.
- Do NOT drag or slide heavy furniture or objects across your floor to avoid scuffing and scratching.
- Do NOT use any dust cleaner or polish as this may cause your floor to become slick or damage the finish.
- Do NOT use a steam cleaner of any kind.
- Do NOT use any abrasive cleaner, vinegar, oil soaps, harsh detergents, "mop & shine" products or wax (wax will not penetrate STRATA Sentry and will discolour your floor.)
- Avoid spills of paints, dyes, or harsh chemicals.
- Clip pet nails. Pets with unclipped nails may scratch your floor.
- Avoid long term exposure to direct sunlight. Use window treatments or UV tinting on windows. (See installation limitations pg. 3)
- For office chairs and rolling furniture, use broad surface non-staining casters at least 50mm in diameter.
- Please note: failure to comply with care and maintenance instructions may void the warranty.

REMINDERS!

1. Retain your sales receipt.
2. Keep records of the style and batch number of your floor. This appears on the end of the carton along side the barcode.

STYLE of STRATA Sentry

Batch numbers:
