

## HPR10HT

Ritter Thermal High Temp HP, 10kW



### Technical Specification

Heating Capacity Range (kW): 5.4-14.95

Max Power Input (kW): 3.85

Max Current Input (Amps): 24.5

Max Output Temp: 75°C

COP 35-30°C @ 7°C: 4.53

COP 65-55°C @ 7°C: 2.32

COP 35-30°C @ 2°C: 4.22

COP 65-55°C @ 2°C: 2.02

Refrigerant: R290

Noise Ranged B(A): 43-57

Water Connection (Inch): 1

Water Flow Volume (m<sup>3</sup>/h): 1.7

Pump Pressure (m/H<sub>2</sub>O): 7.5

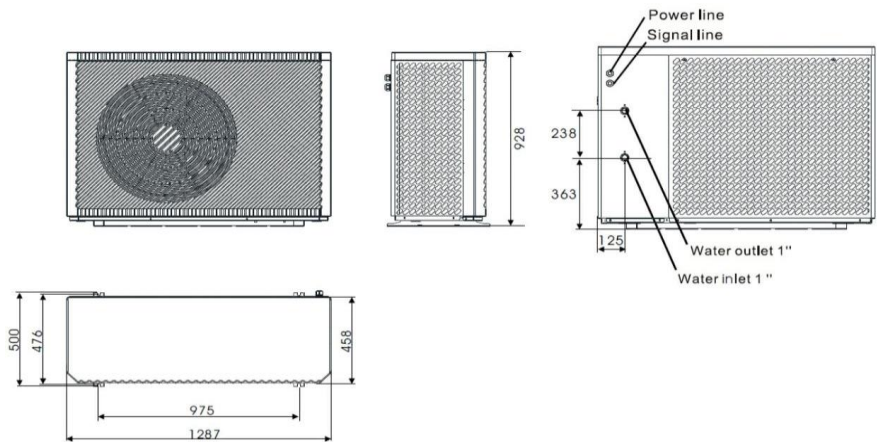

### Superseded Product

HPVP9

Vaillant aroTHERM+, 9kW

### Approvals

Comply with BS EN 14511-1-2013 Air to Water conditioners

### Warranty

5 years parts and labour

### Features

Ritter thermal is an inverter air to water heat pump with R290 refridgerant and high efficiency, optimized for underfloor, radiator & hot water applications. High quality and efficient compressor, fan and water pump is used to ensure the low noise level with insulation.

The heat pump is designed with galvanized sheet case with ASA grills

The PC microcomputer based controller is available for the users to review or set the running parameters of the heat pump with a smart phone and app control.

This series of heat pump is designed to work under different working conditions as low as -25 degrees for heating.