

Description	Product Code
Standard Switching	FAN7369

This Manrose inline extraction fan kit is designed for ventilation within a shower cubicle. The high performance fan provides high levels of extraction and enables additional ducting to be added to this system.

Thank you for purchasing this quality 150mm inline extraction fan kit.

To ensure correct function and safety, please read all instructions before using the product and keep all instructions for future reference.



When using electrical appliances, basic safety precautions should always be followed to reduce the risk of fire, electrical shock and personal injury.



SPECIFICATIONS

Duct (mm)	Fan Type	Max. Fan Watts (W)	Max. Fan Pressure (PA)	Free Air Fan Performance (l/s)	Interior Grille	Exterior Grille
150	Mixed Flow	60 70	240 300	92 166	Range Selection	Fixed Louvre White

Fascia Selections (sold separately)

Adapter Plate	Round				Square			
	White	Black	LED White	LED Black	White	Black	LED White	LED Black
	DCT4502	DCT4503	DCT4506	DCT4507	DCT4504	UC14505	DCT4508	UC14509



E6337 Compliance: AS/NZS60335-2.80:2016

Specifications are subject to change without notice

DIMENSIONS (mm)

Model	Cut-Out Size	A	B	C	D	E	F	G
Mixed Flow Fan	-	209	147	360	55	195	130	115
Adapter Plate	238	75	265	-	-	-	-	-
Round Fascia	-	272	-	-	-	-	-	-
Square Fascia	-	272	272	-	-	-	-	-

Note: Cut-out size is a nominal diameter for a circular cut-out.

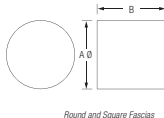
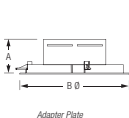
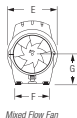
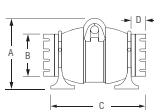

TECHNICAL

Supply	Motor Housing	Impeller & Outer Rotor	Ducting
220-240V AC, 50Hz	Die cast aluminium	PBT plastic	5m Flexible PVC

Installation Instructions

enquiry@manrose.co.nz | www.manrose.co.nz

Specifications are subject to change without notice

REGULATIONS AND STANDARDS

New Zealand Building Code and Healthy Homes

The following two category requirements have been established for mandatory extraction ventilation in New Zealand.

The New Zealand Building Code for New Building Consents

The building regulatory system sets out a framework to promote good quality decisions being made during the Building Consent process. The legislation and regulations work together, as the building regulatory system. The functional clauses of the NZ Building Code are grouped and described by a letter and number. Clause G of the NZ Building Code covers services, with G4 setting out the performance requirements for ventilation. The Building Code is enshrined in law. The New Zealand Building Code, G4, has been changed. This is supported by Acceptable Solution G4/AS1 Fourth Edition that specifies mechanical ventilation in accommodation units that contain cooktops, showers and baths.

Residential Tenancy Regulations to the Healthy Homes Standards

Residential Tenancy Regulations for rental properties only is changing to the Healthy Homes Standards, sub part 4 - Ventilation Standards.

Complying with the Acceptable Solution G4/AS1

To comply, the mandatory mechanical extract system must deliver minimum airflow rates for the complete installed ventilation system. This means that airflow rates must deliver the airflow after resistance of the ducting, internal and external grilles, as well as all other accessories, such as backdraught shutters, are included.

Fan selection is important as some types are far better at overcoming ducting system pressure drops.

Additionally, the quality of the ducting system installation can be all important. Rigid duct systems are best as they are the most efficient. Good installation practice is vital for flexible duct systems.

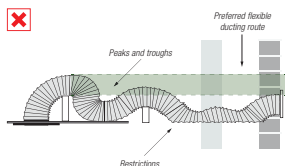
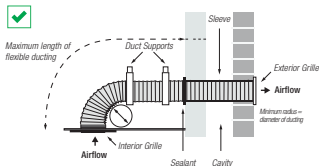

Choosing the Right Fan to Comply

Fans cannot be selected on the basis of free-air performance only. Fans must now be selected on the basis of the complete installed system performance for a bathroom as per the table below.

Room	Airflow Rate (min.)	
	Intermittent	Continuous
Toilet ¹⁾	25 l/s	10 l/s
Bathroom/Shower	25 l/s	10 l/s

¹⁾ Toilets only require ventilation if they have no operable windows

Recent unregulated extract fan practices in New Zealand has trended to basic, low pressure axial fan products, as installed system performance has not been defined for independent inspection testing and compliance signed off by local authorities.

Bathroom

25 l/s

		Metres of Ducting									
		1	2	3	4	5	6	7	8	9	10
No. of Bends	1										
	2										
	3										
	4										
	5										

Fan Selection

■ Mixed Flow



INLINE EXTRACTION FAN KIT INSTALLATION AND ELECTRICAL CONNECTION MUST BE CARRIED OUT BY A REGISTERED ELECTRICIAN



CAUTION

- Before use, please check that the supply voltage and that of the appliance are the same (see product rating label).
- All wiring and wiring connections must comply with all current national wiring rules and regulations including AS/NZS3000:2018, or latest edition thereof.
- Any changes or modifications made or attempted to this product, without the prior written approval of the manufacturer, will void any and all stated warranties.
- When fitting through an external wall, an external grille must be fitted at all times.
- Fan kits should only be installed by fixed wiring. A flexible cord should not be used.
- This fan is not intended for use by persons (including children) with reduced physical, sensory or mental capabilities, or lack of experience and knowledge, unless they are capable of, and have been given supervision or instruction concerning use of the appliance by a person responsible for their safety.
- Children should be supervised to ensure that they do not play with the fan.
- In case of damage to the supply cord, switch off the device and do not tamper with it. Damaged supply cords must only be repaired or replaced exclusively by the manufacturer or by an appointed representative. Failure to comply with the above may endanger the safety of people and cause possible damage to the whole system.
- The fan kit is to be installed so that the blades are more than 2.1m above the floor.
- Precautions must be taken to avoid the back-flow of gases into the room from the open flue of gas or other fuel-burning appliances when mounted in outside windows or walls.



BEFORE INSTALLING THE INLINE EXTRACTION FAN KIT, MAKE SURE YOU HAVE TURNED OFF THE MAIN ELECTRICITY SUPPLY. DO NOT TURN IT BACK ON UNTIL THE INLINE EXTRACTION FAN KIT IS FULLY INSTALLED AND READY TO USE.



ALL ELECTRICAL WORK MUST BE CARRIED OUT BY A REGISTERED ELECTRICIAN IN ACCORDANCE WITH THE LATEST WIRING RULES AS/NZS3000.

WARNING

- This inline extraction fan kit is hot when in use. To avoid burns, do not let bare skin touch hot surfaces. Keep combustible materials away from the fan kit and keep them away from the sides and rear.
- Do not use near or in the immediate vicinity of a bath or swimming pool or any wet areas.
- To protect against electric shock, do not immerse cord or plug in water or any other liquids.
- Do not insert or allow foreign objects to enter any ventilation openings, as this may cause an electric shock, fire or damage to the fan kit.
- Do not put fingers or foreign objects into the grille while in operation.
- Any changes or modifications made or attempted to this product, without the prior written approval of the manufacturer, will void any and all stated warranties.
- To prevent overheating of this fan kit, keep the air inlets and outlets clean and free of anything that may cause blockage. Check all inlets and outlets from time to time to ensure it is clear of any dirt or dust accumulation. **DO NOT COVER.**
- Do not use it in areas where gasoline, paint, or flammable liquids are used or stored.
- This product contains recyclable materials. Do not dispose of this product as unsorted council waste. Please contact your local council for the nearest collection point.

ELECTRICAL CONNECTIONS

2 Speed Control

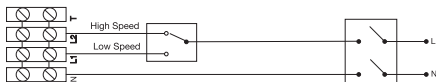

Low Speed Control Only

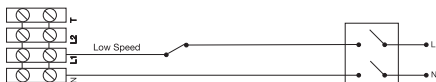

High Speed Control Only

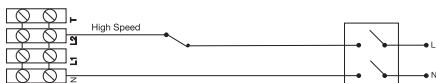

BEFORE INSTALLING THE MIXED FLOW FAN, MAKE SURE YOU HAVE TURNED OFF THE MAIN ELECTRICITY SUPPLY. DO NOT TURN IT BACK ON UNTIL THE MIXED FLOW FAN IS FULLY INSTALLED AND READY TO USE.

ALL ELECTRICAL WORK MUST BE CARRIED OUT BY A REGISTERED ELECTRICIAN IN ACCORDANCE WITH THE LATEST WIRING RULES AS/NZS3000.

INSTALLATION

1. First select the fascia you prefer in your room. There are eight designs in the Contour fascia range with the selection from white, or black, round and square fascias with, or without, an LED all suitable for fitting to the adapter plate supplied as part of this kit.
2. The **interior grille** comes in two parts, the adapter unit (supplied) and the fascia (sold separately). Cut a 238mm hole in the ceiling directly over the shower head ensuring first that the area above is free from obstruction and between two joists.
3. Push the adapter unit section into the hole in the ceiling and use the attached fixing clips to secure the adapter unit to the ceiling. Complete by fitting the fascia to the adapter plate by aligning the spring clips.
4. Select a suitable place for the fan to be screwed to a joist and secure using two screws through the fixing bracket. The fan motor is of ball bearing design to prolong the life of the motor.

NOTE: The suction end of the fan unit is the end where you can see the fan blade clearly. There is also an arrow on the unit showing airflow direction.

5. For the **exterior grille** select a suitable position in either the soffit or on an outside wall for the fixed louvre grille. Carefully remove the grille insert from its housing by levering gently at the sides with a small screwdriver. Cut a 160mm hole ensuring first that the area above is free from obstruction.
6. Attach one end of the flexible duct to the spigot with the duct tape provided and, from the outside, feed the duct through the hole until the grille is flush with the soffit/wall.

Mark the position of the fixing holes on the soffit/wall. Drill the holes and screw the grille to the soffit/wall then refit the chosen grille to the chassis.

NOTE: It is best not to cut the flexible duct until the grille has been screwed to the outside surface to avoid the possibility of cutting the duct too short.

7. Pull the flexible duct gently to the discharge spigot of the fan and cut it to length and connect to the fan with duct tape provided.

NOTE: The suction end of the fan unit is the end where you can see the fan blade clearly. There is also an arrow on the unit showing airflow direction.

8. Connect the remaining piece of duct to the ceiling grille and onto the fan using the duct tape provided.

NOTE: Make sure wherever possible to keep the duct running in a straight line as this will improve the performance of the fan.

9. Make the electrical connection as shown

NOTE: All wiring must be fixed securely and the cable to the fan should be a minimum of 1mm² in section in section. All wiring must comply with current regulations. This system should be installed by a registered electrician.

TYPICAL INSTALLATION

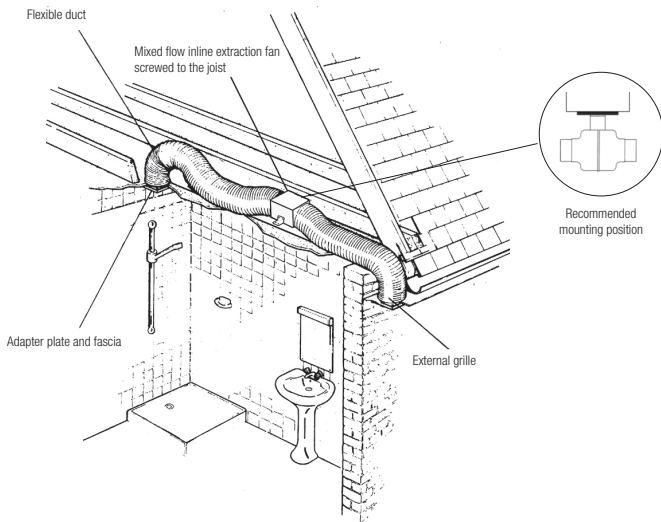

Simx Warranty Information

In this warranty:

We means Simx;

You means the consumer of the Goods

Supplier means the authorised distributor or retailer that sold you the Goods in New Zealand or Australia; and

Goods means the Simx product accompanied by this warranty and purchased in New Zealand or Australia.

The benefits provided to you under the following warranty are in addition to any other rights and remedies available to you under the law:

1. If, during the time from the date of purchase (Warranty Period), there is a defect in the Goods due to improper workmanship or material, we will replace or repair the Goods without charge. Any replacement product is warranted only for the time remaining on the original Warranty Period.
2. We are not obliged to replace or repair the Goods under clause 1 if the Goods have been improperly stored, installed, connected, used, operated, repaired, damaged, abused, tampered with, altered (without our written approval), or not maintained in accordance with our recommended installation, connection and operating instructions.
3. We exclude liability for:
 - a) consequential loss or any other loss or damage caused to property or persons arising from any cause whatsoever;
 - b) damage to consumable items such as lamps and starters; and
 - c) damage arising from normal wear and tear.
4. In order to claim under this warranty you must, within the Warranty Period, return the Goods to the Supplier, together with the original proof of purchase including the details below:

Supplier Name _____

Date of Purchase _____

Model Number _____

Invoice/Receipt No. _____

5. This warranty does not cover the cost of claiming under the warranty or transporting the Goods to and from the Supplier.

Our Goods come with guarantees that cannot be excluded under the New Zealand and Australian Consumer Law. You are entitled to a replacement or refund for a major failure and for compensation for any other reasonably foreseeable loss or damage. You are also entitled to have the Goods repaired or replaced if the Goods fail to be of acceptable quality and the failure does not amount to a major failure.

To speak to someone about your Simx product or claiming under this warranty, please contact:

Simx Ltd New Zealand

p: +64 9 259 1660 f: +64 9 259 1661

www.simx.co.nz