

# SPECIFICATION SHEET

## Venice Junior 500 Plus Wall Hung 2 Door Vanity



### Features

- Wall Hung
- 2 Doors
- StoneCast Interchangeable Basin
- Laminate Woodgrain & Solid Colours on MR Board
- Dimensions: H480 x W500 x D250

### Technical Details

Note: All measurements shown are in millimetres. Sizes are nominal.

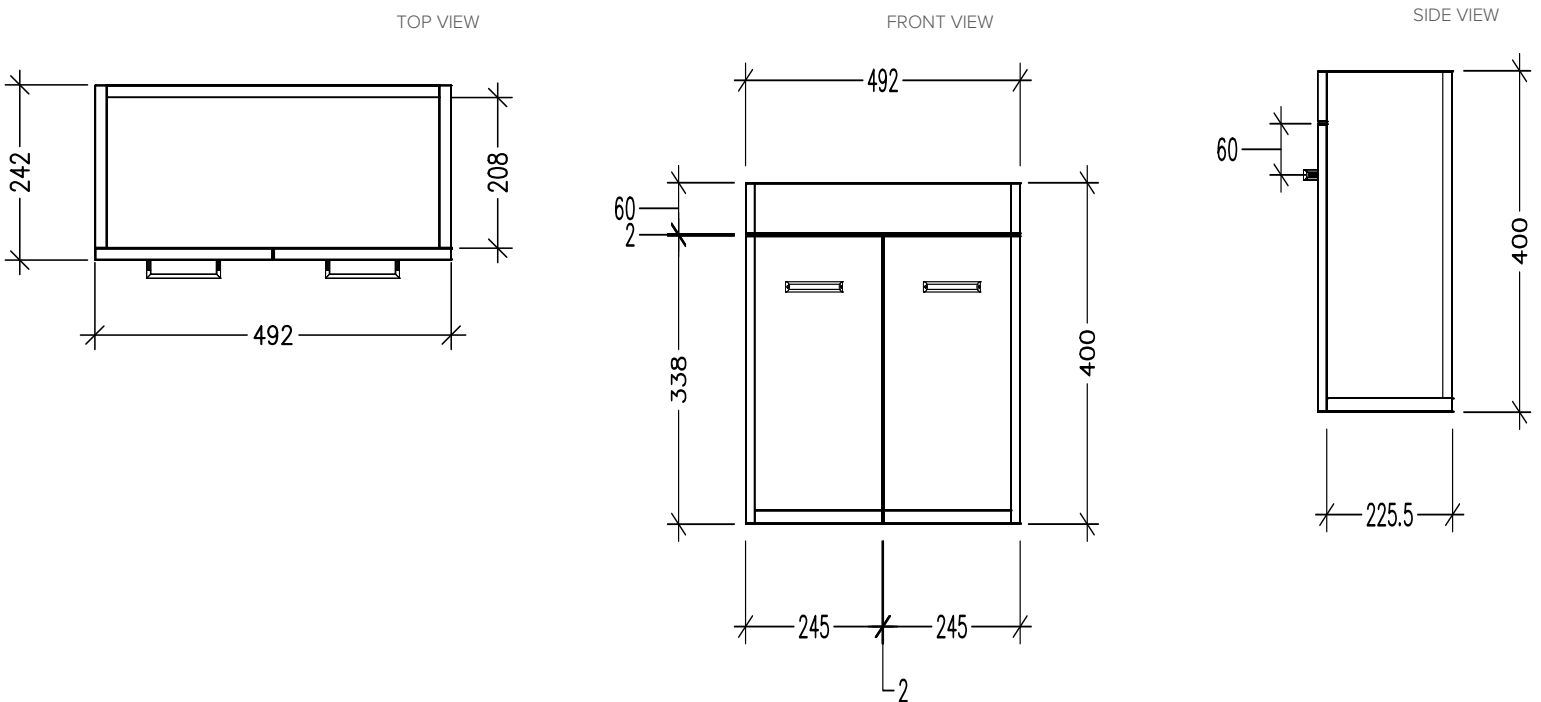

# SPECIFICATION SHEET

## Stonecast 500 Interchangeable Basin

StoneCast

PE500

W500(±5) x D250

