

INSTRUCTION MANUAL

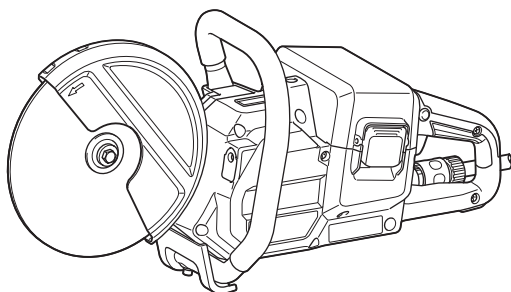

Cordless Power Cutter

DCE090



Read before use.

SPECIFICATIONS

Model:	DCE090
Wheel diameter	230 mm
Max. wheel thickness	3.0 mm
Max. cutting depth	88 mm
Rated speed	6,600 min ⁻¹
Rated voltage	D.C. 36 V
Max. permitted pressure of feed-water	5.0 bars
Overall length	554 mm
Net weight	5.6 - 6.3 kg

- Due to our continuing program of research and development, the specifications herein are subject to change without notice.
- Specifications may differ from country to country.
- The weight may differ depending on the attachment(s), including the battery cartridge. The lightest and heaviest combination, according to EPTA-Procedure 01/2014, are shown in the table.

Applicable battery cartridge and charger

Battery cartridge	BL1815N / BL1820 / BL1820B / BL1830 / BL1830B / BL1840 / BL1840B / BL1850 / BL1850B / BL1860B
Charger	DC18RC / DC18RD / DC18RE / DC18SD / DC18SE / DC18SF / DC18SH

- Some of the battery cartridges and chargers listed above may not be available depending on your region of residence.

⚠ WARNING: Only use the battery cartridges and chargers listed above. Use of any other battery cartridges and chargers may cause injury and/or fire.

Symbols

The followings show the symbols which may be used for the equipment. Be sure that you understand their meaning before use.



Read instruction manual.



Wear safety glasses.



Ni-MH
Li-Ion

Only for EU countries
Do not dispose of electric equipment or battery pack together with household waste material!
In observance of the European Directives, on Waste Electric and Electronic Equipment and Batteries and Accumulators and Waste Batteries and Accumulators and their implementation in accordance with national laws, electric equipment and batteries and battery pack(s) that have reached the end of their life must be collected separately and returned to an environmentally compatible recycling facility.

Intended use

The tool is intended for cutting in metal materials with a abrasive cut-off wheel and also masonry materials with a diamond wheel.

SAFETY WARNINGS

General power tool safety warnings

⚠ WARNING: Read all safety warnings, instructions, illustrations and specifications provided with this power tool. Failure to follow all instructions listed below may result in electric shock, fire and/or serious injury.

Save all warnings and instructions for future reference.

The term "power tool" in the warnings refers to your mains-operated (corded) power tool or battery-operated (cordless) power tool.

Work area safety

1. **Keep work area clean and well lit.** Cluttered or dark areas invite accidents.
2. **Do not operate power tools in explosive atmospheres, such as in the presence of flammable liquids, gases or dust.** Power tools create sparks which may ignite the dust or fumes.
3. **Keep children and bystanders away while operating a power tool.** Distractions can cause you to lose control.

Electrical safety

1. **Power tool plugs must match the outlet. Never modify the plug in any way. Do not use any adapter plugs with earthed (grounded) power tools.** Unmodified plugs and matching outlets will reduce risk of electric shock.
2. **Avoid body contact with earthed or grounded surfaces, such as pipes, radiators, ranges and refrigerators.** There is an increased risk of electric shock if your body is earthed or grounded.
3. **Do not expose power tools to rain or wet conditions.** Water entering a power tool will increase the risk of electric shock.
4. **Do not abuse the cord. Never use the cord for carrying, pulling or unplugging the power tool. Keep cord away from heat, oil, sharp edges or moving parts.** Damaged or entangled cords increase the risk of electric shock.
5. **When operating a power tool outdoors, use an extension cord suitable for outdoor use.** Use of a cord suitable for outdoor use reduces the risk of electric shock.
6. **If operating a power tool in a damp location is unavoidable, use a residual current device (RCD) protected supply.** Use of an RCD reduces the risk of electric shock.
7. **Power tools can produce electromagnetic fields (EMF) that are not harmful to the user.** However, users of pacemakers and other similar medical devices should contact the maker of their device and/ or doctor for advice before operating this power tool.

Personal safety

1. **Stay alert, watch what you are doing and use common sense when operating a power tool. Do not use a power tool while you are tired or under the influence of drugs, alcohol or medication.** A moment of inattention while operating power tools may result in serious personal injury.
2. **Use personal protective equipment. Always wear eye protection.** Protective equipment such as a dust mask, non-skid safety shoes, hard hat or hearing protection used for appropriate conditions will reduce personal injuries.
3. **Prevent unintentional starting. Ensure the switch is in the off-position before connecting to power source and/or battery pack, picking up or carrying the tool.** Carrying power tools with your finger on the switch or energising power tools that have the switch on invites accidents.
4. **Remove any adjusting key or wrench before turning the power tool on.** A wrench or a key left attached to a rotating part of the power tool may result in personal injury.
5. **Do not overreach. Keep proper footing and balance at all times.** This enables better control of the power tool in unexpected situations.

6. **Dress properly. Do not wear loose clothing or jewellery. Keep your hair and clothing away from moving parts.** Loose clothes, jewellery or long hair can be caught in moving parts.
7. **If devices are provided for the connection of dust extraction and collection facilities, ensure these are connected and properly used.** Use of dust collection can reduce dust-related hazards.
8. **Do not let familiarity gained from frequent use of tools allow you to become complacent and ignore tool safety principles.** A careless action can cause severe injury within a fraction of a second.
9. **Always wear protective goggles to protect your eyes from injury when using power tools. The goggles must comply with ANSI Z87.1 in the USA, EN 166 in Europe, or AS/NZS 1336 in Australia/New Zealand. In Australia/New Zealand, it is legally required to wear a face shield to protect your face, too.**

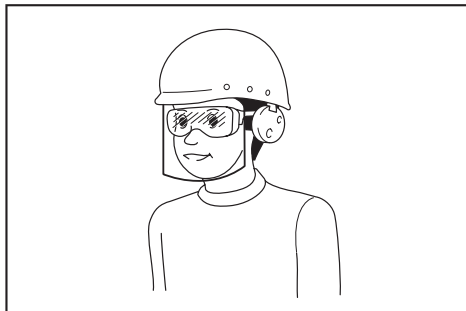

It is an employer's responsibility to enforce the use of appropriate safety protective equipments by the tool operators and by other persons in the immediate working area.

Power tool use and care

1. **Do not force the power tool. Use the correct power tool for your application.** The correct power tool will do the job better and safer at the rate for which it was designed.
2. **Do not use the power tool if the switch does not turn it on and off.** Any power tool that cannot be controlled with the switch is dangerous and must be repaired.
3. **Disconnect the plug from the power source and/or remove the battery pack, if detachable, from the power tool before making any adjustments, changing accessories, or storing power tools.** Such preventive safety measures reduce the risk of starting the power tool accidentally.
4. **Store idle power tools out of the reach of children and do not allow persons unfamiliar with the power tool or these instructions to operate the power tool.** Power tools are dangerous in the hands of untrained users.
5. **Maintain power tools and accessories. Check for misalignment or binding of moving parts, breakage of parts and any other condition that may affect the power tool's operation. If damaged, have the power tool repaired before use.** Many accidents are caused by poorly maintained power tools.

Cordless cutter safety warnings

6. **Keep cutting tools sharp and clean.** Properly maintained cutting tools with sharp cutting edges are less likely to bind and are easier to control.
7. **Use the power tool, accessories and tool bits etc. in accordance with these instructions, taking into account the working conditions and the work to be performed.** Use of the power tool for operations different from those intended could result in a hazardous situation.
8. **Keep handles and grasping surfaces dry, clean and free from oil and grease.** Slippery handles and grasping surfaces do not allow for safe handling and control of the tool in unexpected situations.
9. **When using the tool, do not wear cloth work gloves which may be entangled.** The entanglement of cloth work gloves in the moving parts may result in personal injury.

Battery tool use and care

1. **Recharge only with the charger specified by the manufacturer.** A charger that is suitable for one type of battery pack may create a risk of fire when used with another battery pack.
2. **Use power tools only with specifically designed battery packs.** Use of any other battery packs may create a risk of injury and fire.
3. **When battery pack is not in use, keep it away from other metal objects, like paper clips, coins, keys, nails, screws or other small metal objects, that can make a connection from one terminal to another.** Shorting the battery terminals together may cause burns or a fire.
4. **Under abusive conditions, liquid may be ejected from the battery; avoid contact. If contact accidentally occurs, flush with water. If liquid contacts eyes, additionally seek medical help.** Liquid ejected from the battery may cause irritation or burns.
5. **Do not use a battery pack or tool that is damaged or modified.** Damaged or modified batteries may exhibit unpredictable behaviour resulting in fire, explosion or risk of injury.
6. **Do not expose a battery pack or tool to fire or excessive temperature.** Exposure to fire or temperature above 130 °C may cause explosion.
7. **Follow all charging instructions and do not charge the battery pack or tool outside the temperature range specified in the instructions.** Charging improperly or at temperatures outside the specified range may damage the battery and increase the risk of fire.

Service

1. **Have your power tool serviced by a qualified repair person using only identical replacement parts.** This will ensure that the safety of the power tool is maintained.
2. **Never service damaged battery packs.** Service of battery packs should only be performed by the manufacturer or authorized service providers.
3. **Follow instruction for lubricating and changing accessories.**

1. **The guard provided with the tool must be securely attached to the power tool and positioned for maximum safety, so the least amount of wheel is exposed towards the operator. Position yourself and bystanders away from the plane of the rotating wheel.** The guard helps to protect operator from broken wheel fragments and accidental contact with wheel.
2. **Use only bonded reinforced or diamond cut-off wheels for your power tool.** Just because an accessory can be attached to your power tool, it does not assure safe operation.
3. **The rated speed of the accessory must be at least equal to the maximum speed marked on the power tool.** Accessories running faster than their rated speed can break and fly apart.
4. **Wheels must be used only for recommended applications. For example: do not grind with the side of cut-off wheel.** Abrasive cut-off wheels are intended for peripheral grinding, side forces applied to these wheels may cause them to shatter.
5. **Always use undamaged wheel flanges that are of correct diameter for your selected wheel.** Proper wheel flanges support the wheel thus reducing the possibility of wheel breakage.
6. **Do not use worn down reinforced wheels from larger power tools.** Wheels intended for a larger power tool are not suitable for the higher speed of a smaller tool and may burst.
7. **The outside diameter and the thickness of your accessory must be within the capacity rating of your power tool.** Incorrectly sized accessories cannot be adequately guarded or controlled.
8. **The arbour size of wheels and flanges must properly fit the spindle of the power tool.** Wheels and flanges with arbour holes that do not match the mounting hardware of the power tool will run out of balance, vibrate excessively and may cause loss of control.
9. **Do not use damaged wheels. Before each use, inspect the wheels for chips and cracks. If power tool or wheel is dropped, inspect for damage or install an undamaged wheel. After inspecting and installing the wheel, position yourself and bystanders away from the plane of the rotating wheel and run the power tool at maximum no load speed for one minute.** Damaged wheels will normally break apart during this test time.
10. **Wear personal protective equipment.** Depending on application, use face shield, safety goggles or safety glasses. As appropriate, wear dust mask, hearing protectors, gloves and shop apron capable of stopping small abrasive or workpiece fragments. The eye protection must be capable of stopping flying debris generated by various operations. The dust mask or respirator must be capable of filtrating particles generated by your operation. Prolonged exposure to high intensity noise may cause hearing loss.

11. **Keep bystanders a safe distance away from work area. Anyone entering the work area must wear personal protective equipment.** Fragments of workpiece or of a broken wheel may fly away and cause injury beyond immediate area of operation.
12. **Hold the power tool by insulated gripping surfaces only, when performing an operation where the cutting accessory may contact hidden wiring.** Cutting accessory contacting a “live” wire may make exposed metal parts of the power tool “live” and could give the operator an electric shock.
13. **Never lay the power tool down until the accessory has come to a complete stop.** The spinning wheel may grab the surface and pull the power tool out of your control.
14. **Do not run the power tool while carrying it at your side.** Accidental contact with the spinning accessory could snag your clothing, pulling the accessory into your body.
15. **Regularly clean the power tool's air vents.** The motor's fan will draw the dust inside the housing and excessive accumulation of powdered metal may cause electrical hazards.
16. **Do not operate the power tool near flammable materials.** Sparks could ignite these materials.
5. **Do not attach a saw chain, woodcarving blade, segmented diamond wheel with a peripheral gap greater than 10 mm or toothed saw blade.** Such blades create frequent kickback and loss of control.
6. **Do not “jam” the wheel or apply excessive pressure. Do not attempt to make an excessive depth of cut.** Overstressing the wheel increases the loading and susceptibility to twisting or binding of the wheel in the cut and the possibility of kickback or wheel breakage.
7. **When wheel is binding or when interrupting a cut for any reason, switch off the power tool and hold the power tool motionless until the wheel comes to a complete stop. Never attempt to remove the wheel from the cut while the wheel is in motion otherwise kickback may occur.** Investigate and take corrective action to eliminate the cause of wheel binding.
8. **Do not restart the cutting operation in the workpiece. Let the wheel reach full speed and carefully re-enter the cut.** The wheel may bind, walk up or kickback if the power tool is restarted in the workpiece.
9. **Support panels or any oversized workpiece to minimize the risk of wheel pinching and kickback.** Large workpieces tend to sag under their own weight. Supports must be placed under the workpiece near the line of cut and near the edge of the workpiece on both sides of the wheel.
10. **Use extra caution when making a “pocket cut” into existing walls or other blind areas.** The protruding wheel may cut gas or water pipes, electrical wiring or objects that can cause kickback.

Kickback and related warnings

Kickback is a sudden reaction to a pinched or snagged rotating wheel. Pinching or snagging causes rapid stalling of the rotating wheel which in turn causes the uncontrolled power tool to be forced in the direction opposite of the wheel's rotation at the point of the binding.

For example, if an abrasive wheel is snagged or pinched by the workpiece, the edge of the wheel that is entering into the pinch point can dig into the surface of the material causing the wheel to climb out or kick out. The wheel may either jump toward or away from the operator, depending on direction of the wheel's movement at the point of pinching. Abrasive wheels may also break under these conditions.

Kickback is the result of power tool misuse and/or incorrect operating procedures or conditions and can be avoided by taking proper precautions as given below.

1. **Maintain a firm grip on the power tool and position your body and arm to allow you to resist kickback forces. Always use auxiliary handle, if provided, for maximum control over kickback or torque reaction during start-up.** The operator can control torque reactions or kickback forces, if proper precautions are taken.
2. **Never place your hand near the rotating accessory.** Accessory may kickback over your hand.
3. **Do not position your body in line with the rotating wheel.** Kickback will propel the tool in direction opposite to the wheel's movement at the point of snagging.
4. **Use special care when working corners, sharp edges etc. Avoid bouncing and snagging the accessory.** Corners, sharp edges or bouncing have a tendency to snag the rotating accessory and cause loss of control or kickback.
5. **Before using a segmented diamond wheel, make sure that the diamond wheel has the peripheral gap between segments of 10 mm or less, only with a negative rake angle.**
6. **Never attempt to cut with the tool held upside down in a vise. This can lead to serious accidents, because it is extremely dangerous.**
7. **Some material contains chemicals which may be toxic. Take caution to prevent dust inhalation and skin contact. Follow material supplier safety data.**
8. **Store wheels as per manufacturer recommendations. Improper storage may damage the wheels.**
9. **Always use the wheel suitable for your work and the material to be cut.**
10. **Examine the material to be cut before cutting.** If the material contains explosive or flammable substances, it may cause an explosion or fire.
7. **Do not switch on the tool if a foreign object is jammed between the guard and the wheel.** In this case, uninstall the battery cartridge and remove the foreign object.
8. **Use clamps or similar to support the workpiece whenever possible.**
9. **Always wear hearing protection during operation.**
10. **Do not cut wood materials with this tool.**

SAVE THESE INSTRUCTIONS.

⚠WARNING: DO NOT let comfort or familiarity with product (gained from repeated use) replace strict adherence to safety rules for the subject product. MISUSE or failure to follow the safety rules stated in this instruction manual may cause serious personal injury.

Important safety instructions for battery cartridge

1. Before using battery cartridge, read all instructions and cautionary markings on (1) battery charger, (2) battery, and (3) product using battery.
2. Do not disassemble or tamper the battery cartridge. It may result in a fire, excessive heat, or explosion.
3. If operating time has become excessively shorter, stop operating immediately. It may result in a risk of overheating, possible burns and even an explosion.
4. If electrolyte gets into your eyes, rinse them out with clear water and seek medical attention right away. It may result in loss of your eyesight.
5. Do not short the battery cartridge:
 - (1) Do not touch the terminals with any conductive material.
 - (2) Avoid storing battery cartridge in a container with other metal objects such as nails, coins, etc.
 - (3) Do not expose battery cartridge to water or rain.

A battery short can cause a large current flow, overheating, possible burns and even a breakdown.
6. Do not store and use the tool and battery cartridge in locations where the temperature may reach or exceed 50 °C (122 °F).
7. Do not incinerate the battery cartridge even if it is severely damaged or is completely worn out. The battery cartridge can explode in a fire.
8. Do not nail, cut, crush, throw, drop the battery cartridge, or hit against a hard object to the battery cartridge. Such conduct may result in a fire, excessive heat, or explosion.
9. Do not use a damaged battery.
10. The contained lithium-ion batteries are subject to the Dangerous Goods Legislation requirements.

For commercial transports e.g. by third parties, forwarding agents, special requirement on packaging and labeling must be observed.
For preparation of the item being shipped, consulting an expert for hazardous material is required.
Please also observe possibly more detailed national regulations.
Tape or mask off open contacts and pack up the battery in such a manner that it cannot move around in the packaging.
11. When disposing the battery cartridge, remove it from the tool and dispose of it in a safe place. Follow your local regulations relating to disposal of battery.

12. Use the batteries only with the products specified by Makita. Installing the batteries to non-compliant products may result in a fire, excessive heat, explosion, or leak of electrolyte.
13. If the tool is not used for a long period of time, the battery must be removed from the tool.
14. During and after use, the battery cartridge may take on heat which can cause burns or low temperature burns. Pay attention to the handling of hot battery cartridges.
15. Do not touch the terminal of the tool immediately after use as it may get hot enough to cause burns.
16. Do not allow chips, dust, or soil stuck into the terminals, holes, and grooves of the battery cartridge. It may result in poor performance or breakdown of the tool or battery cartridge.
17. Unless the tool supports the use near high-voltage electrical power lines, do not use the battery cartridge near high-voltage electrical power lines. It may result in a malfunction or breakdown of the tool or battery cartridge.
18. Keep the battery away from children.

SAVE THESE INSTRUCTIONS.

⚠CAUTION: Only use genuine Makita batteries. Use of non-genuine Makita batteries, or batteries that have been altered, may result in the battery bursting causing fires, personal injury and damage. It will also void the Makita warranty for the Makita tool and charger.

Tips for maintaining maximum battery life

1. Charge the battery cartridge before completely discharged. Always stop tool operation and charge the battery cartridge when you notice less tool power.
2. Never recharge a fully charged battery cartridge. Overcharging shortens the battery service life.
3. Charge the battery cartridge with room temperature at 10 °C - 40 °C (50 °F - 104 °F). Let a hot battery cartridge cool down before charging it.
4. When not using the battery cartridge, remove it from the tool or the charger.
5. Charge the battery cartridge if you do not use it for a long period (more than six months).

PARTS DESCRIPTION

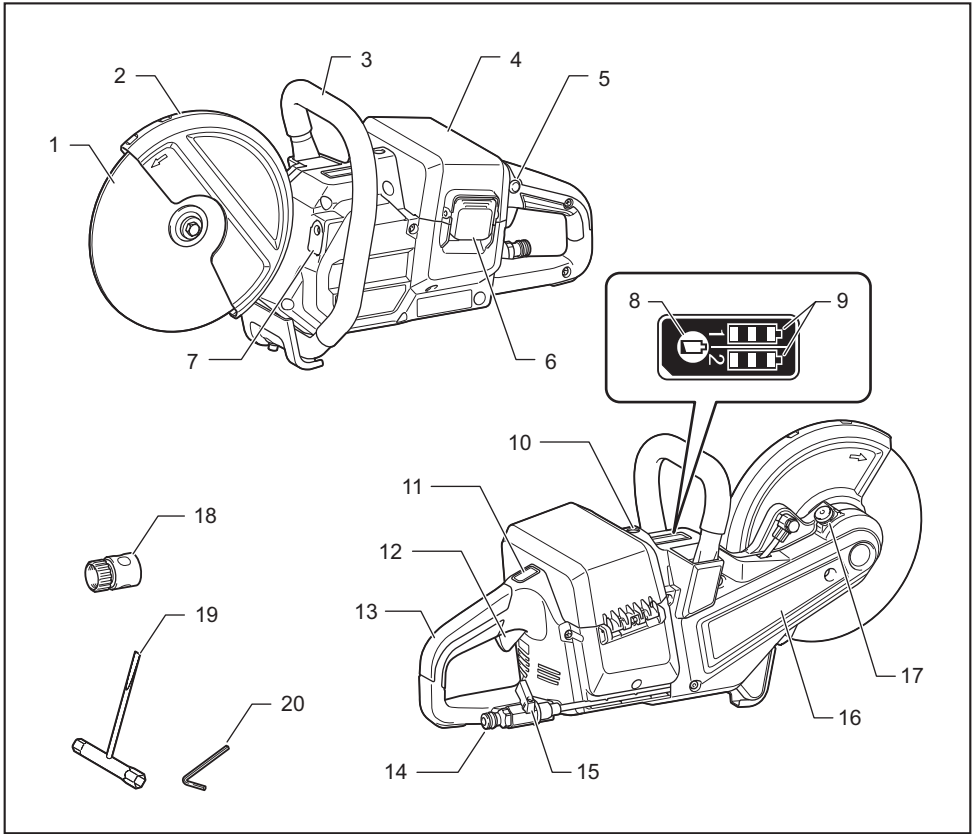

1	Abrasive cut-off wheel / diamond wheel	2	Wheel guard	3	Grip	4	Cover (for battery compartment)
5	Lock-off button	6	Hook	7	Lamp	8	Check button
9	Battery indicator	10	Overload indicator	11	Lamp button	12	Switch trigger
13	Handle	14	Water inlet	15	Cock	16	Cover (for V-belt)
17	Shaft lock button	18	Coupling sleeve	19	Box wrench	20	Hex wrench

FUNCTIONAL DESCRIPTION

CAUTION: Always be sure that the tool is switched off and the battery cartridge is removed before adjusting or checking function on the tool.

Installing or removing battery cartridge

CAUTION: Always switch off the tool before installing or removing of the battery cartridge.

CAUTION: Hold the tool and the battery cartridge firmly when installing or removing battery cartridge. Failure to hold the tool and the battery cartridge firmly may cause them to slip off your hands and result in damage to the tool and battery cartridge and a personal injury.

To install the battery cartridge, open the cover while releasing the hook. Align the tongue on the battery cartridge with the groove in the housing and slip it into place. Insert it all the way until it locks in place with a little click. If you can see the red indicator on the upper side of the button, it is not locked completely. After installing or removing the battery cartridges, make sure that the cover is closed and locked by the hook.

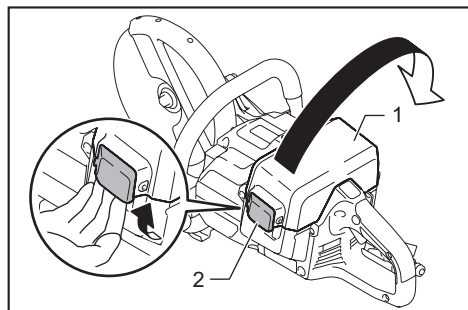

► 1. Cover 2. Hook

To remove the battery cartridges, lift the battery cartridge while pushing the button on the front of the cartridge.

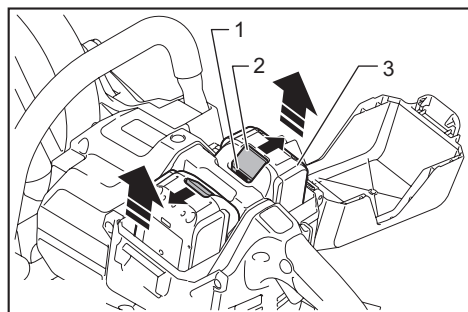

► 1. Red indicator 2. Button 3. Battery cartridge

CAUTION: Always install the battery cartridge fully until the red indicator cannot be seen. If not, it may accidentally fall out of the tool, causing injury to you or someone around you.

CAUTION: Do not install the battery cartridge forcibly. If the cartridge does not slide in easily, it is not being inserted correctly.

NOTE: The tool does not work with only one battery cartridge.

Indicating the remaining battery capacity

Only for battery cartridges with the indicator

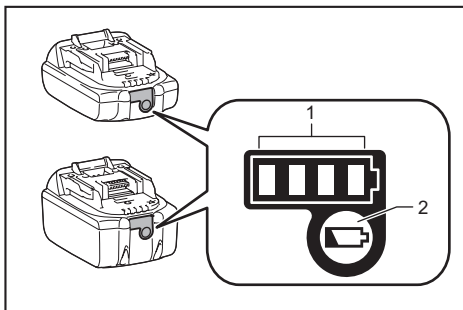

► 1. Indicator lamps 2. Check button

Press the check button on the battery cartridge to indicate the remaining battery capacity. The indicator lamps light up for a few seconds.

Indicator lamps			Remaining capacity
Lighted	Off	Blinking	
■ ■ ■ ■			75% to 100%
■ ■ ■ □			50% to 75%
■ ■ □ □			25% to 50%
■ □ □ □			0% to 25%
▬ □ □ □			Charge the battery.
■ ■ □ □			The battery may have malfunctioned.
□ □ ■ ■			

NOTE: Depending on the conditions of use and the ambient temperature, the indication may differ slightly from the actual capacity.

NOTE: The first (far left) indicator lamp will blink when the battery protection system works.

Indicating the remaining battery capacity

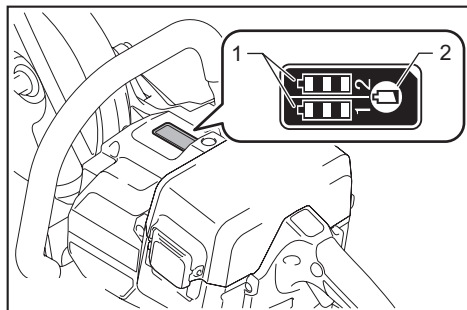

► 1. Battery indicator 2. Check button

Press the check button to indicate the remaining battery capacities. The battery indicators correspond to each battery.

Battery indicator status			Remaining battery capacity
On	Off	Blinking	
			50% to 100%
			20% to 50%
			0% to 20%
			Charge the battery

Tool / battery protection system

The tool is equipped with a tool/battery protection system. This system automatically cuts off power to the motor to extend tool and battery life. The tool will automatically stop during operation if the tool or battery is placed under one of the following conditions.

Overload protection

When the tool/battery is operated in a manner that causes it to draw an abnormally high current, the tool automatically stops. In this situation, turn the tool off and stop the application that caused the tool to become overloaded. Then turn the tool on to restart.

Overheat protection

When the tool is overheated, the tool stops automatically, and the battery indicator blink about 60 seconds. In this situation, let the tool cool down before turning the tool on again.

On	Blinking

Overdischarge protection

When the battery capacity becomes low, the tool stops automatically. If the product does not operate even when the switches are operated, remove the batteries from the tool and charge the batteries.

Overload alert

If the tool is operated with excessive load, the overload indicator will blink in red. In this situation, reduce the load on the tool. Then, the indicator stops blinking.

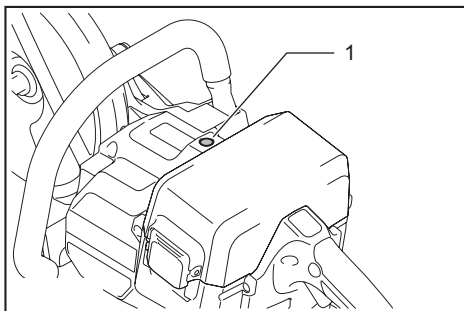

► 1. Overload indicator

Switch action

⚠ WARNING: Before installing the battery cartridge into the tool, always check to see that the switch trigger actuates properly and returns to the "OFF" position when released.

⚠ WARNING: NEVER defeat the lock-off button by taping down or some other means. A switch with a negated lock-off button may result in unintentional operation and serious personal injury.

⚠ WARNING: NEVER use the tool if it runs when you simply pull the switch trigger without pressing the lock-off button. A switch in need of repair may result in unintentional operation and serious personal injury. Return tool to a Makita service center for proper repairs BEFORE further usage.

To prevent the switch trigger from being accidentally pulled, a lock-off button is provided. To start the tool, depress the lock-off button and pull the switch trigger. Release the switch trigger to stop.

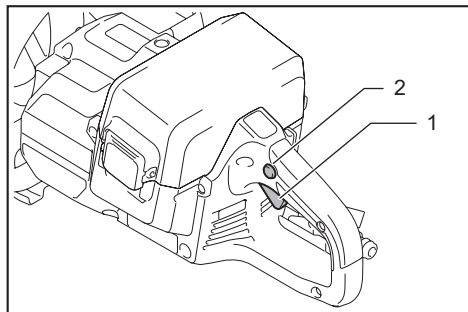

► 1. Switch trigger 2. Lock-off button

NOTICE: Do not pull the switch trigger hard without pressing in the lock-off button. This can cause switch breakage.

Lighting the lamp

CAUTION: Do not look in the light or see the source of light directly.

To turn on the lamp, press the lamp button. To turn off, press the lamp button again.

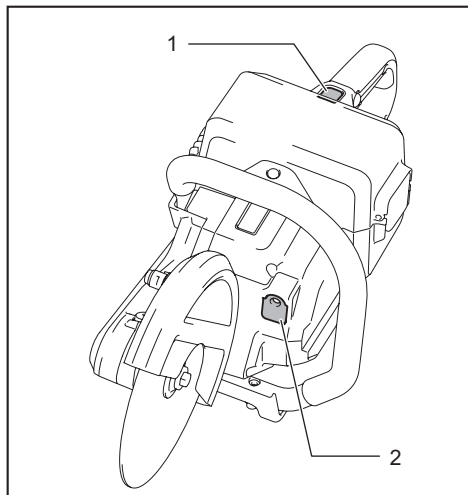

► 1. Lamp button 2. Lamp

NOTE: The lamp will automatically be turned off if there is no operation with the tool for one minute.

ASSEMBLY

CAUTION: Always be sure that the tool is switched off and the battery cartridge is removed before carrying out any work on the tool.

Installing or removing abrasive cut-off wheel / diamond wheel

CAUTION: Use only the Makita wrench to install or remove the wheel.

CAUTION: When installing the wheel, be sure to tighten the bolt securely.

CAUTION: Do not press the shaft lock button when the wheel is rotating.

To remove the wheel, press the shaft lock button and rotate the wheel until the wheel cannot revolve. While the shaft lock is fully locked, turn the hex bolt counter-clockwise using the box wrench. Then remove the hex bolt, outer flange and wheel.

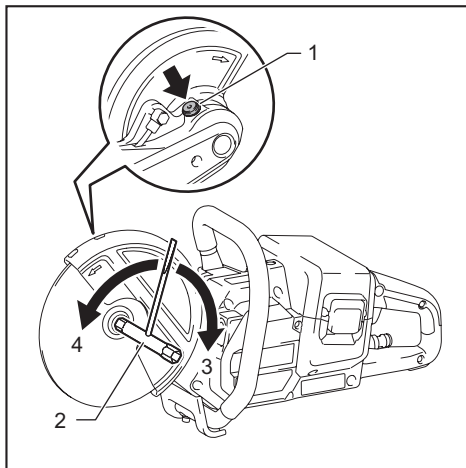

► 1. Shaft lock button 2. Box wrench 3. Tighten 4. Loosen

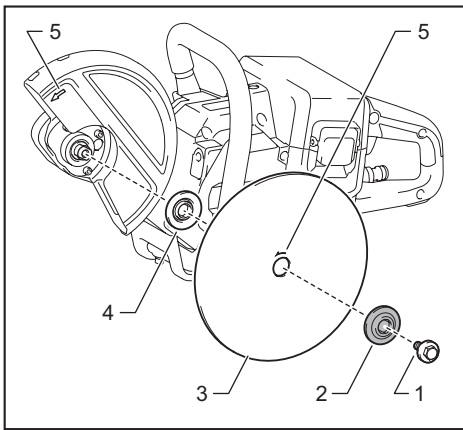

- 1. Hex bolt 2. Outer flange (black) 3. Abrasive cut-off wheel / diamond wheel 4. Inner flange (silver) 5. Arrow (rotation direction of the wheel)

To install the wheel, follow the removal procedure in reverse.
BE SURE TO TIGHTEN THE HEX BOLT SECURELY.

CAUTION: Always install the wheel so that the arrow on it points in the same direction as the arrow on the wheel guard. Otherwise the wheel rotates in reverse, it may cause personal injury.

CAUTION: Only use the wheel that are marked with a speed equal or higher than the speed marked on the tool.

NOTE: If an inner flange is removed by chance, install the inner flange so that taller protrusion faces the tool side as shown in the figure.

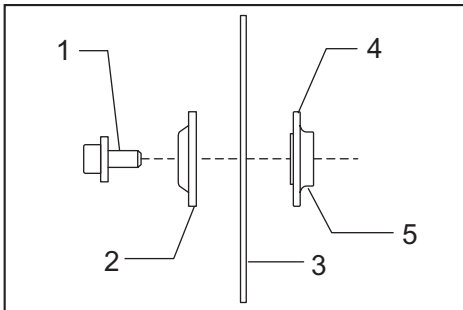

- 1. Hex bolt 2. Outer flange (black) 3. Abrasive cut-off wheel / diamond wheel 4. Inner flange (silver) 5. Protrusion (taller)

Connecting to water supply

1. Prepare a water hose.

2. Remove the nut on the coupling sleeve and pass the water hose through the nut. Insert the end of the hose into the coupling sleeve and then tighten the nut.

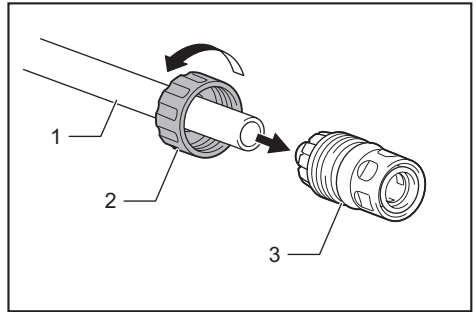

- 1. Water hose 2. Nut of the coupling sleeve 3. Coupling sleeve

3. Connect the water hose to the water supply.
 When connecting to a water faucet, use a suitable fitting such as hose band or water tap joint.

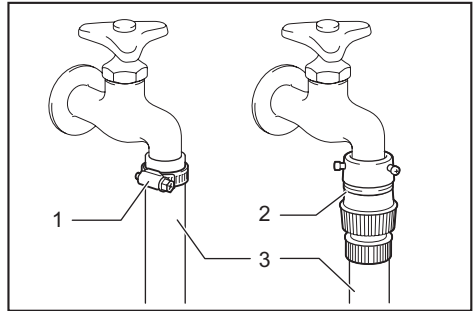

- 1. Hose band 2. Water tap joint 3. Water hose

NOTE: The fitting depends on the shape of the faucet to which you connect. Prepare a suitable commercially-bought fitting.

NOTE: If you use a water tap joint, prepare another coupling sleeve and attach it to the other end of the hose.

NOTE: When using a water pump, follow the instructions of your water pump to connect the water hose.

4. Push the coupling sleeve into the water inlet until it locks with a click.

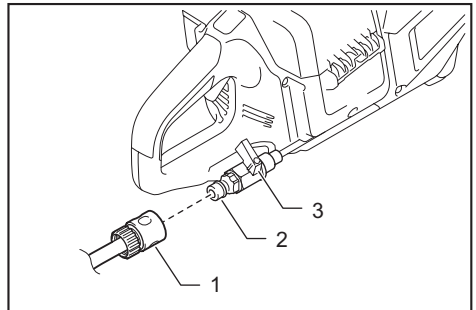

- 1. Coupling sleeve 2. Water inlet 3. Cock

NOTICE: Keep the cock closed until you start the cutting operation with water feeding. For how to feed water, refer to the section for the operation.

OPERATION

CAUTION: Be sure to lock the cover for battery compartment before operating.

CAUTION: Be sure to hold the workpiece firmly down on a stable bench or table during operation.

CAUTION: Do not twist or force the tool in the cut, or the motor may be overloaded or the workpiece may break.

Cutting

CAUTION: During operation, do not bring the tool higher than your shoulder height.

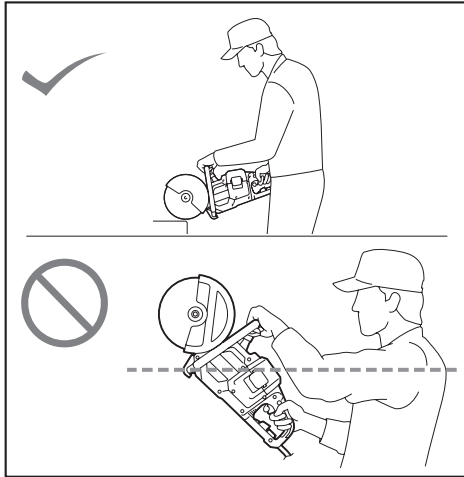

Hold the tool firmly. Grasp the handle with your right hand and the grip with your left hand. To prevent electric shock by accidental cutting of an electric cable, always hold the grip by the designated portion as shown in the figure.

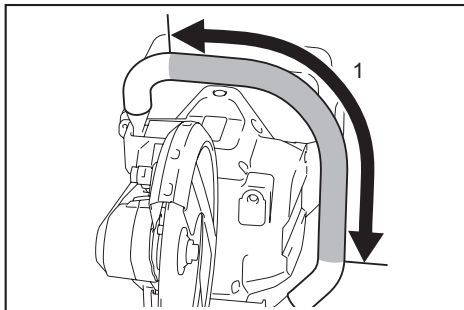

► 1. Part to hold

Move the tool over the workpiece surface, keeping it flat and advancing smoothly until the cutting is completed. Keep your cutting line straight and your speed of advance uniform.

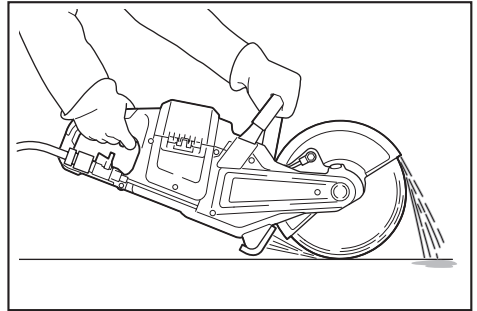

NOTE: When the battery cartridge temperature is low, the tool may not work to its full capacity. At this time, for example, use the tool for a light-duty cut for a while until the battery cartridge warms up as high as room temperature. Then, the tool can work to its full capacity.

NOTE: If the cutting action of the diamond wheel begins to diminish, dress the cutting edge of the wheel using an old discarded coarse grit bench grinder wheel or concrete block. Dress by pressing lightly on the outer edge of the diamond wheel.

When feeding water during cutting

CAUTION: When using a wet-type diamond wheel, always feed water during cutting.

Connect the tool to the water supply and turn the cock in the direction of the arrow as illustrated. Adjust the position of the cock to obtain a gentle flow of water.

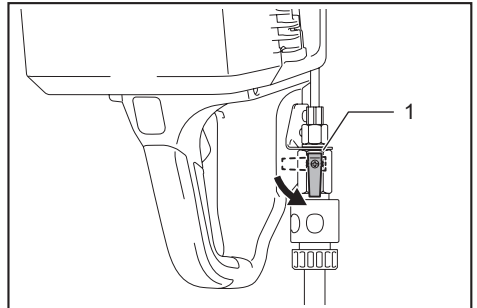

► 1. Cock

CAUTION: When feeding water, always keep the tool head lower than the tool body to prevent water entering into the tool mechanism. Failure to do so may cause electric shock.

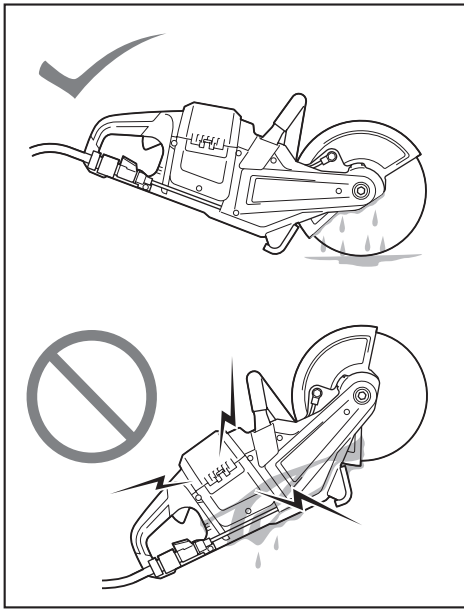

Cleaning the tool

After each use, remove the battery cartridge and the wheel and then clean dust, dirt or metal chips accumulated inside the wheel guard. Clean the tool body by wiping off dust, dirt with a dry cloth or one dipped in soapy water and wrung out. Use a dry cloth to wipe the dirt off the lens of the lamp. Be careful not to scratch the lens of lamp, or it may lower the illumination.

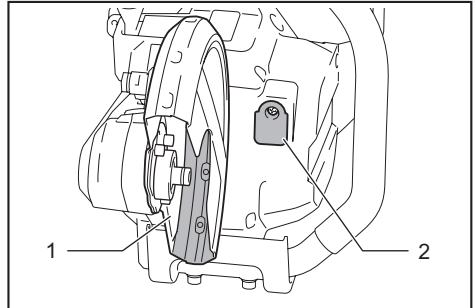

► 1. Wheel guard 2. Lens of the lamp

MAINTENANCE

CAUTION: Always be sure that the tool is switched off and the battery cartridge is removed before attempting to perform inspection or maintenance.

NOTICE: Never use gasoline, benzine, thinner, alcohol or the like. Discoloration, deformation or cracks may result.

To maintain product SAFETY and RELIABILITY, repairs, any other maintenance or adjustment should be performed by Makita Authorized or Factory Service Centers, always using Makita replacement parts.

Cleaning the air vent

Regularly clean the tool's air vents or whenever the vents start to become obstructed.

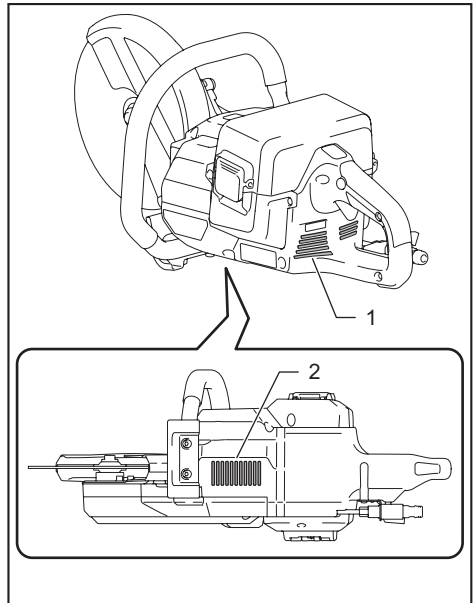

► 1. Inhalation vent 2. Exhaust vent

Changing the V-belt

1. Remove the battery cartridge and the wheel.
2. Loosen the hex socket bolts using the hex wrench and then remove the cover .

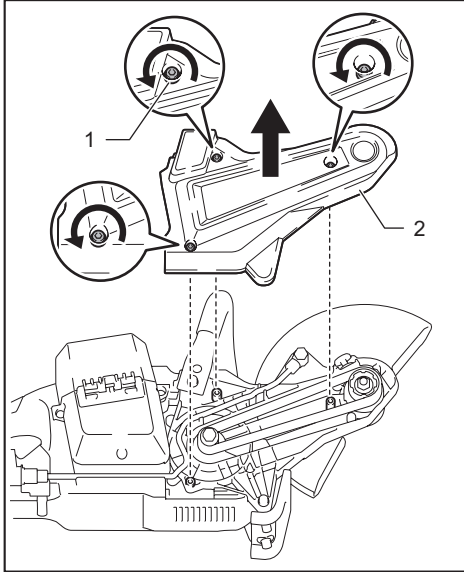

► 1. Hex socket bolt 2. Cover

3. While strongly twisting the V-belt so that its inner side faces up as shown in the figure, turn the bolt on the pulley (large) clockwise using the box wrench. The V-belt will deviate from the track and come off as you turn the bolt.

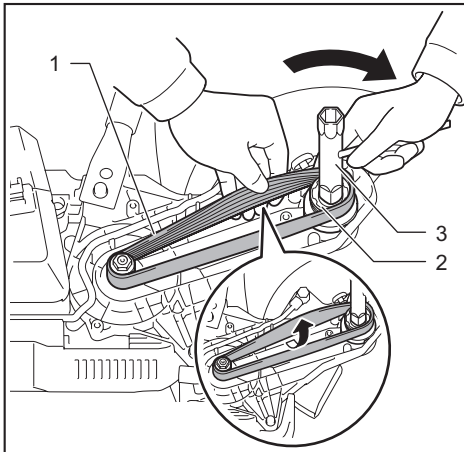

► 1. V-belt 2. Pulley (large) 3. Box wrench

NOTICE: Never turn the box wrench counter-clockwise. Doing so loosens the bolt on the pulley (large) and result in poor performance.

4. Hook the new V-belt to the pulley (small). Put the other end of the V-belt onto the pulley (large) so that it is partially hooked on the forefront rail of the pulley. (You don't have to hook the V-belt to all of the rails on the pulley at this stage). After that, turn the bolt on the pulley (large) clockwise using the box wrench.

The V-belt will get on the track as you turn the bolt.

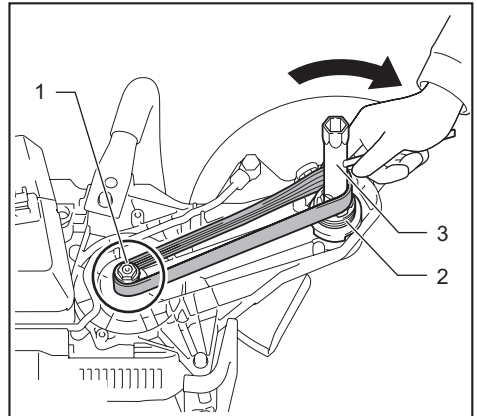

► 1. Pulley (small) 2. Pulley (large) 3. Box wrench

Make sure that all the guides on the internal circle of the V-belt fit into the rails on the pulleys. All the rails on the pulley must support the guides on the V-belt. If there is a rail which does not support the guide, the V-belt is not properly installed.

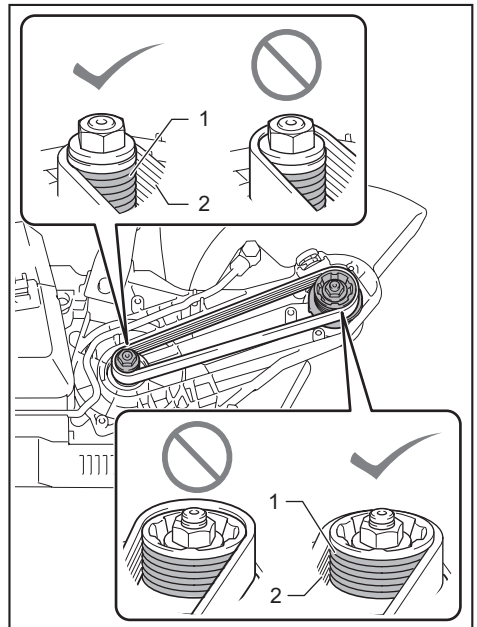

► 1. Rail on the pulley 2. Guide on the V-belt

5. Place the cover onto the tool and tighten the hex socket bolts using the hex wrench.

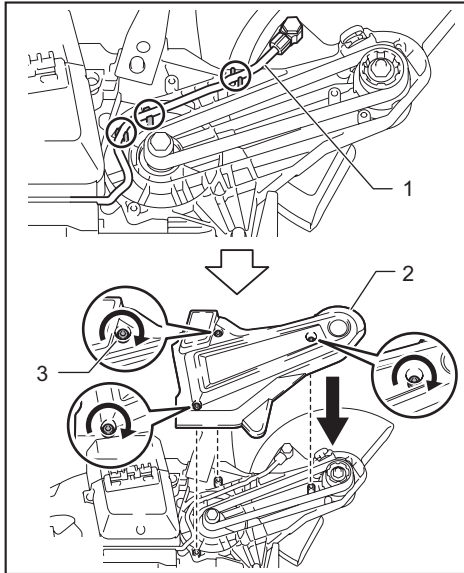

► 1. Tube 2. Cover 3. Hex socket bolt

NOTICE: Make sure that the tube for water feed is in the positions as shown in the figure before attaching the cover.

TROUBLESHOOTING

Before asking for repairs, conduct your own inspection first. If you find a problem that is not explained in the manual, do not attempt to dismantle the tool. Instead, ask Makita Authorized Service Centers, always using Makita replacement parts for repairs.

State of abnormality	Probable cause (malfunction)	Remedy
Motor does not run.	Battery cartridges are not installed.	Install two battery cartridges. This tool does not work with one battery cartridge.
	Battery problem (under voltage)	Recharge the battery. If recharging is not effective, replace the battery cartridge.
	The drive system does not work correctly.	Ask your local authorized service center for repair.
Motor stops running after a little use.	Battery's charge level is low.	Recharge the battery. If recharging is not effective, replace the battery cartridge.
	Overheating.	Stop using of tool to allow it to cool down.
The wheel rotation does not accelerate properly even after running the tool without load for 20 seconds.	Battery is installed improperly.	Install the battery cartridge as described in this manual.
	Battery power is dropping.	Recharge the battery cartridge. If recharging is not effective, replace the battery cartridge.
	The V-belt is slipping.	Replace the V-belt with new one.
	The drive system does not work correctly.	Ask your local authorized service center for repair.
Wheel does not rotate: ⇒ stop the machine immediately!	The V-belt is slipping.	Replace the V-belt with new one.
	Foreign object is jammed between the guard and the wheel.	Uninstall the battery cartridge and then remove the foreign object.
	The drive system does not work correctly.	Ask your local authorized service center for repair.
Abnormal vibration: ⇒ stop the machine immediately!	Improper attachment of the wheel.	Install the wheel as instructed in this manual. Tighten the bolt to secure the wheel firmly.
	The drive system does not work correctly.	Ask your local authorized service center for repair.

State of abnormality	Probable cause (malfunction)	Remedy
Cutting tool and motor cannot stop: ⇒ Remove the battery cartridge immediately!	Electric or electronic malfunction.	Remove the battery cartridge and ask your local authorized service center for repair.
Poor cutting performance	It is time to replace the wheel.	Replace the wheel with new one.
Water leaks from the inlet.	Water is leaking from the O-ring part.	Ask your local authorized service center for repair.

OPTIONAL ACCESSORIES

⚠ CAUTION: These accessories or attachments are recommended for use with your Makita tool specified in this manual. The use of any other accessories or attachments might present a risk of injury to persons. Only use accessory or attachment for its stated purpose.

If you need any assistance for more details regarding these accessories, ask your local Makita Service Center.

- Abrasive cut-off wheel
- Diamond wheel
- V-belt
- Coupling sleeve
- Flange 60 set (country specific)
- Box wrench
- Hex wrench
- Makita genuine battery and charger

NOTE: Some items in the list may be included in the tool package as standard accessories. They may differ from country to country.

Makita Corporation
 3-11-8, Sumiyoshi-cho,
 Anjo, Aichi 446-8502 Japan
www.makita.com

885786A928 EN 20200514
