

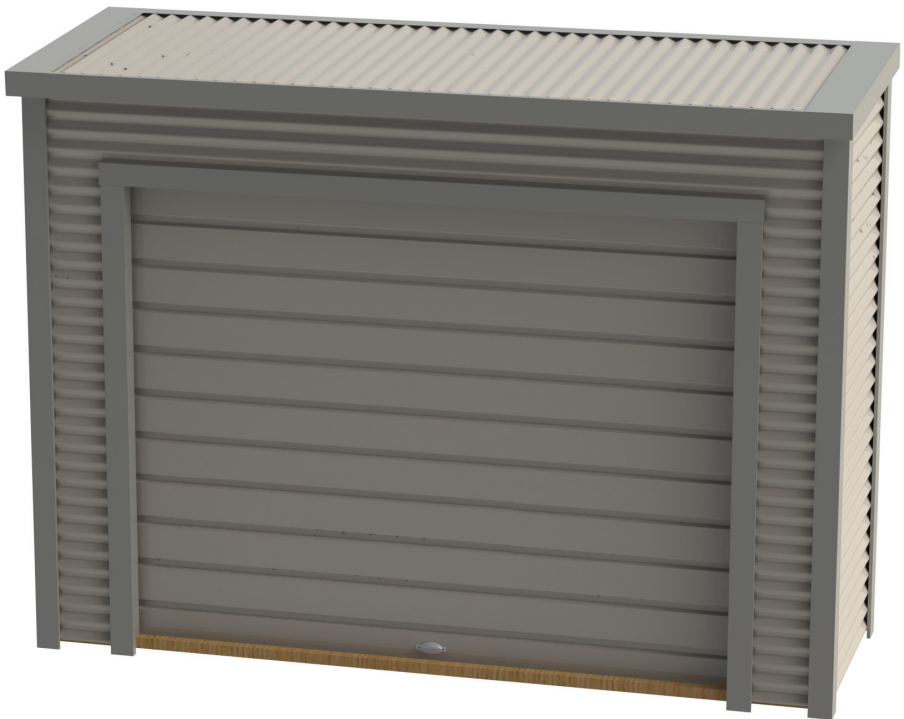

## **ASSEMBLY INSTRUCTIONS**



## **FENDALTON**

**BASE SIZE: 3.150m x 1.000m**

## **BEFORE YOU BEGIN THE ASSEMBLY PLEASE NOTE SOME IMPORTANT POINTS**

### ***TOOLS REQUIRED***

- Drill
- Hex Drive (5/16)
- Drill Bit 3.5mm
- Drill Bit 10mm
- Square Drive Drill Bit
- Phillips Drill Bit
- Slotted Drill Bit
- Riveter
- Hammer
- Tape Measure
- Ladder
- String Line
- Adjustable Spanner
- Level
- Hand Saw
- Caulking Gun
- Tin Snips (Left & Right Hand)
- Flat file (For Roller Door)
- Pipe Wrench (For Roller Door)
- Skillsaw and Jigsaw (For optional timber floor)
- Masonry Drill and 12mm Masonry Bit (for concrete floor)

### ***BEFORE YOU START***

- Read all instructions carefully.
- Identify all parts and check quantities against checklist, before starting.

### ***SAFETY***

- Do not attempt to build your shed in high winds.
- Beware of sharp edges.
- Protect your eyes and ears.
- Use electronic tools with care. Use a Safety Trip Switch.
- It is easier and quicker if this shed is erected by two people.

### ***SELECT YOUR SITE***

- Your shed must be level. Achieve this by either levelling the ground or by using blocks.
- If your shed is to be positioned on wet or damp ground, we recommend that your shed is raised up off the ground slightly.









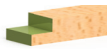

### ***WARRANTY REQUIREMENTS***

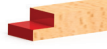
The following maintenance process needs to be adhered to, to qualify for the steel warranty of your Duratuf Guardian shed.





- Wash all surfaces annually using a hose and soft nylon brush.
- Within 2 km of coast – wash every 3 months as above. After a storm, wash the cladding and the gutters as soon as possible to remove any highly corrosive salt deposits.
- Volcanic Ash Fallout – wash as soon as possible, removing fall out from roof and gutters.
- Do not allow manures, chemicals or other corrosive materials to have direct contact with cladding.





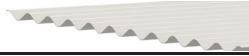
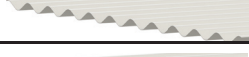

# PARTS LIST

## TIMBER









DESCRIPTION	LENGTH	QTY	DIAGRAM	CHECKED
Front/Back Base Plate 45 x 45 H4 (Green)	3.150m	2		<input type="checkbox"/>
End Base Plate 45 x45 H4 (Green)	1.000m	2		<input type="checkbox"/>
Front/Back Top Plate 45 x 45 H1 (Red)	3.150m	2		<input type="checkbox"/>
End Top Plate 45 x 45 H1 (Red)	1.000m	2		<input type="checkbox"/>
Lintel 45 x 45 H1	2.400m	1		<input type="checkbox"/>
Stud 45 x 45 H1 (Yellow)	2.295m	10		<input type="checkbox"/>
Stud 45 x 45 H1 (Yellow)	0.320m	3		<input type="checkbox"/>
Top Plate Packer 45 x 45 H1	3.150m	1		<input type="checkbox"/>
Nog 45 x 45 H1	0.910m	2		<input type="checkbox"/>
Nog 45 x 45 H1	0.990m	3		<input type="checkbox"/>
Nog 45 x 45 H1	0.240m	2		<input type="checkbox"/>

## CLADDING/FLASHING

DESCRIPTION	LENGTH	QTY	DIAGRAM	CHECKED
Back Wall Sheet	3.150m	3		<input type="checkbox"/>
End Wall Sheet	1.000m	6		<input type="checkbox"/>
Roof Sheet	1.100m	4		<input type="checkbox"/>
Front Wall Sheet	0.375m	6		<input type="checkbox"/>
Half Front Wall Sheet (390mm wide)	3.150m	1		<input type="checkbox"/>
Roller Door	2.400m	1		<input type="checkbox"/>

DESCRIPTION	LENGTH	QTY	PART#	DIAGRAM	CHECKED
Corner Flashing	2.364m	4	1001		<input type="checkbox"/>
Door Top Flashing	2.590m	1	1002		<input type="checkbox"/>
Door Head Flashing	2.400m	1	1003		<input type="checkbox"/>
Door Jamb Flashing	1.964m	2	1004		<input type="checkbox"/>
Barge Flashing	1.188m	2	1005		<input type="checkbox"/>
Spouting	3.265m	1	1006		<input type="checkbox"/>
Ridge	3.265m	1	1007		<input type="checkbox"/>

## HARDWARE/ACCESSORIES







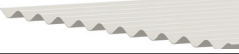

DESCRIPTION	LENGTH	QTY	DIAGRAM	CHECKED
Flathead Nails	75mm	120		<input type="checkbox"/>
Tek Screws	55mm	55		<input type="checkbox"/>
Tek Screws	25mm	10		<input type="checkbox"/>
Clouts	30mm	110		<input type="checkbox"/>
Clouts	50mm	15		<input type="checkbox"/>
Screws	30mm	165		<input type="checkbox"/>
Rivets	3.2mm	70		<input type="checkbox"/>
Roll of DPC- 75mm wide	30m	1		<input type="checkbox"/>
Touch up paint and brush		1		<input type="checkbox"/>

# OPTIONAL EXTRAS







## CLEAR ROOF

DESCRIPTION	LENGTH	QTY	DIAGRAM	CHECKED
Clear Roof Panel	1.100m	1		<input type="checkbox"/>

## PLY FLOOR

DESCRIPTION	LENGTH	QTY	DIAGRAM	CHECKED
Plywood 17mm treated	2.400m x 0.955m	1		<input type="checkbox"/>
Plywood 17mm treated	0.750m x 0.955m	1		<input type="checkbox"/>
Plywood 17mm treated	0.240m x 0.045m	2		<input type="checkbox"/>
Joists 45 x 45 H4	3.060m	1		<input type="checkbox"/>
Joists 45 x 45 H4	0.865m	3		<input type="checkbox"/>
Aluminium Door Step Flashing	2.395m	1		<input type="checkbox"/>
Floor Screws	40mm	50		<input type="checkbox"/>
Floor Screws	75mm	22		<input type="checkbox"/>

## DOWNPIPE KIT

DESCRIPTION	LENGTH	QTY	PART#	DIAGRAM	CHECKED
Downpipe Cover Flashing	2.200m	1	1008		<input type="checkbox"/>
Spouting End Cap	0.080m	2	1009		<input type="checkbox"/>
Dropper		1			<input type="checkbox"/>
Hose 19mm	2.400m	1			<input type="checkbox"/>
Hose Clip		1			<input type="checkbox"/>
Silicone		1			<input type="checkbox"/>

DATE: / /

PACKED BY:

# FOUNDATIONS

- No doubt by now you will have decided what sort of base you are putting down.
- If you choose a concrete base, the shed design prevents the water from flowing inside the shed.
- If you chose to position the shed directly onto the ground, the water can flow down the walls and under the bottom plate and into the shed.

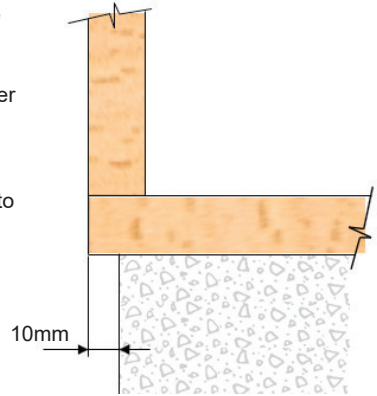

## CONCRETE BASE

- To build a concrete base we recommend the following.
- Concrete base should be 3130mm x 980mm (this is 20mm smaller than the shed frame size, which allows for a 10mm gap around the perimeter of the shed).



- Concrete base to be a minimum of 80mm thick and at least 100mm thick around the perimeter. Base should be at least 50mm above ground line.
- Concrete base should be laid on a solid or compacted base.
- Plastic sheeting underneath concrete will prevent moisture coming through underneath.
- Ideally the area around the doorway should have a slight slope to allow water to run off. Refer to plans for doorway position.

# TIMBER FRAME

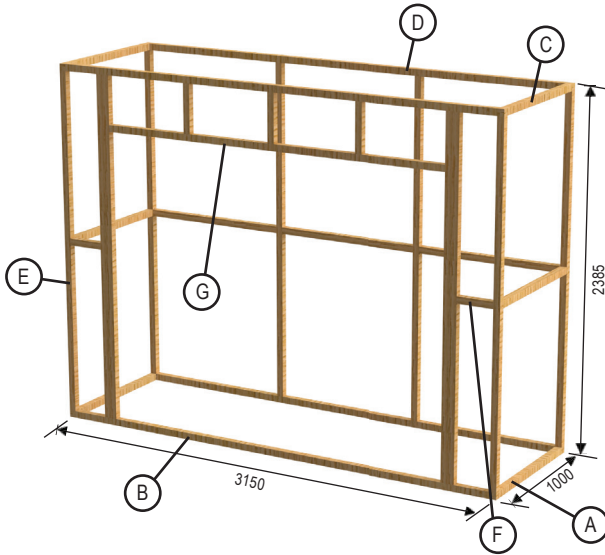

- (A) End Base Plates - 2
- (B) Front/Back Base Plates - 2
- (C) End Top plates - 2
- (D) Front/Back Top Plates - 2
- (E) Studs - 10
- (F) Nogs - 7
- (G) Lintel - 1

## TIMBER FRAME - BACK WALL

Select

- 1 x 3150mm Base Plate
- 1 x 3150mm Top Plate
- 4 x 2295mm Studs
- 3 x 990mm Nogs

- Select one 3150mm base plate (Green), one 3150mm top plate (Red) and four studs (Yellow).
- Lay out plates and four studs on a flat surface ensuring notches face outwards as shown. Nail together using two 75mm nails per joint. Studs are positioned 990mm apart.
- Position nogs 1200mm up from underside of bottom plate to centre of nog and nail in place.

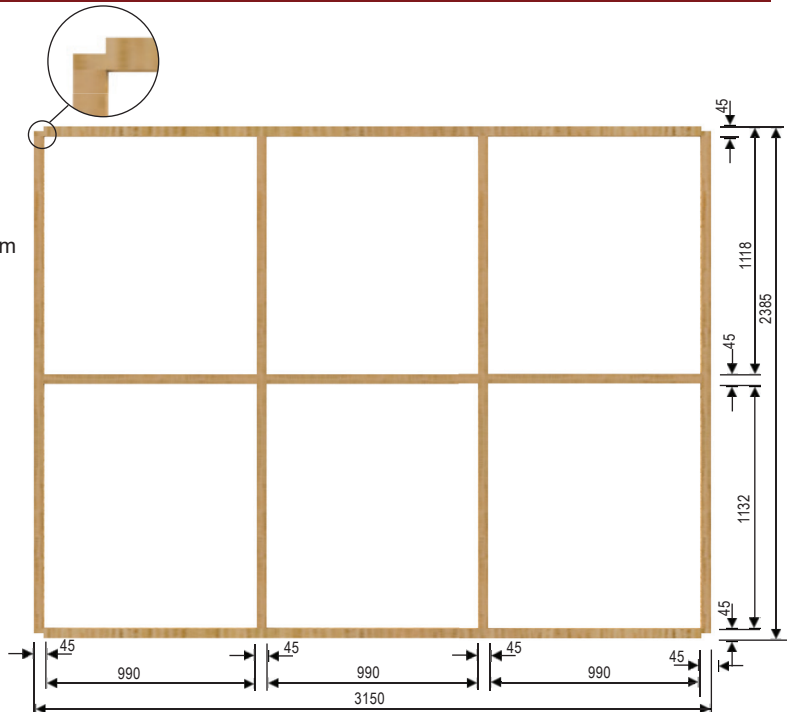

# TIMBER FRAME - FRONT WALL

Select

- 1 x 3150mm Base Plate
- 1 x 3150mm Top Plate
- 1 x 2400mm Lintel
- 6 x 2295mm Studs
- 3 x 320mm Studs
- 2 x 240mm Nogs

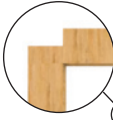

- Select one 3150mm base plate (Green), one 3150mm top plate (Red) and four studs (Yellow). Lay out plates and two studs on a flat surface ensuring notches face outwards as shown. Nail together using two 75mm nails per join.
- Nail one stud each side of doorway to top and bottom using the 240mm nogs to establish correct position.
- Nail remaining two studs to inside of studs and top and bottom plates to make a double stud each side of doorway opening.
- Nail lintel to studs using the 320mm studs to establish correct height.
- Nail 320mm studs to top plate and lintel, spacing these evenly apart.

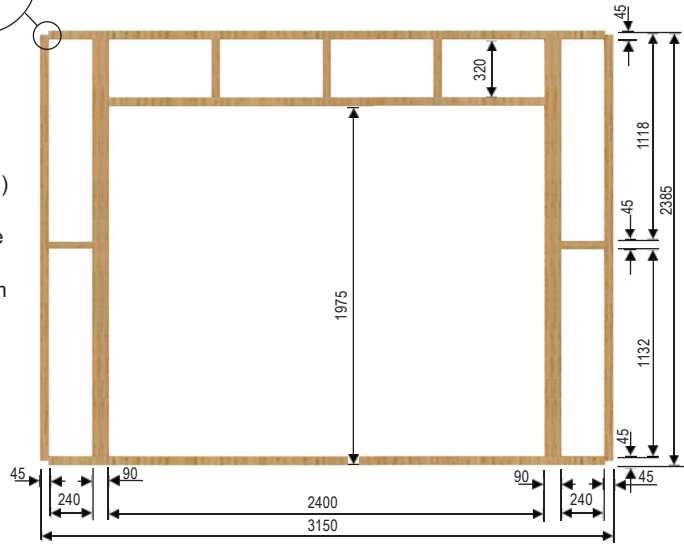

# TIMBER FRAME

- Select two 1000mm base plates (Green) and two 1000mm top plates (Red). With the front wall lying on the ground, nail plates to frame. Ensure Green joins to Green and Red joins to Red.

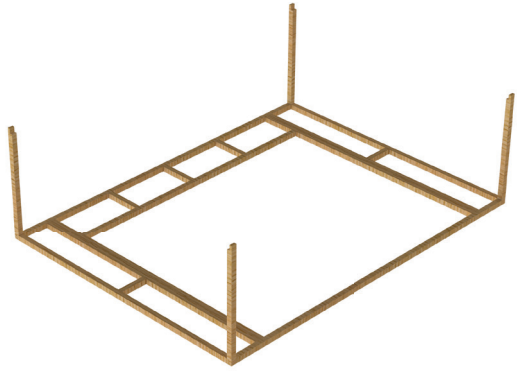



# TIMBER FRAME

- Position Back wall frame on top of plates. While someone supports frame, nail in place.

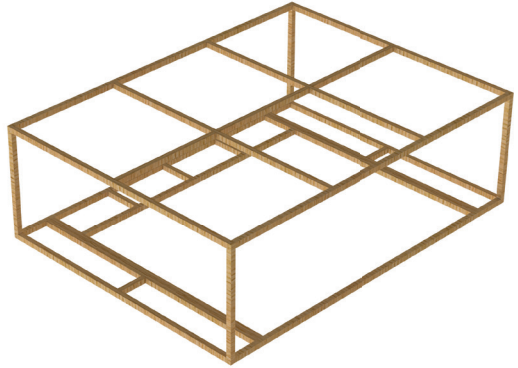

- Carefully roll frame over onto its base. (Pieces of timber from the packaging may be used to temporarily brace the frame before rolling it over). Position 910mm end wall nogs at correct height and nail in place.

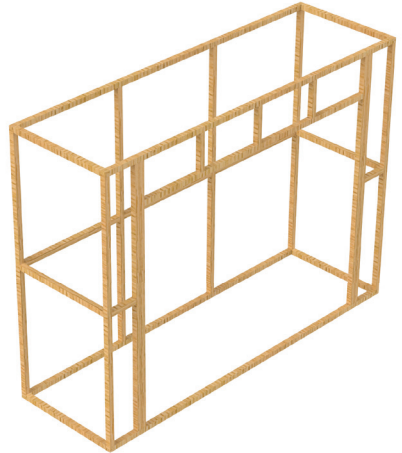

- The roof can slope either direction, either falling to the front or falling to the back. Determine which direction you want the roof to slope and using four 75mm nails, nail 45 x 45 H1 top plate packer to either front or back top plate to create the roof slope. (Note all instructions show roof sloping to the front)

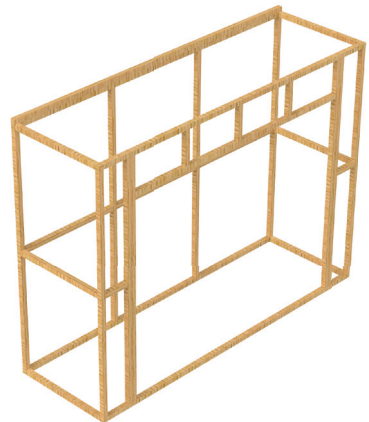

# SECURE FRAME TO CONCRETE BASE

- If your shed has a concrete base, position frame onto base. (Note: if access is an issue, you can position shed after the shed has been built but before you install the roller door).
- Ensure frame is straight and check that frame is square by ensuring diagonal measurements are the same.
- Screw base plate to floor using seven 100mm dyna bolts as shown.
- Using a hand saw, remove base plate between door studs by cutting flush with inside of door studs as shown.

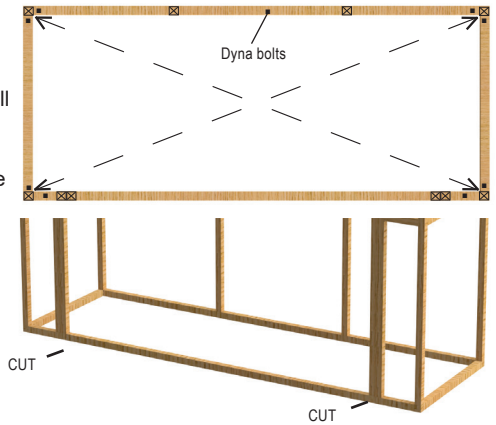

# OPTIONAL PLYWOOD FLOOR

- If your shed has an optional plywood floor, fit floor now.
- Using a hand saw, remove base plate between door studs by cutting flush with inside of door studs as shown.
- Using four 75mm screws, screw 3060mm floor joist to back of front base plate.
- Using twelve 75mm screws, screw 865mm floor joists as shown.

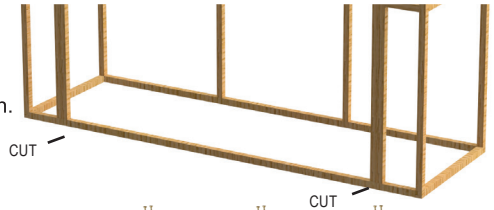

- Ensure frame is sitting level and check frame is square by ensuring diagonal measurements are the same.
- Place plywood sheets in position with cutouts facing towards the rear of the shed.
- Using thirty two 40mm screws, fasten the ply wood to the joists and base plates as shown.
- Using four 40mm screws, fasten the ply pieces between the door studs and corner studs.
- Attach door step flashing using three 30mm screws, screwing through top of flashing.

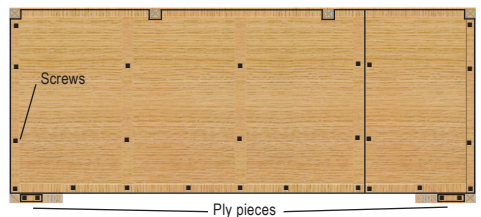
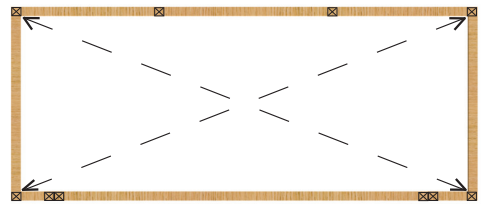
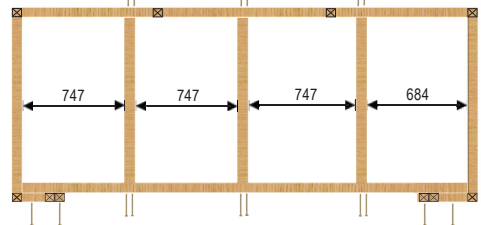

# ATTACHING DPC TO FRAME

- Any shed that is positioned on a concrete base should have the DPC attached to prevent water flowing between bottom plate and floor.
- Using approx twenty five 30mm clouts, nail DPC to bottom plate ensuring top is flush with top of base plate.
- Note if the shed doesnt have a concrete base, and is positioned directly on the ground, you wont need to attached DPC on the base plate.
- Using ten 30mm clouts, attach 75mm wide DPC membrane to each corner as shown. DPC should be level with top of top plate and botom of base plate.
- Repeat above, attaching DPC to door studs with the Top of DPC level with underside of lintel.

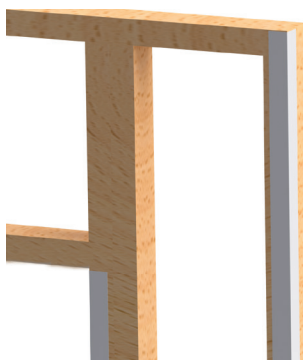
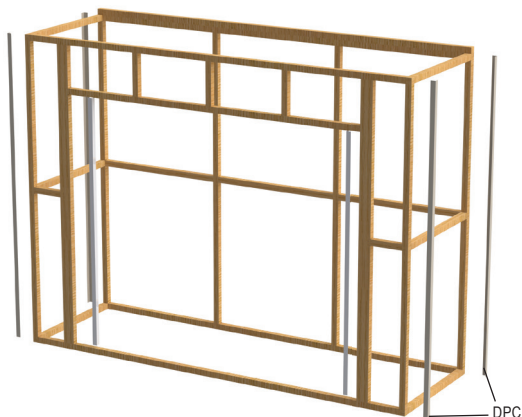
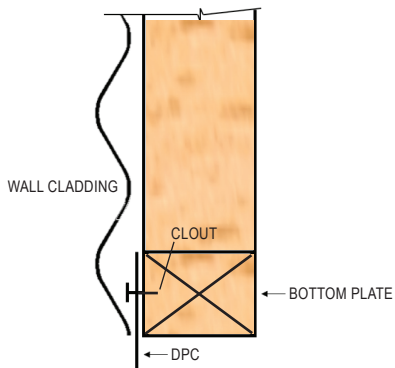

# ATTACHING DOOR HEAD FLASHING

- Using six 30mm clouts, nail door head flashing to underside and outside of lintel as shown.

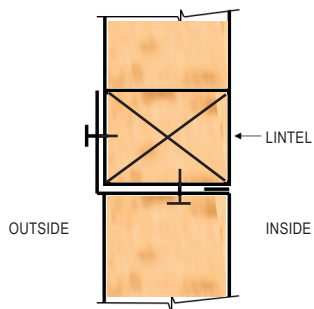

# WALL CLADDING

## TO AVOID CORROSION:

- Where at all possible try not to trap metal filings between two sheets. Remove all metal filings before riveting.
- Carbon in pencils reacts with the Zinc/ Aluminium coating on steel. Use ink to mark steel.

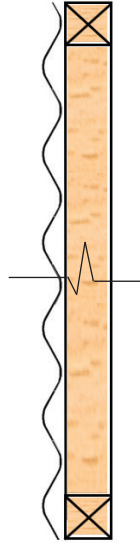

CLADDING DETAIL  
Side View

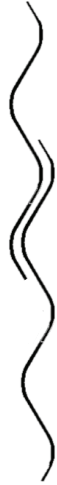

CLADDING DETAIL  
Overlap

## WALL CLADDING FIXING PATTERN

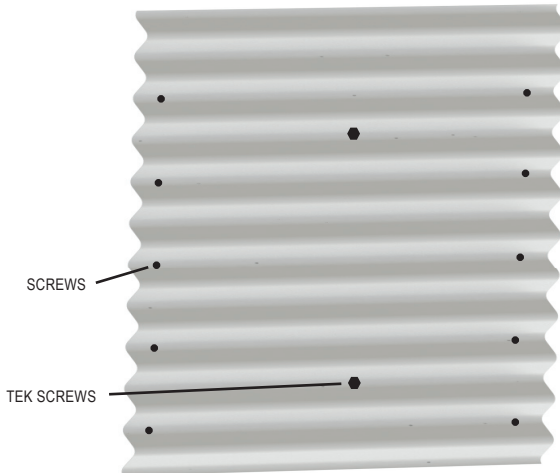

# WALL CLADDING - BACK & ENDS

- Note - When attaching wall cladding always ensure top sheet is level with top plate and ends of sheet are flush and parallel with studs. This will ensure that wall panels are square. (Always screw wall sheets through the trough of the profile)
- Position 1st sheet flush with top of top plate and both ends of sheet are flush with outside of studs.
- Using a 30mm screw, screw one end of sheet to frame. (Note - screw approx 30mm back from end of sheet. Corner flashing will cover screws when attached.)
- Repeat at the other end, ensuring top of sheet is flush with top of top plate.
- Screw sheet near the bottom, ensuring the ends of sheet are flush or parallel with stud.
- Position 2nd sheet underneath the first sheet, repeat above. Make sure the above sheet is always overlapped correctly.
- Using four 30mm screws, repeat above steps ensuring sheet is level and flush at each end.
- Position and screw bottom sheet using four 30mm screws.
- Using 25mm tek screws in the middle of the sheet, screw the three wall sheets off as per plan. (five screws per end of each sheet and four in the middle).
- Repeat above steps with each side wall.

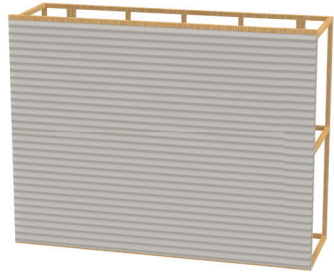
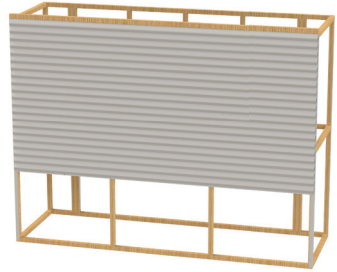
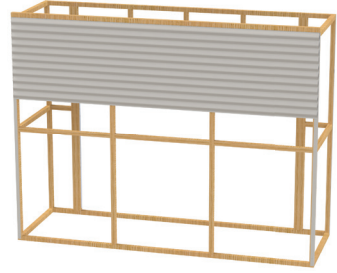

# WALL CLADDING - FRONT

- Position and screw sheet above doorway ensuring sheet is flush with top of top plate and both ends of sheet are flush with outside of studs. (Use three 30mm screws in each end and three screws along top plate and one 25mm tek screw in each 320mm stud)
- Fit remaining sheets each side of doorway and screw off as above.



# FLASHINGS

- Screw corner flashings onto each corner, using six 55mm tek screws per corner. Top screws should be approx 250mm down from top of top plate.
- Ensure corner flashings are square and parallel with walls panels.and top of flashings are level with top of top plate.

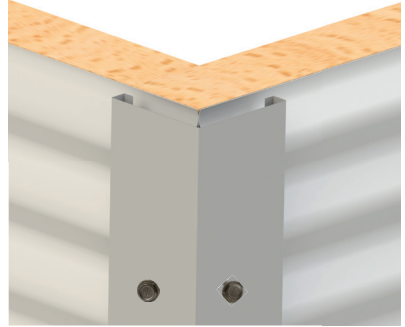

- Position door jamb flashing, so top is level with underside of lintel.
- Using tin snips, notch bottom of flashing around concrete or ply floor if required.
- Attach using three 30mm clouts, nailed to inside of stud and three 55mm tek screws, screwed through front wall cladding into stud.

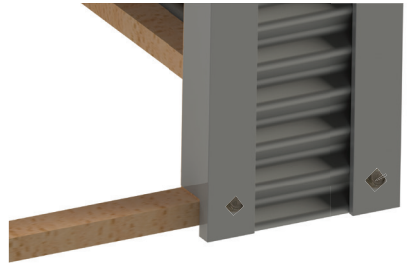

- Position door top flashing into position. (Note flashing length will protrude approx 10mm past outside edge of each door jamb flashing).
- Using three 55mm tek screws,(one each end and one in middle) screw flashing to lintel.



# SPOUTING

- If shed has an optional downpipe kit, fit end caps now.

- Using six rivets per end, fit and rivet end caps to each end of spouting and silicone end caps to ensure there are no leaks.

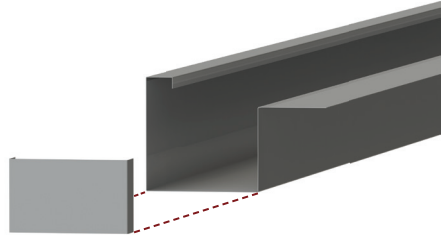

- Nail assembled spouting to top of top plate, using four 30mm clouts as shown. (Note - spouting will overhang corner flashing by approx 20mm, spouting will always be on the lower top plate.)



- Determine position of downpipe and mark a 30mm diameter hole in underside of spouting. (Note - hole needs to be centrally above corner flashing and can be at either end.)

- Mark a 30mm diameter hole ensuring hole is as close as possible towards the corner flashing to allow enough clearance for downpipe cover flashing.

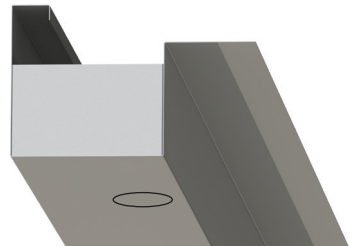

- Cut out hole by drilling a few small holes then using tin snips to enlarge hole to correct size.

- Fit dropper through hole and tighten nut on dropper. Silicone around top of dropper. Attach the hose to dropper with hose clip.



- Position downpipe cover flashing over hose and rivet to wall cladding.



# ROOF

- If an optional clear roof sheet has been supplied, this can be fitted in any of the middle positions. (Note - both edges of clear roof sheet overlap standard sheets at each side.)
- Position first roof sheet into position ensuring sheet will correctly overlap the next sheet. Edge of sheet will be 5mm in from outside edge of timber frame.



- Position sheet 15mm past top plate (as shown) so that sheet overlaps rear spouting as shown.
- Using one 55mm tek screw, screw roof sheet to lower top plate. Ensure roofing screw is screwed through the top of the crest on corrugate profile. (See roof fixing pattern below)
- Repeat using one 50mm clout, predrill and nail roof sheet to upper top plate through rib of corrugate, ensuring edge of sheet is 10mm in from the timber frame.

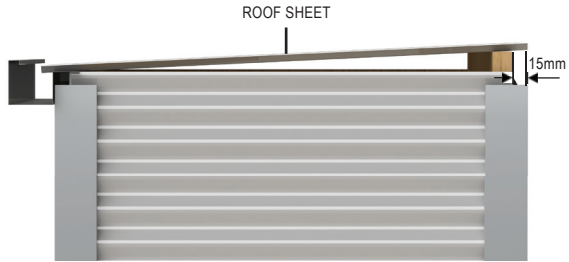

(Note: Use tek screws on lower edge of roof sheets and 50mm clouts on upper edge as this is covered by ridge flashing)

- Check that top plates are straight, before screwing and nailing remaining sheets.
- Position remaining sheets, using just one screw and one clout per sheet, until all sheets are in place.
- Screw and nail off all sheets as shown, using four screws and four clouts per sheet per top plate.



## ROOF FIXING PATTERN





# RIDGE & BARGE

- Position ridge flashing into position ensuring soft edge is on top. Note ridge will overhang corner flashing by approx 20mm.
- Using twelve rivets (3 per sheet), rivet ridge to the ribs on roof sheets.
- Using two rivets, rivet ridge to corner flashing.
- Push soft edge down into roof corrugations to prevent water penetrating under the ridge flashing.



- Position barges as shown, using six rivets, rivet barge to ridge and spouting.
- Rivet underside of barge to underside of spouting.

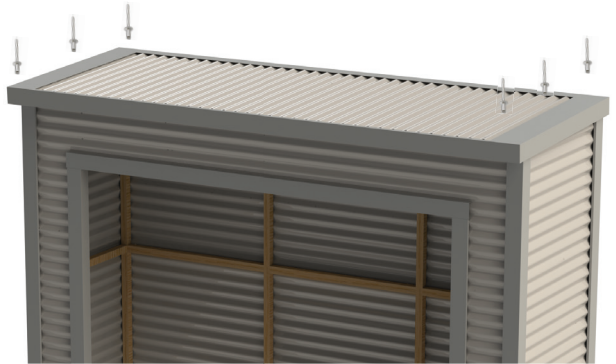

- Using tinsnips, cut the side of the barge flashing flush with ridge flashing.

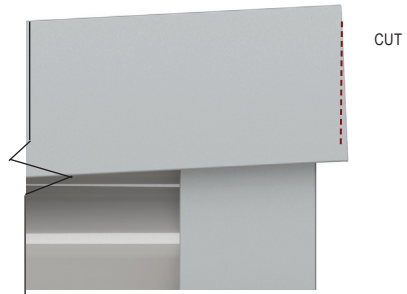

# ROLLER DOOR

## BEFORE YOU BEGIN

- This Roll-A-Door is designed and tested to provide security, attractive appearance and smooth, low effort operation provided it is installed and operated in strict accordance with the following safety warnings. Failure to comply with the following instructions may result in death, serious personal injury or property damage.
- NOTE:** Do not unwrap packaging around roller door until requested, as this will intension the door.

## SERIES 1 ROLL-A-DOOR

DESCRIPTION	ITEM	QTY	PACKED	CHECKED
Rolled plastic wrapped door	A	1	<input type="checkbox"/>	<input type="checkbox"/>
"A" Style brackets, left & right hand side	B	2	<input type="checkbox"/>	<input type="checkbox"/>
Door guides, left & right hand side	C	2	<input type="checkbox"/>	<input type="checkbox"/>
Steel locking bars	D	2	<input type="checkbox"/>	<input type="checkbox"/>
<b>SMALL PARTS BAG CONTAINING:</b>				
Guide clips (door size dependent)	E	4-10	<input type="checkbox"/>	<input type="checkbox"/>
Door handle and fixing to suit	F	1	<input type="checkbox"/>	<input type="checkbox"/>
Bottom rail stops and 6mm screws	G	2	<input type="checkbox"/>	<input type="checkbox"/>
Faceplate and lock assembly (2 keys)	H	1	<input type="checkbox"/>	<input type="checkbox"/>
Locking bar retainer	I	2	<input type="checkbox"/>	<input type="checkbox"/>
Locking bar covers	J	2	<input type="checkbox"/>	<input type="checkbox"/>
"U"Bolts	K	2	<input type="checkbox"/>	<input type="checkbox"/>
Axel / bracket saddles	L	2	<input type="checkbox"/>	<input type="checkbox"/>
8mm nuts for "U" bolts	M	4	<input type="checkbox"/>	<input type="checkbox"/>
Counter sunk screws for lock and fascia	N	2	<input type="checkbox"/>	<input type="checkbox"/>
7mm x 4mm mushroom head screws for locking bar	O	2	<input type="checkbox"/>	<input type="checkbox"/>
4mm x 6mm screws for handle	P	2	<input type="checkbox"/>	<input type="checkbox"/>
10mm washers	Q	4	<input type="checkbox"/>	<input type="checkbox"/>
8mm washers (door size dependent)	R	8-12	<input type="checkbox"/>	<input type="checkbox"/>

## TOOLS

- A professional installers tool kit is required to install the door. You will need assistance to help you lift the door up safely and carry out some other steps. A Soft Wood Chock will help hold the door until the guides and stops are fitted. Prepare a 400mm long Wood Chock as per diagram.



Wood chock

# ROLLER DOOR

## PARTS CHECKLIST

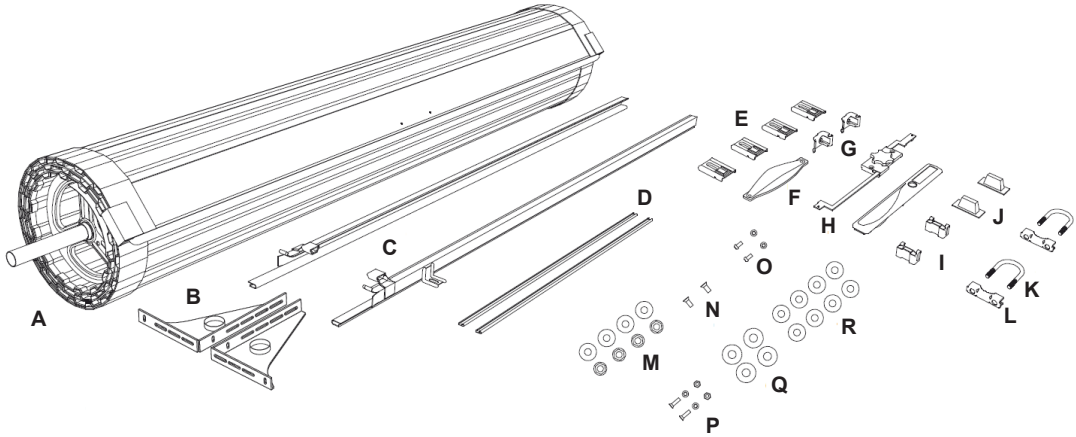

## REQUIREMENTS BEFORE INSTALLATION

- **Level and plumb** - The door must be installed in an absolutely level position, if opening is not level and square, appearance and/or sideroom requirements will be affected. The floor should be level or recessed across the opening to avoid gaps.

## MEASUREMENTS

- **Opening width** - As the standard door overlaps each side by 30mm or more, the door should be 60mm wider than the 2400mm opening.
- **Opening height** - The door opening height (or drive through clearance) indicates the distance between the ground and rubber seal at the bottom of the door, with door fully open. For doors with a handle, the bottom rail is recommended to hang a minimum of 80mm below the lintel.

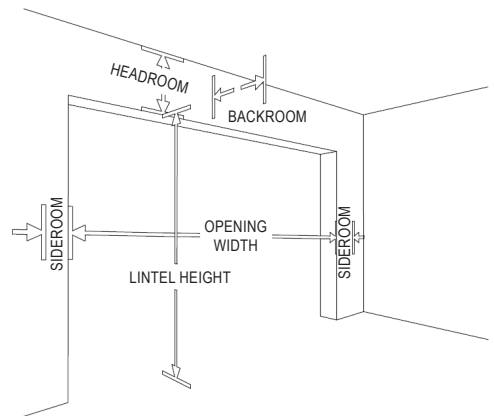

# ROLLER DOOR

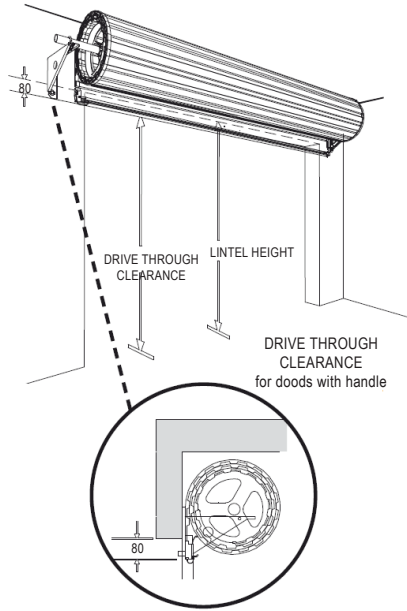

## HEADROOM REQUIREMENTS FOR DOORS

- **Headroom** - A minimum of 410mm of headroom is required. If the door is installed lower into the opening than shown below, additional loss of door opening height will result.

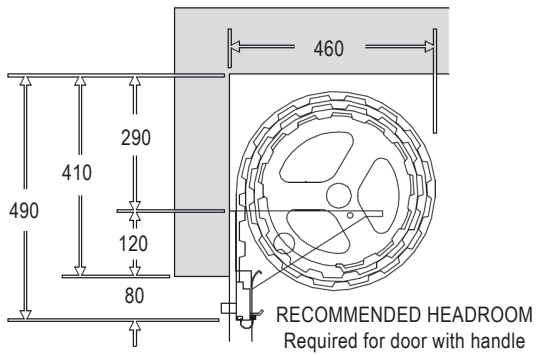

# ROLLER DOOR

## INSTALL FIRST BRACKET

- Measure the door curtain width and mark where edge of curtain will be, allowing for over lap on each side of the opening.
- Add clearance of 20-30mm from edge of curtain to inside edge of bracket to determine positioning of the bracket.
- Headroom. Measure up 120mm from underside of the lintel.
- Mark two hole positions using top and bottom slots on the bracket.
- Drill both holes, then attach bracket using the 50mm x 10mm coach screws and washers supplied.

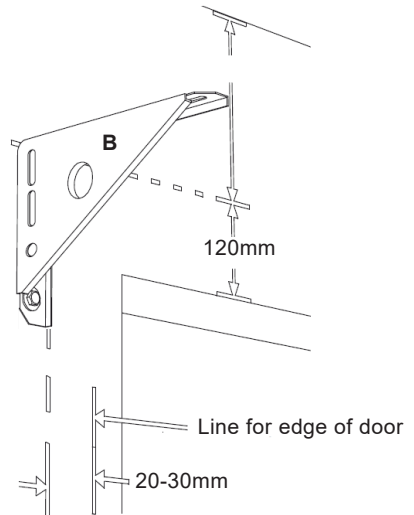

## INSTALL SECOND BRACKET

- Using a water level or level /straight edge mark the position for the second bracket
- Re-check levels then drill and fix as with first bracket.



**CAUTION:** The brackets must be perfectly level for the door to operate.

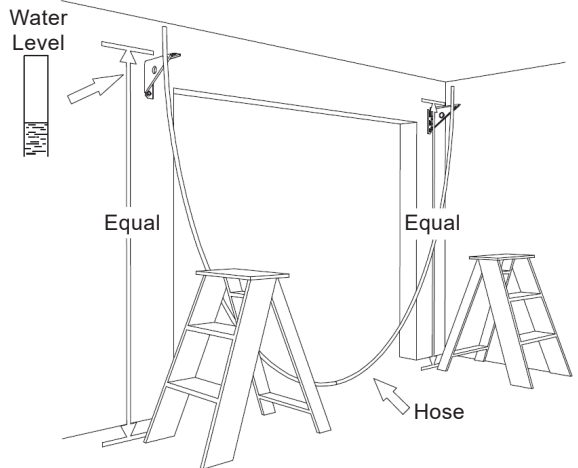

## PLACE DOOR ON BRACKET

- Do not cut plastic or packaging yet.
- Using two persons and correct lifting techniques, lift door onto the brackets (the right way round so that the door will roll down from the front of the opening).
- Immediately loosely fit the "U" bolts (K) , saddles (L) , washers and nuts (M) to the brackets in position shown. Fitting the 'U' bolts eliminates the door falling from the brackets. (Do not tighten yet)

# ROLLER DOOR

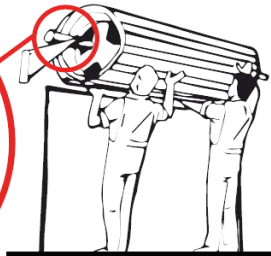
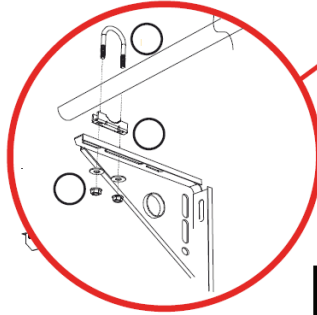
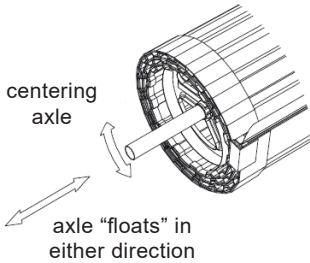

**WARNING!** practice correct lifting techniques

## POSITION DOOR

- Centre the door with the opening, while ensuring the floating axle is also centred with the door. Do this by lining up previous marks with the hub, then lift both the axle and the door together until it is centred with the opening.
- Rotate the curtain and axle so that the bottom rail of the door is positioned as shown (3 o'clock).
- Push the axle forward in the slots (toward the opening) and tighten the nuts firmly without overtightening.

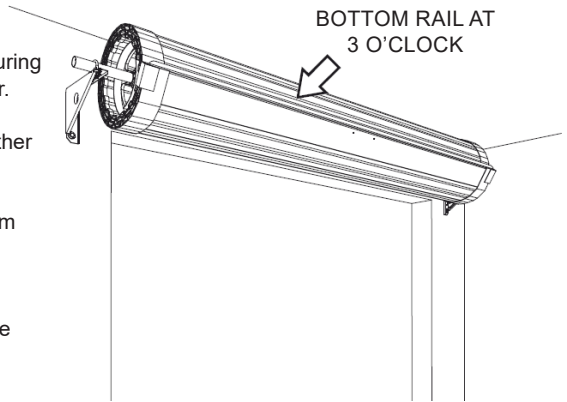

## TENSION THE SPRINGS

- Ensure that the bottom rail is at the 3 o'clock position as shown.
- Ensure both "U" bolts are tightened, then rotate door  $1\frac{1}{2}$  turns in a forward direction to apply tension.
- Do not let go as the springs are now tensioned. See arrow in image.
- Hold the door firmly, NOW cut the plastic wrap along the bottom rail (taking care not to damage door surface or weatherseal).
- Pull the curtain down slowly and carefully position the wooden chock (or other appropriate stop) as shown. Take care not to damage door surface.

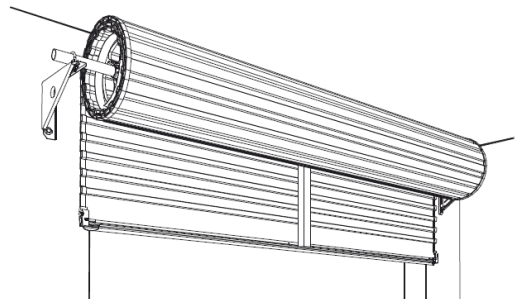
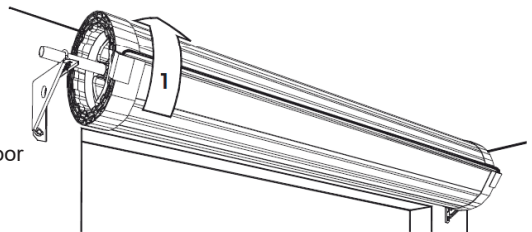

Chock will hold the door until the guides and stops are fitted.

# ROLLER DOOR

## ATTACHING STOP

To attach bottom rail stops (G) to bottom rail of door.

- Hook stop behind lip in rail, as shown.
- Secure from underneath the rail with screws (G) supplied. Trim the weatherseal flush with the end of the bottom rail.

## GUIDES

- Check that curtain overlaps equally on both sides, and cut the guides (C) to the correct length that is, level with the brackets (B)

**tip** To prevent clips from sliding down the guide, temporarily secure them with adhesive tape.

- Slide four guide clips (E) into each guide (C). Position the bottom clip 200mm from the floor with the rest evenly spaced along the guide.
- Position one guide over the edge of the door curtain. Mark and drill the top fixed guide clip and secure using 40mm x 8mm coach screw and washer, allowing 3mm clearance between inside of guide and plastic Roll-A-Guide. Ensuring guide is plumb, fix remaining clips. Repeat with 2nd guide.
- Remove the wooden chock and slowly lower the door removing plastic wrap as you pull door down, reposition the guides as necessary to allow smooth and even operation with 0>1mm clearancet.
- Ensure door curtain enters guides smoothly. It will be necessary to adjust the guide lead in to achieve this.

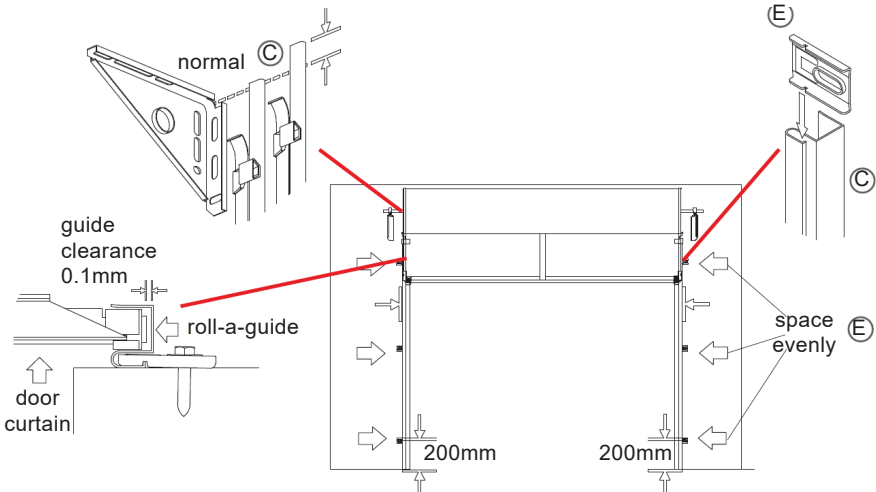
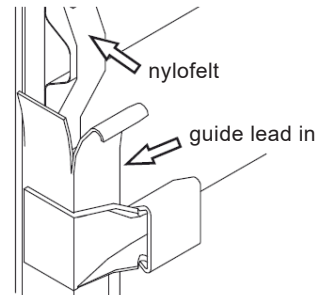
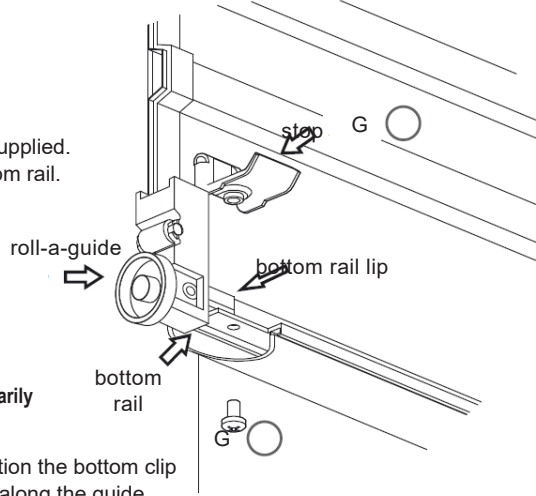

# ROLLER DOOR

## FITTING HANDLE

- Fit the handle (F) to the outside of the door using the screws (P), nuts and washers provided

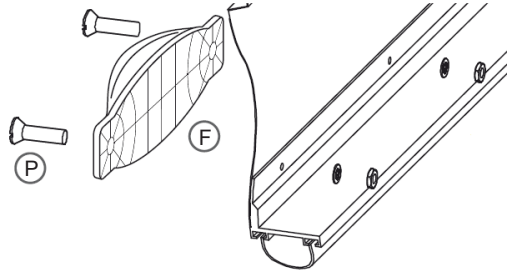

## CENTRE LIFT LOCK



**LACERATION:** Wear appropriate gloves as some edges of the door are very sharp.

- Raise the curtain until the lock corrugation is visible above the door guides.
- Install locking bar retainer (I) in line with lock corrugation by pushing retainer towards door edge, sliding the legs under the Nylofelt® and hooking them over the curtain edge. Ensure lock bar retainers sit squarely on door curtain

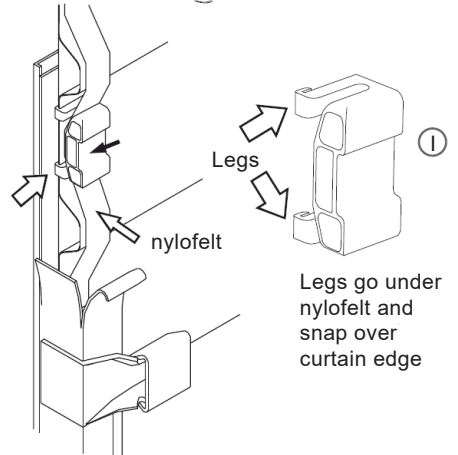

**It is easier to hook legs one at a time.**

- Fit faceplate (H) to outside of door where the hook will latch onto curtain edge, then slide faceplate as far to the right as possible. Use adhesive tape on outside to hold in position
- Attach the lock body (H) to the faceplate from the inside, using the mounting screws and washers. Do not over tighten the screws.

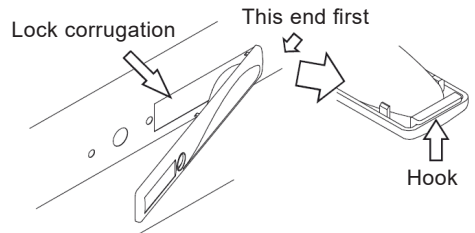

- With the door in the closed position slide the end of the locking bars through the locking bar retainers, and while holding the bars level mark the side of the guides.
- Drill and file out a rectangular slot no longer than 25mm and no wider than 10mm. Ensure top of slot remains in line with top of locking bar.
- Slide bars through the guide slot, then back onto lock arms. Screw on securely using the counter sunk screws (O). Ensure that locking bars do not protrude more than 20mm beyond guide when engaged in locked position. It may be necessary to adjust the length of the bars.
- Ensure a clean and dry guide surface. Wipe guide with clean rag.
- Peel lining from lock bar cover (J) and position over hole. Check the movement of locking bar is free.



# ROLLER DOOR

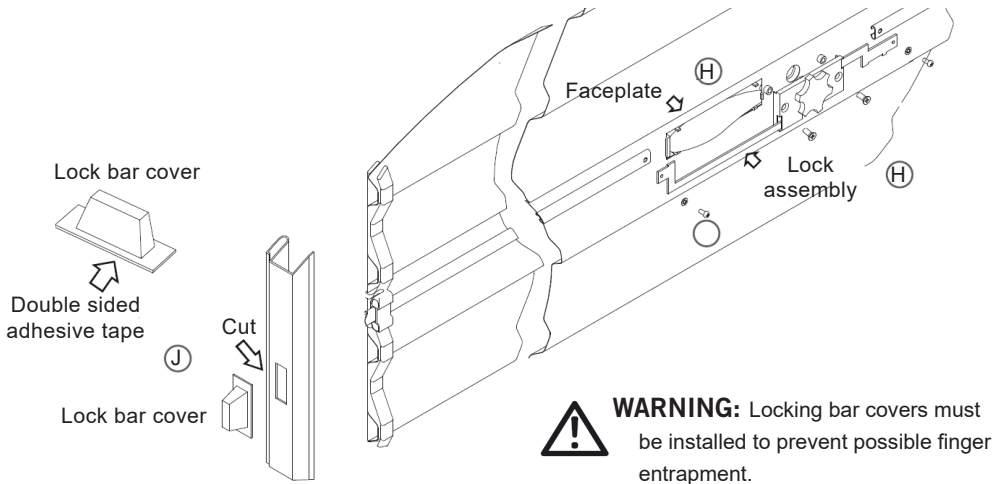

# CLEAN UP

- Remove all swarf (drill filings) with a soft brush or rag.
- Hose down roof and walls thoroughly.
- For Coloursteel sheds use touch-up paint provided on all nail heads, rivets and exposed cuts.

# ROLLER DOOR

## TROUBLESHOOTING

SYMPTOM	POSSIBLE CAUSE	REMEDY
Door is hard to operate in ANY DIRECTION	Door jamming in the guides	Check: a) the guide clearances b) the guides are plumb c) that the guide surfaces are clean and free from oil d) that the locking bars are the correct length e) that the weatherseal is correct length
The door is hard to operate in ONE DIRECTION	The spring tension requires adjustment	a) If the door is hard to lift, but tends to drop, refer to section "centralise the axel when door is mounted" to increase the spring tension b) If the door is hard to close, but tends to rise, refer to section "centralise the axel when door is mounted" to decrease the spring tension
If the door rolls up crooked	Brackets are not level	Make sure brackets are level, refer to section "install second bracket".
	Guides are not plumb	Make sure the guides are plumb, refer to section "guides".
	Axle is not centred	Centralise the axle, refer to section "centralise the axel when door is mounted"

## CENTRALISE THE AXEL WHEN DOOR IS MOUNTED



**WARNING:** Ensure that pipe wrench is fitted correctly to the axle and if it is gripped onto the axle do not underestimate the tension in the spring when undoing the clamps.

**CAUTION:** THIS ADJUSTMENT REQUIRES 2 PERSONS TO COMPLETE.

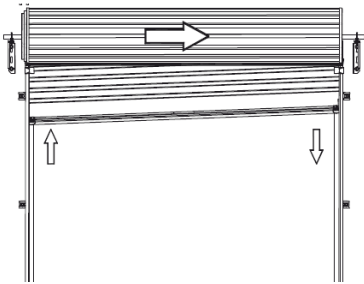

If the door rolls up crooked with the RIGHT HAND SIDE higher than the left proceed as follows:

- Roll the door up as high as possible and tie two ropes around the door roll approximately 300mm from each end, as a safety precaution.
- With a person at each end of the door, hold the axle firmly with a large pip wrench (Stillson) at least 450mm long.
- Loosen the "U" bolt nuts at both ends and KEEP A FIRM GRIP ON WRENCH.
- Move the axle to the RIGHT between 20 - 40mm.
- Re-tighten "U" bolts before releasing pipe wrench.
- Test and repeat if further adjustment is needed.
- If the door is stiff to work or rattles over lead-in on top of guide, then refer to Section "Position door"

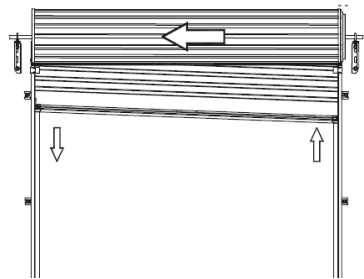

If the door rolls up crooked with the LEFT HAND SIDE higher than the left proceed as follows:

- Roll the door up as high as possible and tie two ropes around the door roll approximately 300mm from each end, as a safety precaution.
- With a person at each end of the door, hold the axle firmly with a large pip wrench (Stillson) at least 450mm long.
- Loosen the "U" bolt nuts at both ends and KEEP A FIRM GRIP ON WRENCH.
- Move the axle to the LEFT between 20 - 40mm.
- Re-tighten "U" bolts before releasing pipe wrench.
- Test and repeat if further adjustment is needed.
- If the door is stiff to work or rattles over lead-in on top of guide, then refer to Section "Position door"

# ROLLER DOOR

## ADJUST TO SPRING TENSION



**WARNING:** Ensure that pipe wrench is fitted correctly to the axle and if it is gripped onto the axle do not underestimate the tension in the spring when undoing the clamps.

**CAUTION:** THIS ADJUSTMENT REQUIRES 2 PERSONS TO COMPLETE.

- a) With the door rolled up tie two ropes around the door roll approximately 300mm from each end, as a safety precaution.
- b) With a person at each end of the door, hold the axle firmly with a large pipe wrench (Stillson) at least 450mm long.
- c) Loosen the "U" bolt nuts at both ends and KEEP A FIRM GRIP ON WRENCH.
- d) Rotate the axle in the required direction (see diagram).
- e) Re-tighten the "U" bolts BEFORE releasing pipe wrench.
- f) Test and repeat if further adjustment is necessary.

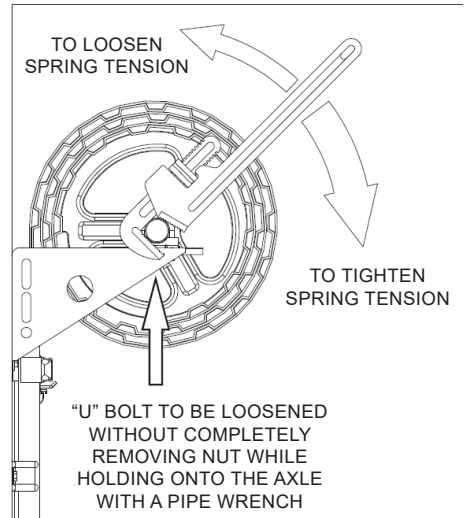

## AFTER INSTALLATION CARE

General care of your Roll-A-Door

### **Cleaning**

**BLUESCOPE COLORBOND® FINISH** Your B&D Roll-A-Door® door has been pre-painted with a silicone modified polyester formulation, which is one of the best paint films commercially available today. However, all exposed surfaces require some attention to guard against the premature onset of corrosion and any other harmful atmospheric effects. In our atmosphere there are harmful deposits that gather on the door surface and if not removed regularly, will seriously affect the appearance and life of the door.

Washing of the door with clean water and a cloth every 14 days is recommended – particular care should be taken to clean areas of the door not normally washed by rain, including the top of the door roll inside the garage.

**NOTE:** In locations where there is likely to be salt in the air or industrial fallout is severe, more frequent washing is advisable and additional protection of the surface maybe required.

Touch-up paint, if required, is available from your B&D dealer.

### **Lock**

Your lock does not require special maintenance, however, if the keyway becomes stiff, the application of powdered graphite is recommended – do not grease or oil the lock. The faceplate should be washed with soapy water and rinsed well. Strong solvents, such as acetone, should not be used – these will damage the surface. **WARNING!** Do not disassemble the lock mechanism.

When opening the door, always make sure the key is with drawn from the lock – if this is not done, the lock mechanism could be damaged and the key bent or broken.

# ROLLER DOOR

We suggest you record your full Key letter and Number on the front of this manual and if replacement keys are required they can be obtained from your nearest B&D office, simply by quoting this number. If the keys have been lost and the number not recorded, it can be found stamped into the locking arm at the back of the mechanism.

**NYLOFELT®** On no account should you use grease or oil in the door guides or on the Nylofelt® running strips – the grease or oil will clog the Nylofelt® and spoil the operation of the door. An occasional wipe with a cloth dampened with mineral turps or methylated spirits, down the inside of each guide, is very beneficial in removing any trace of grease or dirt.

After the guides have been cleaned, a silicon spray may be used in the guides.

NOTE: WD40 or similar oil based sprays are not silicon and should not be used.

Care should be taken not to damage the Nylofelt®, however, if Nylofelt® is cut or damaged, a lighted match should be used to quickly seal the ends of the nylon braiding, so as to stop any further deterioration.

## Regular maintenance required

B&D recommends that you check the operation of your Roll-A-Door® at least every six months (more regularly in extreme environments or frequent use). The effort required to manually open and to manually close the door should be about the same (if door has an automatic opener, put into manual mode before testing door). If the door is difficult to operate in either direction (up or down) then check:

- 1) that the Nylofelt® running strips on each side of the door have not slipped from the edge and are jamming the door;
- 2) that the door is running correctly in the guides and the guides are straight and perpendicular; and
- 3) that the inside surfaces of the guides are clean and free of obstructions. (see paragraph on care of Nylofelt®)

If you have checked these (and corrected where necessary) and the door is still difficult to operate, then your door will need a service to adjust the spring tension and possibly other operational parts of the door. This service should only be carried out by an experienced door technician, using the correct tools.

If you have an automatic opener fitted to your door, it is particularly important that you ensure the optimum operation of the door, otherwise you may reduce the effective life of the opener.

To keep your door running well, it is recommended that your door be serviced, by an experienced door technician, every 12 months (more regularly in extreme environments or frequent use), or earlier if required.

## Spring tension

It is natural for springs to lose tension over time. When spring tension is adjusted or when your door is first installed it is usual to apply a little more tension than is required for balanced operation, to allow for the normal “settling in” of the springs.



## DURATUF PREMIUM SHED WARRANTY

### GUARANTEE TO CUSTOMER

Congratulations on purchasing a Duratuf Storage Shed. With proper care and attention, this product will last any years. For your benefit **PLEASE READ THE FOLLOWING INFORMATION CAREFULLY.**

### WARRANTY ON METAL CLADDING

Riverlea Group Ltd guarantee that the metal roofing and wall cladding on Kiwi and Fortress Garden Sheds may be used in moderate and inland corrosion zones or areas where the first year mild steel corrosion rate is less than 200g/m<sup>2</sup>, and that in these conditions, they will not perforate due to corrosion within 18 years of date of manufacture.

### TERMS AND CONDITIONS

1. Damage or corrosion due to the following circumstances is not covered by this warranty.
  - Mechanical, chemical or other damage sustained during or after installation.  
**NOTE:** Clean swarf off shed **IMMEDIATELY** after assembly  
Do **NOT** mark cladding with pencil  
Do **NOT** allow manures, chemicals or other corrosive materials to have direct contact with cladding
  - Force majeure or other causes beyond the control of Riverlea Group Ltd.
2. This warranty does not cover material installed in severe and very severe environmental situations, or in any area where the mild steel corrosion rate (as published by BRANZ) exceeds 200g/m<sup>2</sup>.
3. Minimum maintenance must be carried out in accordance with instructions below.

Should the cladding fail to perform as specified above, the liability of Riverlea Group Ltd shall in all cases be limited to replacing or repairing the defective product. The balance of the original warranty will cover any repaired or replaced material. Riverlea Group Ltd will not be liable for any consequential loss or damage, labour or transport charges. All claims made in writing within 21 days of discovery, quoting the reference number at the top right hand corner of this page.

### MAINTENANCE

Following are the minimum maintenance requirements for cladding used in Kiwi Garden Sheds and Fortress Sheds.

- Washing all surfaces by rain, and annual hosing of sheltered areas using a hose and soft nylon brush.
- Within 2km of coast—wash every 3 months as above. After a storm, wash the cladding and the gutters as soon as possible to remove any highly corrosive salt deposits.
- Volcanic Ash Fallout—wash as soon as possible, removing fallout from roof and gutters.
- Gutters to be kept clean of leaves and dirt.

Should you require additional technical information please contact us at the details below.

## WARRANTY REGISTRATION

Please visit <http://www.riverleagroup.co.nz/warranty-garden-sheds> to validate the Warranty on your shed.

Click on the Warranty Registration Link and complete all details.

If you are unable to access the computer, please phone us on 0800 438 274 and one of the customer services team will help you to activate the warranty on your garden shed.

Many thanks, from the Team at Riverlea Group.