

CADET PLUS

ELEMENTi

BY ROBERTSON NZ LTD

BTW CC TOILET SUITE

CODE: 15044.10

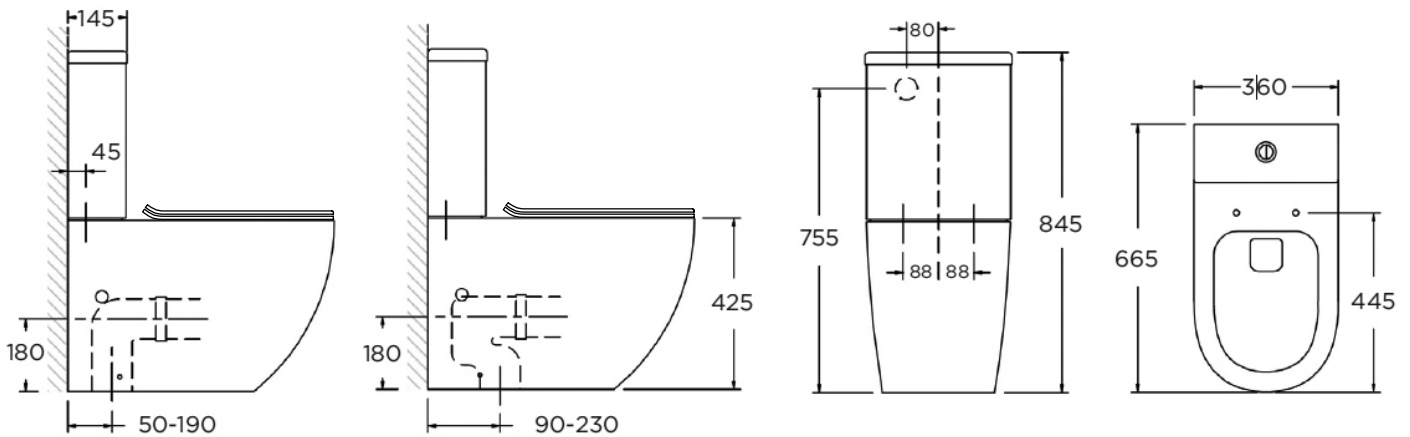

NOTE: This set out is achievable using optional pan convertor (Sold separately - Code: 15019.10)

FEATURES	
Recommended use:	Domestic, hotel and commercial
Material:	Vitreous China
Weight Pan:	37kg
Cistern:	16kg
Fixing:	Toilet pan screwed and silconed to floor. Cistern bolted directly to pan.
Warranty:	Refer to website www.robertson.co.nz
SPECIFICATIONS	
Colour Availability:	White
Rim Configuration:	Rimless
Bowl Configuration:	P trap (converts to S using plastic S-bend provided)
P Trap Set Out:	180 mm
S Trap Set Out:	50-190 Pan Convertor = 90-230 mm
Pan Fixing:	Toilet pan screwed and silconed to floor. Cistern bolted directly to pan.
Cistern Fixing:	Bolted directly to pan.
Seat:	Supplied with soft close seat.
Water Inlet:	Bottom and back inlet
Cistern:	4.5 / 3 litre dual flush
Inlet Valve:	Rec. max operating pressure as per AS3500.1, clause 3.34 is 500 Kpa.
WELS:	4 Star, 3.3 litre per average flush



PRIOR TO INSTALLATION

IMPORTANT:

Please inspect your new toilet suite before installation to ensure no damage has occurred during transit. If damage has occurred, or visible defects exist, do not proceed with installation and advise retailer immediately. No claims will be accepted after installation has commenced.

It is recommended that toilet seat and cover be installed after all trades are finished. All measurements for roughing-in should be taken from finished wall/floor.

Robertson recommends a qualified trade person fit your Toilet Suite.

Please note, Robertson will not be liable for the cost of installation or removal of the Toilet and the warranty will be voided if damage occurred during or after installation.

A - PAN INSTALLATION

- 1 Place the toilet pan into position ensuring that the outlet is suitable to be connected to the pan collar or vario bend.

To calculate the vario bend cutting distance, measure from the rear of the pan to the start of the ceramic spigot, add 30mm to this distance and use that dimension to trim the length of the installed vario bend.

- 2 Mark and measure where the pan to floor fastening brackets are required (refer Image A).

If there is a wet seal floor membrane that you need to avoid puncturing with the pan to floor fixing kit, do not drill the floor and go to step 4.

- 3 Remove the toilet pan and drill the holes in the floor to fasten the supplied brackets. Check the pan fits.

- 4 Apply a bead of silicon sealant to the underside rim of pan. Re-position over the pan collar/ trimmed vario bend and fix pan with screws and covers (do not overtighten).

Image A

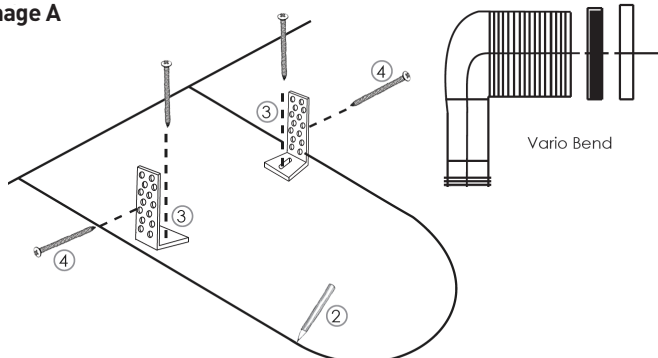

B - CISTERN INSTALLATION

- 1 Check that top fixing bolt assemblies are installed in the pan.
- 2 Ensure all fittings are fully tightened into cistern.
- 3 Position the cistern seal over the nut on the outlet valve on the underside of the cistern (refer Image B).
- 4 Lift the cistern onto the pan, lining up cistern with the assemblies in the pan.
- 5 Using the bolts provided tighten the cistern to the pan evenly but do not overtighten.
- 6 Connect the cistern to a stop tap using the appropriate plumbing fittings.
- 7 Ensure that the inlet water pressure does not exceed 500 KPA as per AS/NZS3500 3.3.2.

Image B

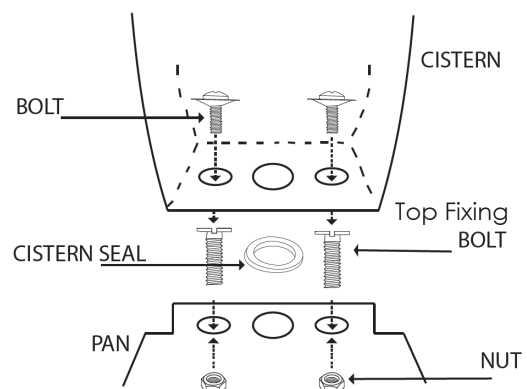

SEAT INSTALLATION

Install the seat with the manufacturers instructions provided. We suggest that the toilet seat installation is left until all trades are finished.

Dear Customer,

This is the warranty by Robertson relating to this product. Please keep it together with your purchase receipt. In the unlikely event of a query please contact your nearest supplier.

WARRANTY

You have purchased a quality product from Robertson. This products is covered by a 5 year warranty for sanitary ware and a 1 year for spare parts. This warranty covers faults in the product construction, material and assembly. Faulty products will be repaired or exchanged free of charge. Faulty items become our property.

Where the product falls within the warranty period we offer a free replacement part (or nearest equivalent). This warranty does not include the cost of labour to remove or install any product.

If this product is no longer available an equivalent alternative will be provided.

This warranty does not include faults caused by:

- Unsuitable or improper use
- Incorrect installation
- Installation or part installation by the purchaser or any person other than a LICENSED PLUMBER or tradesman
- Normal wear and tear
- Inadequate or complete lack of maintenance
- Chemical, electrochemical or electrical influences.

SPARE PARTS

Spare parts (includes the toilet seat) which are within 1 year from the date of purchase found upon inspection by an authorised Robertson representative to be defective in construction, material or assembly, will be replaced free of charge.

CLEANING RECOMMENDATIONS

Elementi sanitary ware should not be cleaned with abrasive materials eg. steel wool / abrasive. Do not use any corrosive or abrasive cleaning agents containing acids or scouring agents.

Bleaches can also discolour seats and hinges and therefore should not be used. If your toilet has metal hinges they should only be cleaned with a mild liquid domestic cleaner, with soft soapsuds.

After cleaning, rinse with clean water and polish with a clean soft cloth.

In the event of a warranty claim, we will replace or repair defective products, or pay for the cost of having defective products repaired or replaced, but will not be liable for any injury to any person, damage to any property, any indirect or consequential loss, or in any other respect.

DEAR PLUMBER...

Could you please ensure a copy of the installation instructions is left with end user for future reference.

Distributed by

robertson[®]
BATHWARE
— SINCE 1987 —

PH: +64 (0)9 573 0490

FAX: +64 (0)9 573 0495

EMAIL: sales@robertson.co.nz

ROBERTSON.CO.NZ