

Installation Manual

Content

1	INTRODUCTION	2
2	SAFE WORKING PRACTICES	6
	2.1 Stay healthy when working with building products containing crystalline silica	6
	2.2 Avoid breathing in crystalline silica dust	6
	2.3 Storage and delivery	7
	2.4 Tips for safe and easy handling	7
3	APPLICATIONS	8
	3.1 James Hardie Rigid Air Barrier	8
	3.2 Stud to top plate fixing	8
	3.3 Seismic deflections	8
4	FRAMING AND FIXINGS	9
	4.1 Framing	9
	4.2 Fixings	9
	4.3 Fastener durability	9
	4.4 Clearances	10
5	INSTALLATION	11
	5.1 Board layout	11
	5.2 Stud to top plate fixing	16
	5.3 Flashings	18
6	BRACING	27
	6.1 Bottom Plate Fixing/Hold down restraints	27
	6.2 Fastener Durability and Size	27
	6.3 Sheet Nailing	27
	6.4 Sheet Orientation	27
	6.5 Service Penetrations	27
7	PRODUCT INFORMATION	37
	7.1 General	37
	7.2 Durability	37
	7.3 Alpine regions	37
8	FINISHES AND MAINTENANCE	37
	PRODUCT WARRANTY	39

WE VALUE YOUR FEEDBACK

To continue with the development of our products and systems, we value your input. Please send any suggestions, including your name, contact details, and relevant sketches to:

Ask James Hardie™
literaturefeedback@jameshardie.co.nz

1 Introduction

James Hardie manufactures a range of rigid air barriers such as HomeRAB™ Pre-Cladding and RAB™ Board.

1.1 HomeRAB Pre-Cladding is a 4.5mm thick fibre cement sheet which is sealed on the face and edges and is used as a rigid air barrier for residential buildings within the scope of NZS 3604. HomeRAB Pre-Cladding is manufactured in New Zealand by James Hardie and complies with the requirements of AS/NZS 2908.2.

It acts as temporary weather protection during construction, ideal for renovations or new construction. It is suitable for use as rigid underlay in residential buildings as per section 9.1.4 of E2/AS1 and complies with the requirements of Table 23 of E2/AS1. HomeRAB Pre-Cladding is suitable to withstand wind pressures experienced in all wind zones up to and including Very High (VH) wind zone as specified in NZS 3604. HomeRAB Pre-Cladding doesn't get fatigued or tear under the wind pressures exerted on it in the long term. HomeRAB Pre-Cladding has been tested to withstand wind pressures up to VH wind zone.

1.2 RAB Board 6mm is a 6mm thick fibre cement sheet which is sealed on the face and edges and is suitable for use as a rigid air barrier in Extra High (EH) wind zones or in wind pressures up to 4.5kPa.

It complies with the requirements of Table 23 of E2/AS1.

It is suitable for use as rigid underlay as per the requirement of section 9.1.4 of E2/AS1. RAB Board 6mm is also suitable to withstand high wind pressures experienced on building facades where it creates a wind barrier which equalises pressure within the cavity to the external pressures. Flexible underlays can deteriorate caused by positive/negative pumping actions created by gusting winds within the cavity and on building facade.

Due to these pressures a flexible underlay may not perform as desired in the long term. RAB Board 6mm has been tested to withstand wind pressures up to 4.5kPa(ULS).

1.3 RAB Board 9mm is a 9mm thick fibre cement sheet which is sealed on the face and edges and is suitable for use as a rigid air barrier in Extra High (EH) wind zones or in wind pressures up to 4.5kPa.

RAB Board 9mm is suitable for specific design shear wall for residential or commercial applications where the structural design require strong/stiffer shear walls.

RAB Board 9mm is an ideal rigid backing substrate for use behind the façade cavities to improve the acoustic performance of the wall assembly. The continuity of RAB Board 9mm on the exterior of framing with its heavier mass cuts down the environmental noise, blocks noise flanking paths and therefore enhances the overall acoustic performance of building facades.

It complies with the requirements of Table 23 of E2/AS1.

It is suitable for use as rigid underlay as per the requirement of section 9.1.4 of E2/AS1. RAB Board is also suitable to withstand high wind pressures experienced on building facades where it creates a wind barrier which equalises pressure within the cavity to the external pressures. Flexible underlays can deteriorate

caused by positive/negative pumping actions created by gusting winds within the cavity and on building facade.

Due to these pressures a flexible underlay may not perform as desired in the long term. RAB Board 9mm is suitable for use for wind pressures up to 4.5kPa(ULS).

1.4 James Hardie rigid air barriers provide the following benefits:

- Resistant to moisture damage and rotting when installed correctly
- Integral sealer applied on the face and edges repels moisture rapidly and helps resist moisture penetration
- Provides temporary weathertightness to the building envelope until the final claddings are installed
- Provides general rigidity to the entire structure
- An efficient way to achieve structural bracing

This manual covers the use of HomeRAB Pre-Cladding and RAB Board in external wall pre-cladding applications only. Further information relating to HomeRAB Pre-Cladding and RAB Board is also available in the following James Hardie design manuals:

- Fire and Acoustic Design Manual
- Bracing Design Manual

The Specifier or other responsible party for the project must ensure that the information in this manual is appropriate for the intended application and that specific design and detailing is undertaken for areas which are not covered in this manual.

James Hardie rigid air barriers have been tested to comply with the performance requirements of the New Zealand Building Code (NZBC).

James Hardie rigid air barriers have been BRANZ appraised. This should be read in conjunction with this installation manual. BRANZ Appraisal No. 611 can be viewed on www.jameshardie.co.nz or www.branz.co.nz.

1.5 Make sure your information is up to date

When specifying or installing James Hardie products, ensure you have the current manual. If you're not sure you do, or you need more information, visit www.jameshardie.co.nz or Ask James Hardie on 0800 808 868.

Table 1

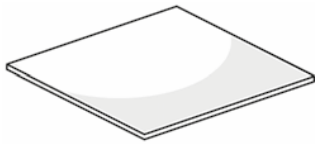
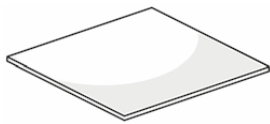
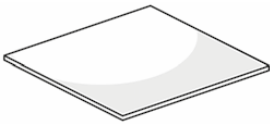
HomeRAB Pre-Cladding			
Product	Description	Sheet Sizes	
	HomeRAB Pre-Cladding A fibre cement sheet with a green water repellent sealer applied on the face and edges. Installed with green side facing out. Approximate mass: 6.5 kg/m ²	Thickness: 4.5mm	
		Length (mm)	Width (mm)
		2450	1200
		2750	1200
		Code	
		3000	1200
			404766
			404768
			404916
RAB Board 6mm			
Product	Description	Sheet Sizes	
	RAB Board A fibre cement sheet with a green water repellent sealer applied on the face and edges. Installed with green side facing out. Approximate mass: 8.6 kg/m ²	Thickness: 6mm	
		Length (mm)	Width (mm)
		2450	1200
		2750	1200
		Code	
		3000	1200
			402980
			405131
			402981
RAB Board 9mm			
Product	Description	Sheet Sizes	
	RAB Board A fibre cement sheet with a green water repellent sealer applied on the face and edges. Installed with green side facing out. Approximate mass: 12.2 kg/m ²	Thickness: 9mm	
		Length (mm)	Width (mm)
		2450	1200
		2750	1200
		Code	
		3000	1200
			405132
			404972
			404971

NOTE: All dimensions and masses provided are approximate only and are subject to manufacturing tolerances. Masses are based on Equilibrium Moisture Content (EMC) of product.

Table 2





Accessories/tools supplied by James Hardie			
	HomeRAB 4.5 Horizontal Flashing 3000mm long for horizontal joints CODE: 305798		HardieBlade™ Saw Blade 185mm diameter, Poly diamond blade for fast, clean cutting of James Hardie fibre cement. CODE: 300660
	RAB 6mm Horizontal Flashing 3000mm long for horizontal joints CODE: 305152		HardieKnife™ For easy cutting of fibre cement sheets. CODE: 305926
	RAB 9mm Horizontal Flashing 3000mm long for horizontal joints CODE: 305945		

Table 3







Components not supplied by James Hardie			
James Hardie recommends the following products for use in conjunction with its James Hardie rigid air barriers. James Hardie does not manufacture these products and does not provide a warranty for their use. Please contact component manufacturer for information on their warranties and further information on their products.			
	<p>Hand guillotine Guillotine for cutting fibre cement.</p>		<p>Sealing tape/window flashing tape Tape used to seal vertical joints and flash around window, door and pipe penetrations. SUPER-STICK Building Tape® - Marshall Innovations 0800 776 9727 3M™ All Weather Flashing Tape 8067 3M™ 0800 474 787</p>
	<p>Electric shear/fibreshear</p>		
	<p>Fibre cement nails 40 x 2.8mm hot dipped galvanised HardieFlex™ nails as per Table 5. 40 x 2.8mm stainless steel HardieFlex™ nails as per Table 5.</p>		<p>General installation - Nail gun and nails</p> <ul style="list-style-type: none"> Galvanised/stainless steel round head gun nails minimum length required for specific application.
	<p>Fibre cement nails 50 x 2.8mm hot dipped galvanised HardieFlex™ nails as per Table 5. 50 x 2.8mm stainless steel HardieFlex™ nails as per Table 5.</p>		
	<p>Tusk 160mm diameter blade Blade for fast, clean cutting of James Hardie fibre cement</p>		<p>Bracing installation - Nail gun and nails</p> <ul style="list-style-type: none"> Galvanised/stainless steel round head gun nail minimum length required for specific application. Refer to Section 4.3.

Figure 1: James Hardie Rigid Air Barriers with Linea™ Weatherboard

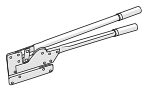

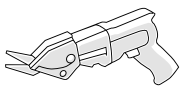
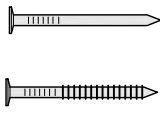
Figure 2: James Hardie Rigid Air Barriers with brick/block cladding

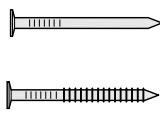

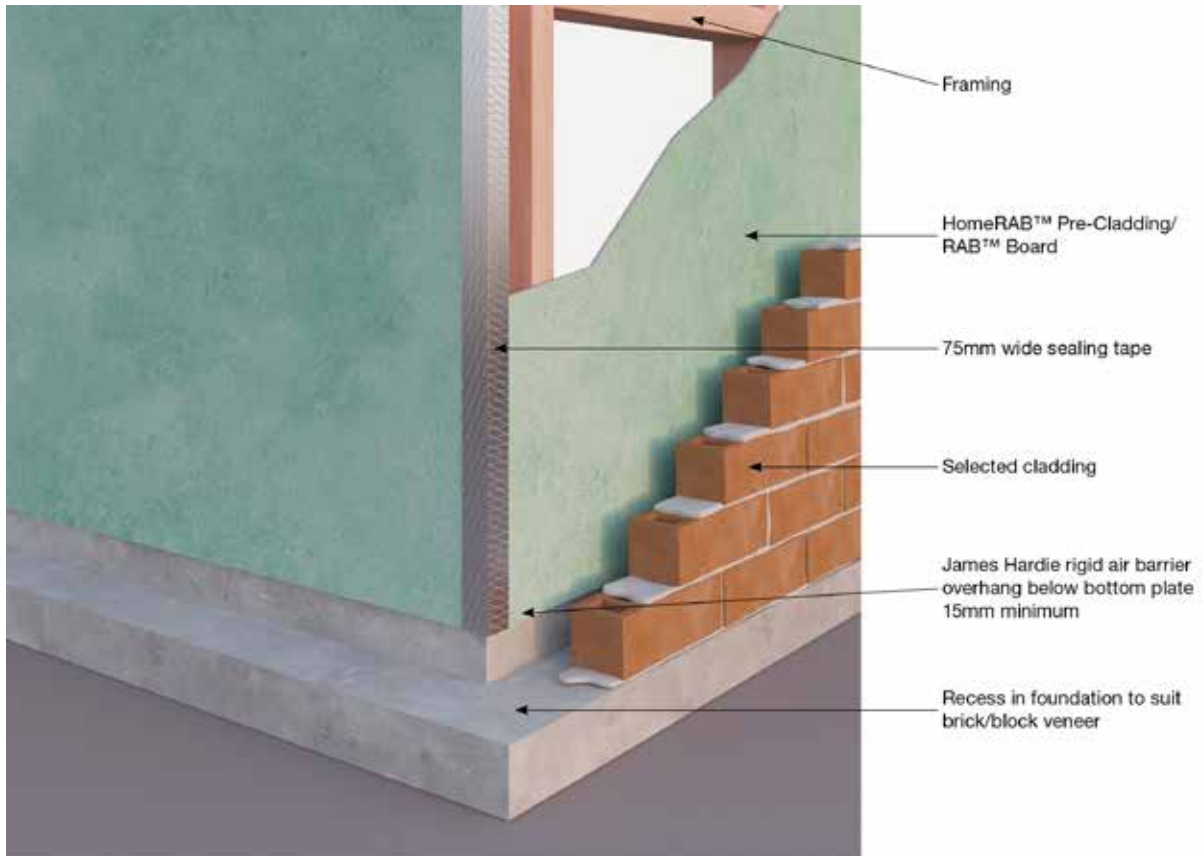
2 Safe working practices

2.1 STAY HEALTHY WHEN WORKING WITH BUILDING PRODUCTS CONTAINING CRYSTALLINE SILICA

Crystalline Silica

What is it? Why and when is it a health hazard?

Crystalline Silica is

- Commonly known as sand or quartz
- Found in many building products e.g. concrete, bricks, grout, wallboard, ceramic tiles, and all fibre cement materials

Why is Crystalline Silica a health hazard?

- Silica can be breathed deep into the lungs when present in the air as a very fine (respirable) dust
- Exposure to silica dust without taking the appropriate safety measures to minimise the amount being breathed in, can lead to a potentially fatal lung disease – silicosis – and has also been linked with other diseases including cancer. Some studies suggest that smoking may increase these risks
- The most hazardous dust is the dust you cannot see!









When is Crystalline Silica a health hazard?

- It's dangerous to health if safety protocols to control dust are not followed when cutting, drilling or rebating a product containing crystalline silica
- Products containing silica are harmless if intact (e.g. an un-cut sheet of wall board)

FAILURE TO ADHERE TO OUR WARNINGS, SAFETY DATA SHEETS AND INSTALLATION INSTRUCTIONS WHEN WORKING WITH JAMES HARDIE PRODUCTS MAY LEAD TO SERIOUS PERSONAL INJURY OR DEATH.

2.2 AVOID BREATHING IN CRYSTALLINE SILICA DUST!

Safe working practices

-  NEVER use a power saw indoors or in a poorly ventilated area
-  NEVER dry sweep
-  ALWAYS use M Class extractor unit as a minimum and always hose down with water/wet wipe for clean up
-  NEVER use grinders
-  ALWAYS use a circular sawblade specifically designed to minimise dust creation when cutting fibre cement – preferably a sawblade that carries the HardieBlade™ logo or one with at least equivalent performance
-  ALWAYS follow tool manufacturers' safety recommendations
-  ALWAYS expose only the minimum required depth of blade for the thickness of fibre cement to be cut
-  ALWAYS wear an approved properly-fitted, approved dust mask (P1 or P2) or respirator

Use one of the following methods based on the required cutting rate:





BEST

- HardieKnife™
- Hand guillotine
- Fibreshear





BETTER

- Dust reducing circular saw equipped with HardieBlade™ Saw Blade and M Class extractor unit.

Working outdoors

-  Make sure you work in a well ventilated area
-  Position cutting station so wind will blow dust away from yourself and others in the working area
-  Cut products with either a HardieKnife™ or fibre cement shears or, when not feasible, use a HardieBlade™ Saw Blade (or equivalent) and a dust-reducing circular saw attached to a M Class extractor unit
-  When sawing, sanding, rebating, drilling or machining fibre cement products, always:
 - Wear your P1 or P2 mask (correctly fitted in accordance with manufacturers' instructions) and when others are close by, ask them to do the same
 - If you are not clean shaven, then use a powered air respirator with a loose fitting head top
 - Wear safety glasses
 - Wear hearing protection
 - When others are close by, ask them to do the same

Working indoors

-  Never cut using a circular saw indoors
-  Position cutting station in a well ventilated area
-  Cut ONLY using a HardieKnife™, hand guillotine or fibreshears (manual, electric or pneumatic)
-  Make sure you clean up BUT never dry sweep. Always hose down with water/wet wipe or use an M Class extractor unit

IF CONCERN STILL EXISTS ABOUT EXPOSURE LEVELS OR YOU DO NOT COMPLY WITH THE ABOVE PRACTICES, YOU SHOULD ALWAYS CONSULT A QUALIFIED INDUSTRIAL HYGIENIST.

Working Instructions

- Refer to Recommended Safe Working Practices before starting any cutting or machining of product

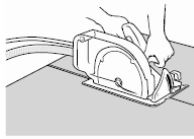

HardieBlade™ Saw Blade

The HardieBlade™ Saw Blade used with a dust-reducing saw is ideal for fast, clean cutting of James Hardie fibre cement products. A dust-reducing saw uses a dust deflector or a dust collector connected to a vacuum system. When sawing, clamp a straight-edge to the sheet as a guide and run the saw base plate along the straight edge when making the cut

Hole-Forming

For smooth clean cut circular holes:

- Mark the centre of the hole on the sheet
- Pre-drill a 'pilot' hole
- Using the pilot hole as a guide, cut the hole to the appropriate diameter with a hole saw fitted to a heavy duty electric drill

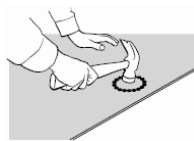

For irregular holes:

- Small rectangular or circular holes can be cut by drilling a series of small holes around the perimeter of the hole then tapping out the waste piece from the sheet face
- Tap carefully to avoid damage to sheets, ensuring that the sheet edges are properly supported

2.3 STORAGE AND DELIVERY

Keeping products and people safe

Off loading

- 👍 James Hardie products should be off-loaded carefully by hand or by forklift
- 👍 James Hardie products should not be rolled or dumped off a truck during the delivery to the jobsite

Storage

James Hardie products should be stored:

- 👍 In their original packaging
- 👍 Under cover where possible or otherwise protected with a waterproof covering to keep products dry
- 👍 Off the ground – either on a pallet or adequately supported on timber or other spacers
- 👍 Flat so as to minimise bending

James Hardie products must not be stored:

- 👎 Directly on the ground
- 👎 In the open air exposed to the elements

JAMES HARDIE IS NOT RESPONSIBLE FOR DAMAGE DUE TO IMPROPER STORAGE AND HANDLING.

2.4 TIPS FOR SAFE AND EASY HANDLING

Weatherboard products

- 👎 Do not lift planked products flat and in the middle
- 👍 Carry the products on the edge
- 👍 If only one person is carrying the product, hold it in the middle and spread arms apart to better support the product
- 👍 If two people are carrying the plank, hold it near each end and on edge
- 👍 Exercise care when handling weatherboard products to avoid damaging the edges/corners

Sheet products

- 👍 Carry with two people
- 👍 Hold near each end and on edge
- 👍 Exercise care when handling sheet products to avoid damaging the edges/corners

3 Applications

HomeRAB Pre-Cladding is suitable for use as a rigid air barrier for residential buildings up to and including VH wind zone within the scope of NZS 3604 and E2/AS1. HomeRAB Pre-Cladding is fixed directly to the framing. The vertical joints are sealed over the face of the HomeRAB Pre-Cladding. HomeRAB Pre-Cladding is suitable for use behind all James Hardie claddings or alternative claddings such as brick, timber weatherboard, EIFS etc.

RAB Board is suitable for use as a rigid air barrier in EH wind zone in residential or SED project applications to withstand high wind pressures in conjunction with cladding/commercial facades. In these applications, RAB Board is fixed directly to the framing. The vertical joints are sealed over the face of the RAB Board using joint flashing tape.

3.1 JAMES HARDIE RIGID AIR BARRIER

James Hardie rigid air barriers can remain exposed to the external elements for maximum 180 days prior to the external cladding being installed.

The James Hardie rigid air barriers can be used as a backing board behind stucco plasters. Refer to James Hardie Stucco Solution technical specification, E2/AS1 'External Moisture' clause of the NZBC and BRANZ 'Weathertight Solutions Stucco' for further information on stucco plaster. The RAB Board can also be used as a backing board behind other proprietary claddings which comply with the NZBC requirements. Proprietary cladding must be installed as per their manufacturing specifications. In these applications, a building underlay must be used as a slip layer to cover RAB Board and ensure a separation between mortars and RAB Board. The RAB Board is fixed over a minimum 18mm thick cavity batten for these applications. The RAB Board may also be required over the framing to withstand high wind pressures within the cavity.

The claddings/facades used over James Hardie rigid air barriers must satisfy the various performance requirements of the NZBC.

Horizontal profiled metal and uPVC claddings must not be direct fixed over James Hardie rigid air barriers. These must be fixed over an underlay or overlay the James Hardie rigid air barrier using the cavity construction method.

Vertical profiled metal cladding can be direct fixed over James Hardie rigid air barriers with a flexible underlay separator to comply with manufacturers recommendations.

The cladding fastener length must be increased by 5mm minimum to maintain the required nail pull out strength.

In case of gable end trusses sitting on top plates of external wall frame, the frame size must comply with the minimum timber sizes stipulated for wall frames in Section 8 of the NZS 3604.

3.1.1 Temporary weather protection

Installation of internal lining can be started after James Hardie rigid air barriers have been installed on the exterior of the building envelope. In order to achieve this, all sheet joints and penetrations must be sealed and the roof, soffit lining, windows/doors (including head flashings and airseals) must have been installed to ensure the building is weathertight before starting the installation of internal linings. The insulation, electrical cables, plumbing and any other services required in external walls must be installed and inspected by the building consent authority before starting the installation of internal linings. The internal lining and services must be installed in accordance with their manufacturer's product literature and comply with the NZBC requirements.

The claddings must be installed within 180 days after the installation of James Hardie rigid air barriers.

3.1.2 Bracing

For bracing application the James Hardie rigid air barriers must be installed as per HomeRAB Pre-Cladding/RAB Board bracing details in the James Hardie Bracing Design Manual. Bracing with rigid air barriers can only be achieved when fixed direct to frame. The board must be fixed in accordance with the bracing details to all framing. For further information on bracing refer to Section 6 and the James Hardie Bracing Design Manual or Ask James Hardie on 0800 808 868.

3.1.3 Fire rated wall construction

RAB Board is classified as 'Non-Combustible Material'. For fire rated wall applications RAB Board must be installed as per the current James Hardie Fire and Acoustic Design Manual. RAB Board is suitable to achieve fire ratings up to 60 minutes when installed in accordance with fire systems specifications published in the James Hardie Fire and Acoustic Design Manual. The board must be fixed with HardieFlex nails at 150mm centres to all framing.

3.2 STUD TO TOP PLATE FIXING

Refer to Section 5.2, Figures 16 and 17 for alternative stud to top plate connection.

3.3 SEISMIC DEFLECTIONS

RAB Board is suitable for use as rigid backing in buildings where the structure is designed to expect the lateral inter-storey seismic deflections. The seismic deflections can have a significant effect on the performance of the façade system and its components, therefore it is crucial to first understand the amount of inter-storey deflections and then to choose a suitable rigid air barrier and façade system that has been tested to meet the performance appraised.

James Hardie has a range of tested cladding/façade systems with RAB Board that are suitable for a range of seismic deflection. For further design and installation guidance, refer to clause 5.3.3 of this manual and Figure 26.

4 Framing and fixings

4.1 FRAMING

The timber framing shall be in accordance with NZS 3604 or comply with the specific engineering design requirements. The timber treatment must comply with NZBC Acceptable Solution B2/AS1 requirements.

The minimum framing size required for fixing James Hardie rigid air barriers is 90 x 45mm. Ensure that the framing is suitable for installing the selected cladding. Refer to cladding installation manual for further information about the framing requirements.

For specific engineering design projects where the timber framing differs from what's been provided in this manual, Ask James Hardie on 0800 808 868.

Table 4

Product	Wind zone	Framing centres (max)
HomeRAB Pre-Cladding	Up to and including H (High)	600mm
HomeRAB Pre-Cladding	Very High	400mm
RAB Board	Up to and including VH (Very High)	600mm
RAB Board	EH (Extra High) & SED (above 1.5kPa to 4.5kPa)	400mm

NOTE:

- HomeRAB Pre-Cladding must not be used in EH, SED wind zones and on fire rated wall application. Use RAB Board instead

4.2 FIXINGS

James Hardie rigid air barriers must be installed with its sealed face towards the external cladding and unsealed face towards the framing. The sealer applied on the face helps the board to drain the moisture freely over the face and keeps it dry.

- Nails must finish flush with board surface

The HomeRAB Pre-Cladding and RAB Board are fixed as described below.

HomeRAB Pre-Cladding and RAB Board can either be gun nailed or hand nailed. It is recommended to use gun nails to cut down installation time. When gun nailing, follow nail gun manufacturer's instructions for correct operation of tool and site safety requirements.

- Nails must have a minimum clearance of 12mm from the sheet edges and a minimum of 50mm horizontally and 75mm vertically from the sheet corners
- When using a nail gun the gun nails must have a full round head to provide the required holding power, and minimum length of the hand nail

Note:

- Refer to Table 5 regarding nail sizes and fixing centres for various applications

Table 5

HomeRAB Pre-Cladding/RAB Board 6mm			
Application	Type of nail	Nailing centres to all framing	Nailing option
General	40 x 2.8mm HardieFlex nail	200mm	Gun nail or hand nail
Fire rating	40 x 2.8mm HardieFlex nail	150mm	Gun nail or hand nail
Bracing	40 x 2.8mm HardieFlex nail	100mm 150mm	Gun nail or hand nail
Stucco plaster (over cavity)	60 x 3.15mm HardieFlex nail	200mm	Gun nail or hand nail

RAB Board 9mm			
Application	Type of nail	Nailing centres to all framing	Nailing option
General	50 x 2.8mm HardieFlex nail	200mm	Gun nail or hand nail
Fire rating	50 x 2.8mm HardieFlex nail	150mm	Gun nail or hand nail
Bracing	50 x 2.8mm HardieFlex nail	100mm 150mm	Gun nail or hand nail

NOTE:

- Nails must finish flush with board surface
- Nails must have minimum clearance of 12mm from the sheet edges and a minimum of 50mm horizontally and 75mm vertically from the sheet corners
- Do not use D-head nails

4.3 FASTENER DURABILITY

Fasteners must have the appropriate level of durability required for the intended project to comply with the NZBC. This is of particular importance in coastal areas, areas subject to salt spray and other corrosive environments. Refer to Table 6 for information regarding the types of nails to use to comply with the durability requirements of the NZBC.

Table 6

Exposure conditions and nail selection prescribed by NZS 3604		
Zone	Application	Nail material
D (Sea Spray) * and Geothermal hot spots	General	Stainless steel 304/316
	Fire	
	Bracing	
C and B	General	Hot dip galvanised**
	Fire	
	Bracing	

*Where local knowledge dictates that increased durability is required use stainless steel nails

** Hot dip galvanised must comply with AS/NZS 4680

Fasteners must be fully compatible with all other materials that they are in contact with to ensure the durability and integrity of the assembly. Contact fastener manufacturers for more information. Also refer to Table 20 and 21 of E2/AS1 for further information about the suitable fastening materials and their compatibility with other materials.

Figure 3: James Hardie rigid air barriers layout

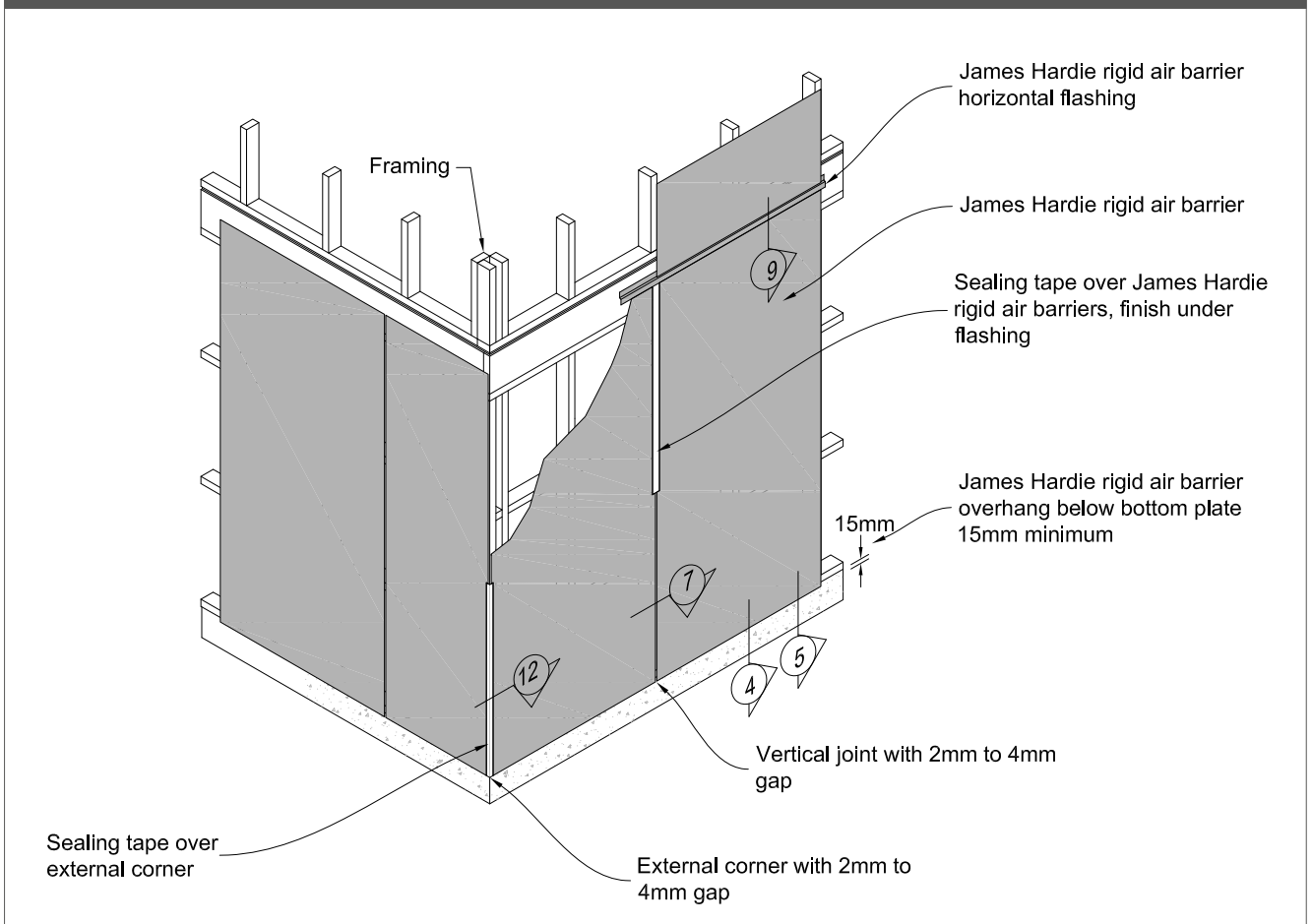

4.4 CLEARANCES

James Hardie rigid air barriers must extend below the bottom plate by 15mm minimum over concrete foundation and 15mm past floor joist of timber foundation. James Hardie rigid air barriers must maintain a 100mm minimum clearance between the bottom edge of the sheet and the finished ground.

Check cladding manufacturer for minimum clearances required for the selected cladding.

Maintain the required clearances between the bottom plate and top of ground to comply with the NZBC and NZ standards. The adjacent finished ground must slope away from the building in accordance with the NZBC requirements. Do not install James Hardie rigid air barriers in such a way that it may remain in contact with standing water.

Figure 4: Foundation detail — direct fix cladding

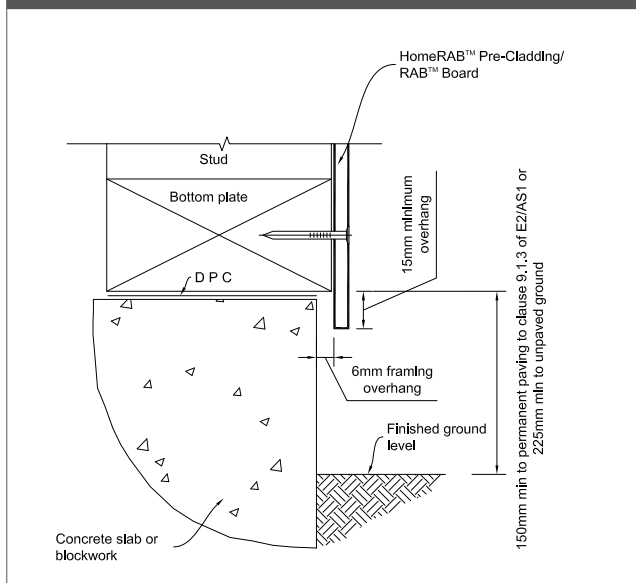

Figure 5: Foundation detail — cavity fix cladding

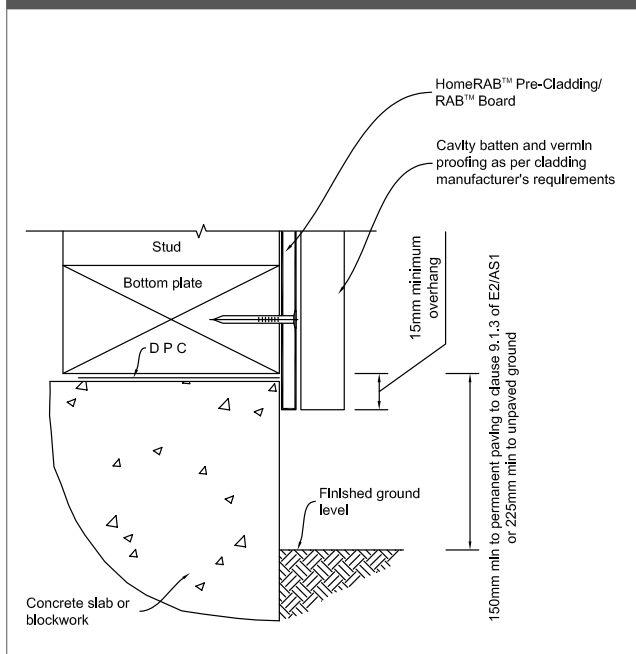
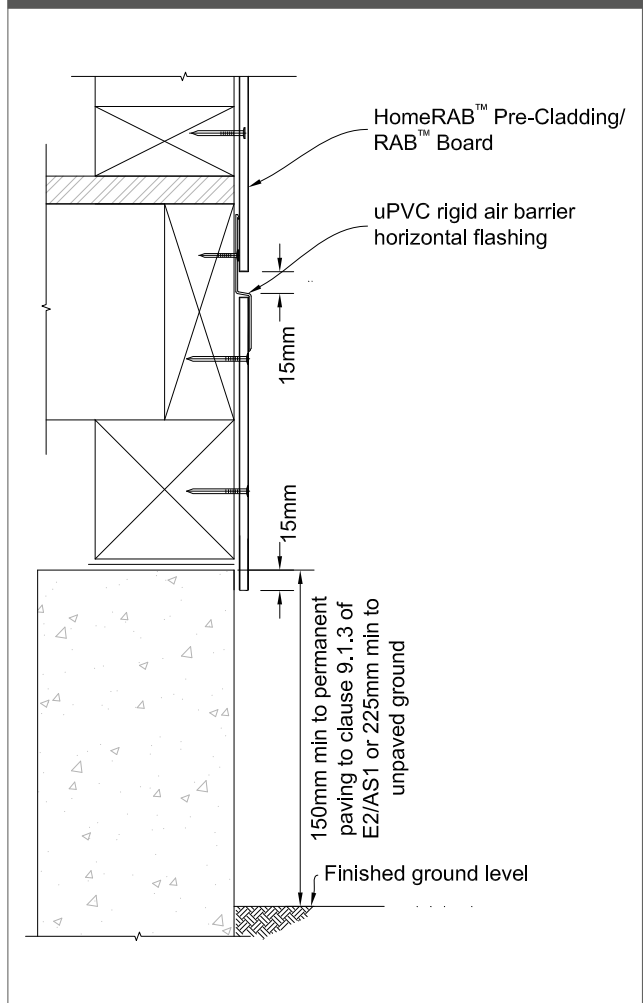

Figure 6: Foundation detail – timber foundation



5 Installation

5.1 BOARD LAYOUT

When using James Hardie rigid air barrier, building underlays are not required over the framing. HomeRAB Pre-Cladding/RAB Board have been tested and comply with the performance requirements of Table 23 of Clause E2 of the NZBC. The sheets are jointed keeping a gap of 2-4mm maximum between the sheet edges. The board must be cleaned of any dust before fixing the jointing tape over the joint.

Cut edges where exposed must be primed prior to installation with Dulux® 1 Step, Resene Quick Dry or similar.

The bottom edge of James Hardie rigid air barriers must overhang below the bottom plate by 15mm minimum, refer to Figures 4 and 5.

5.1.1 Vertical joints

Vertical joints must be sealed to stop the moisture ingress into the framing behind James Hardie rigid air barrier. The vertical joints are sealed over by running a 75mm wide sealing tape e.g. SUPER-STICK Building Tape/3M All Weather Flashing Tape 8067.

The sealing tapes must be pressed hard over the James Hardie rigid air barriers surface while fixing so that they achieve the required bond. The sealing tapes must not be exposed to elements for more than 180 days. This achieves the required protection when the cladding is installed. The claddings must be installed within 180 days.

NOTE: Refer to sealing tape manufacturers recommendations regarding the installation of their sealing tapes in cold climate

conditions. It is recommended to warm up the sealing tapes eg when the air and substrate temperatures are below 10°C. Check with tape manufacturer for their recommendations

5.1.2 Horizontal joints

The horizontal joint of James Hardie rigid air barriers must be flashed using a uPVC horizontal flashing or alternatively aluminium or colour steel Z flashings can also be used. Refer to Figures 8, 9 and 10. Leave a gap of 15mm minimum at the solid timber floor joist or as specified by the project engineer. The flashing must be lapped by a 35mm minimum on both sides of the joint.

For walls longer than 3m, horizontal uPVC flashing must be lapped by 50mm minimum and silicone sealed.

Rigid air barriers must not be fixed into floor joists.

5.1.3 Internal/external corners

James Hardie rigid air barrier corner joints must be sealed using a 75mm minimum wide sealing tape.

When using a uPVC horizontal flashing in horizontal joints, the internal and external corner flashing joints must be sealed using a 75mm minimum wide joint sealing tape. Refer to Figures 13a, 13b and 13c.

When using James Hardie rigid air barrier as a backing board for stucco plaster, the vertical joints of James Hardie rigid air barrier are not required to be sealed using flashing tapes. The horizontal joints at floor level and in tall walls must be flashed to satisfy the requirements of clause E2 of the NZBC.

Figure 7: Vertical joint

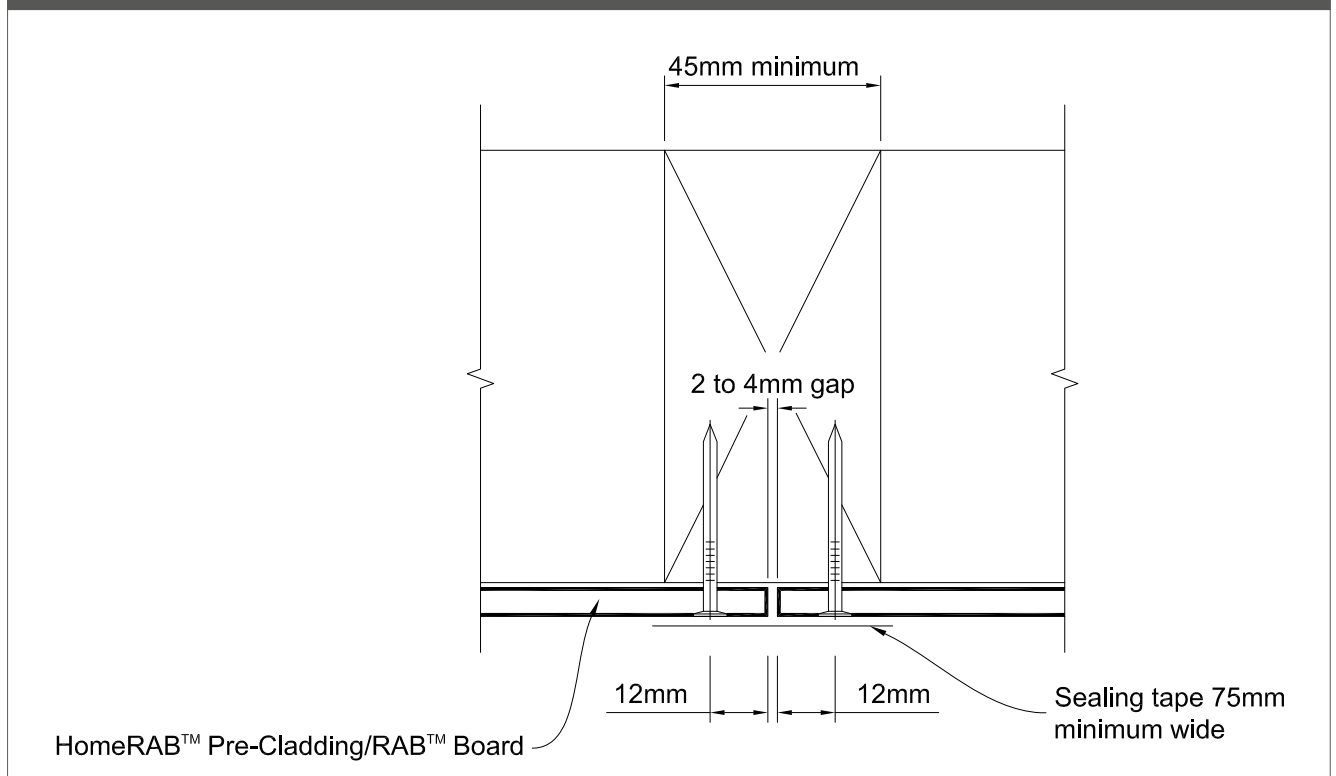

5.1.4 Flexible underlay

James Hardie rigid air barriers can also be used in conjunction with flexible underlay in accordance with Section 9.1.7.2 of E2/AS1. When installing rigid underlay as per E2/AS1 requirements, its horizontal and vertical joint does not require to be sealed with flashing tapes, but instead, a flexible underlay is applied over the entire rigid air barrier in accordance with Section 9.1.7.1. The

flexible underlay must comply with Table 23 of E2/AS1. The wall openings must be flashed in accordance with E2/AS1 and this installation manual.

Figure 8: Horizontal joint flashing - tall wall

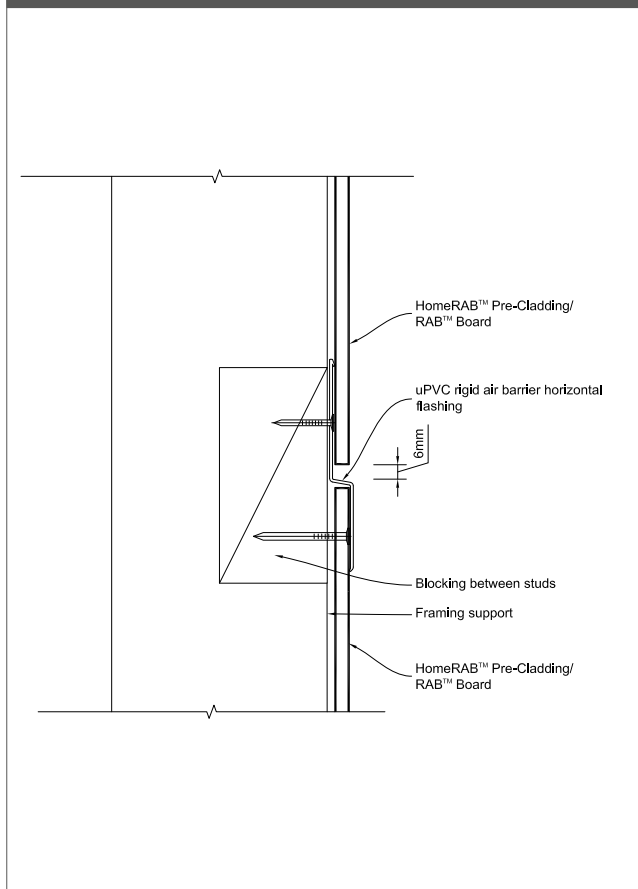

Figure 9: Horizontal joint/flashing - floor joist

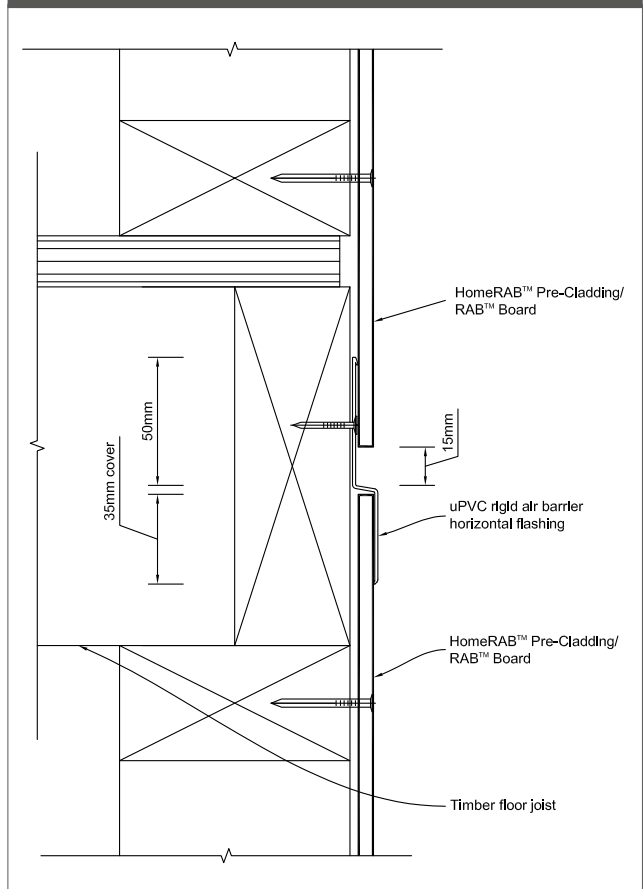

Figure 10: Horizontal joint flashing - concrete beam

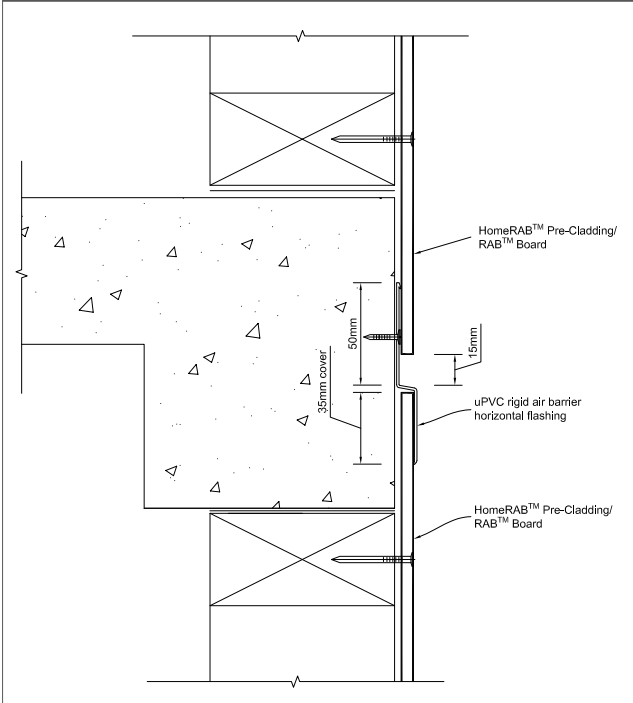

Figure 11: Internal corner joint

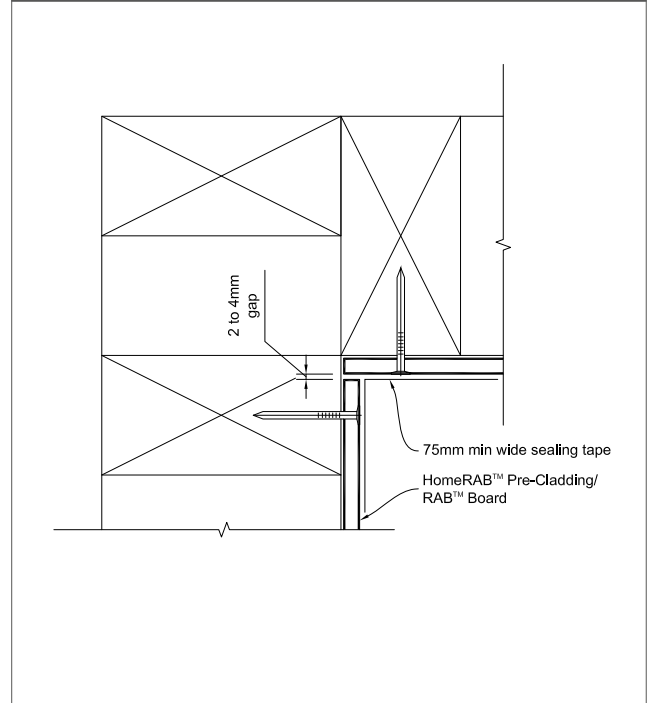

Figure 12: External corner joint

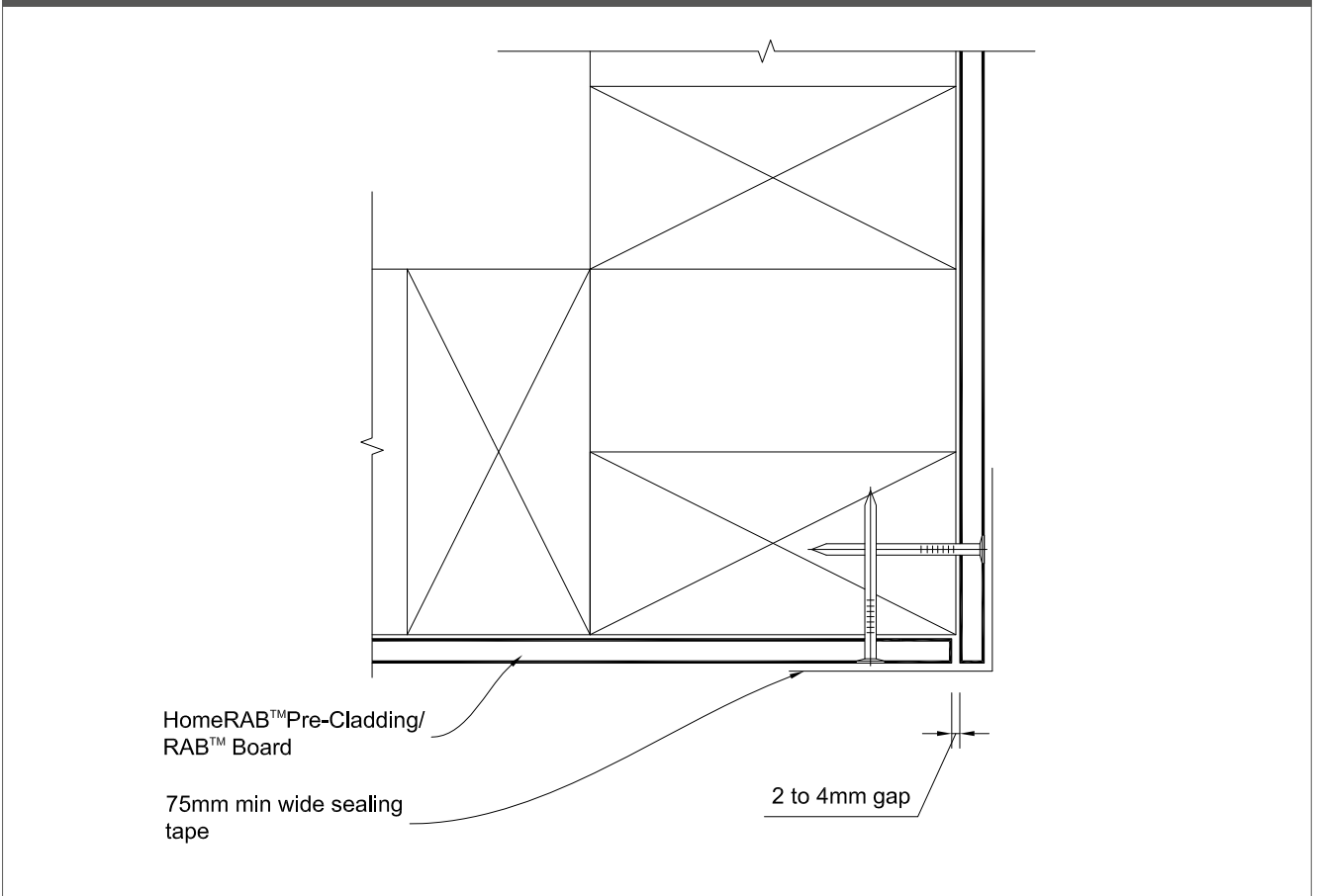

Figure 13a: Corner junction to horizontal joint

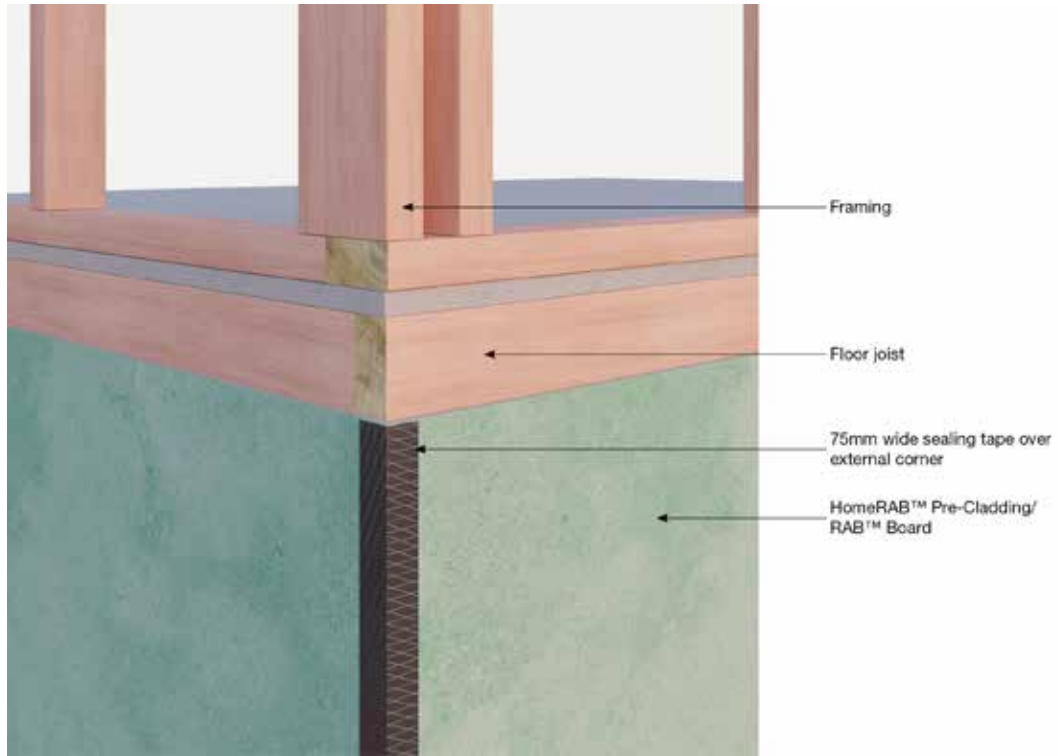

Figure 13b: Corner junction to horizontal joint

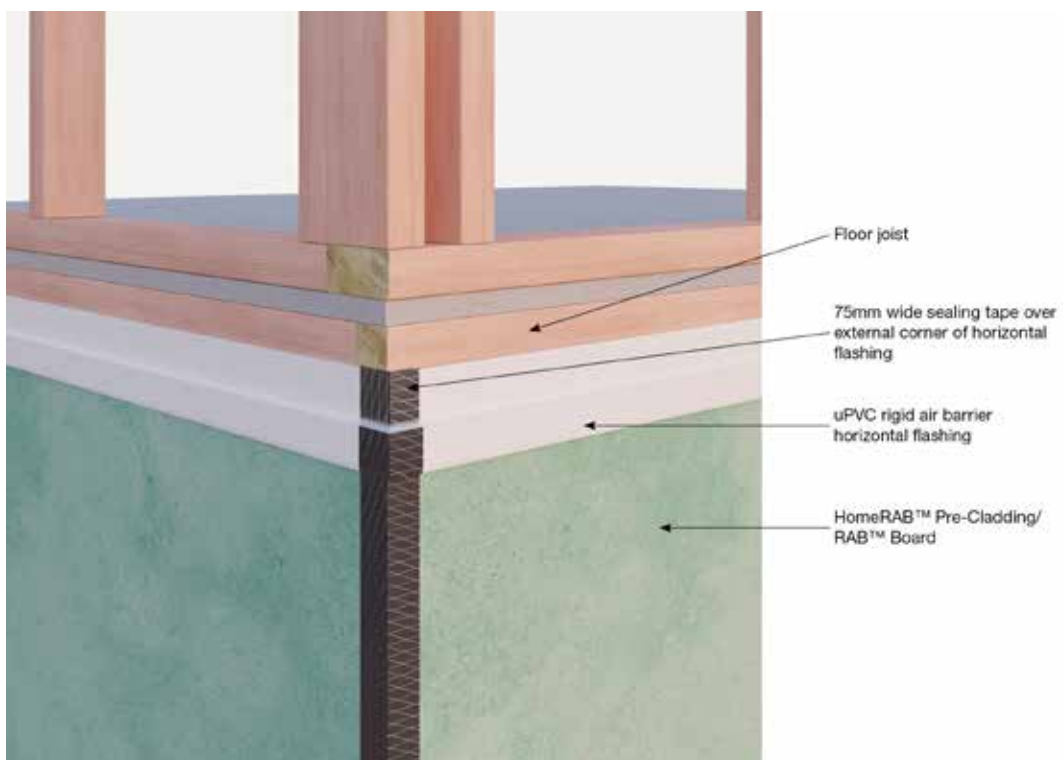

Figure 13c: Corner junction to horizontal joint

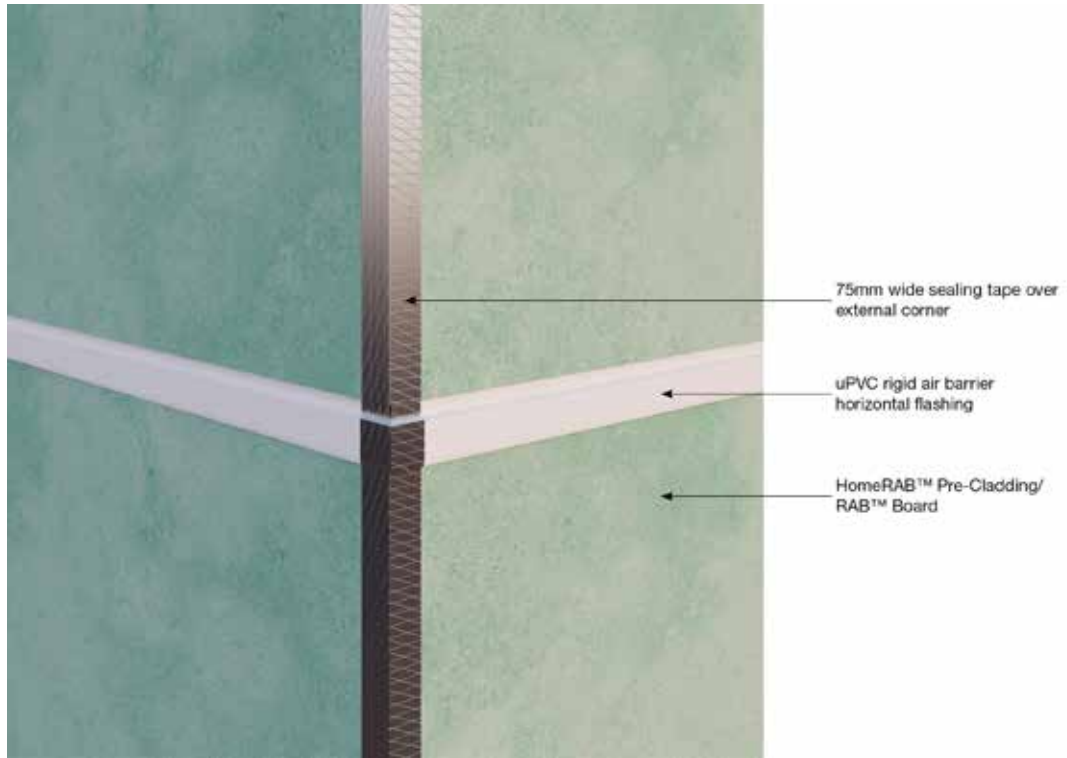

Figure 14: RAB Board used as backing board for stucco plaster/proprietary cladding systems

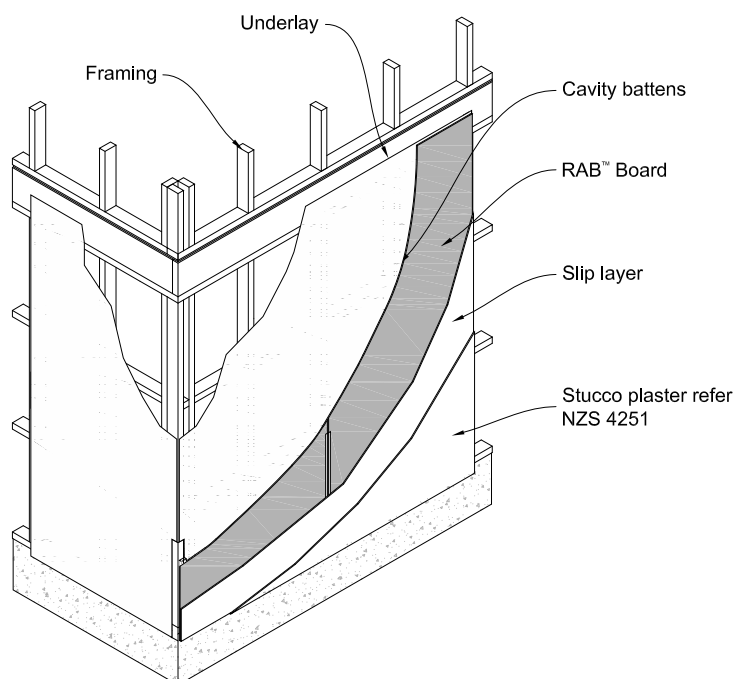
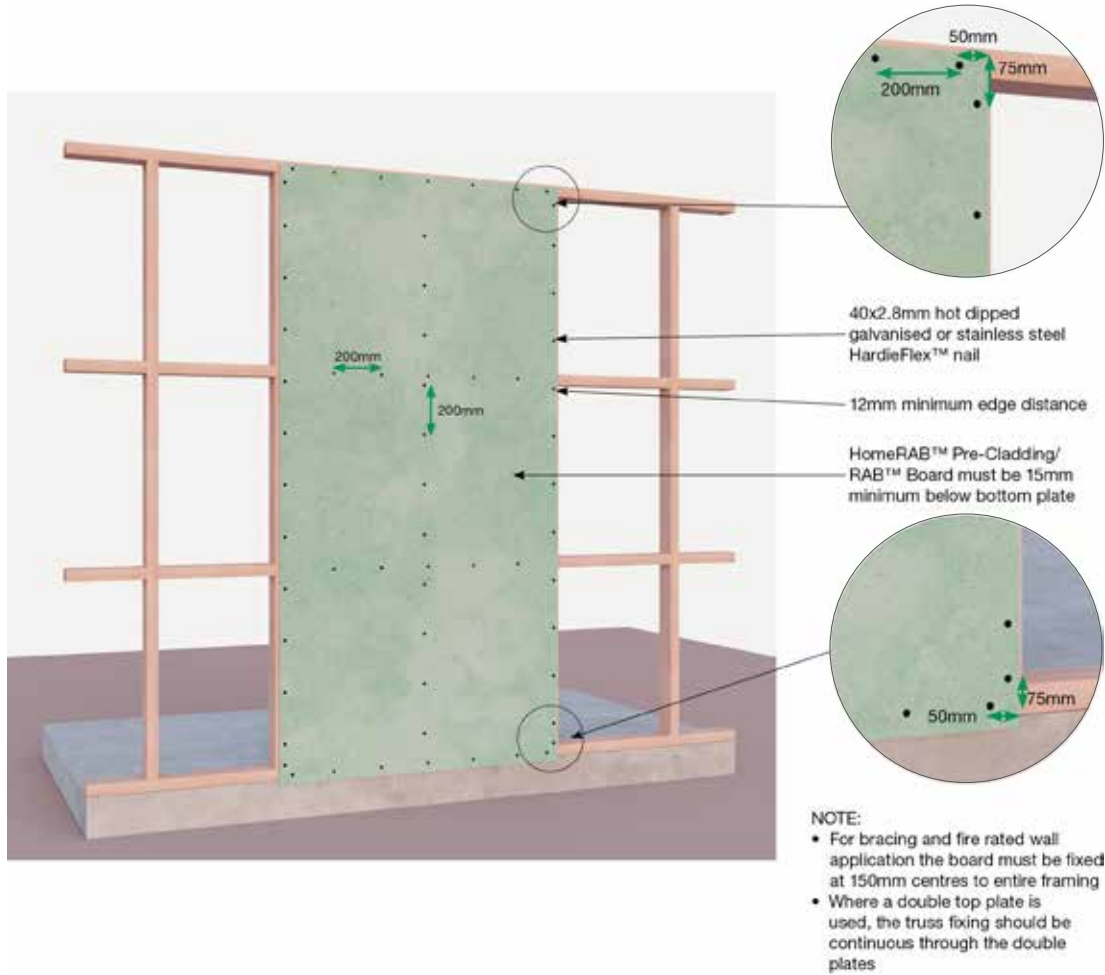

Figure 15: Sheet Fixing - General Application



5.2 STUD TO TOP PLATE FIXING

Table 8.18 of NZS 3604 specifies two types of fixings i.e. Type-A with a fixing capacity of 0.7kN and Type-B with a fixing capacity 4.7kN. HomeRAB Pre-Cladding or RAB Board rigid air barriers have been tested and are verified as suitable alternatives to achieve the required stud to top plate connectivity as mentioned above and no special use of straps/plates or wire dogs etc. is required.

For a 0.7kN connectivity, the standard fixing of HomeRAB Pre-Cladding and RAB Board using 40 x 2.8mm HardieFlex nails at 200mm centres maximum will achieve this.

For a 4.7kN connectivity, fix HomeRAB Pre-Cladding or RAB Board using 40 x 2.8mm HardieFlex nails or gun nail at 75mm centres maximum to top plate with a minimum edge distance of 20mm. Refer to Figure 16.

Figure 16: Stud to top plate connection

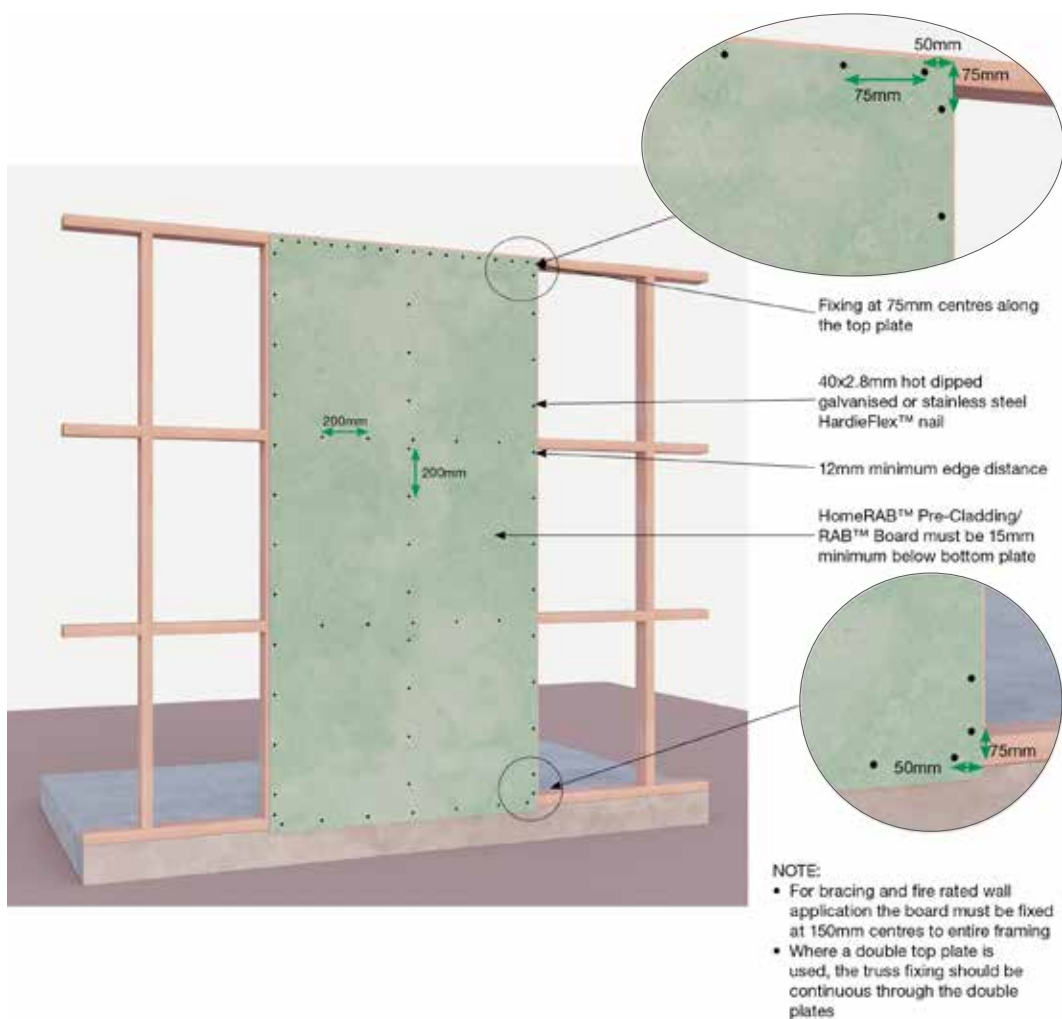
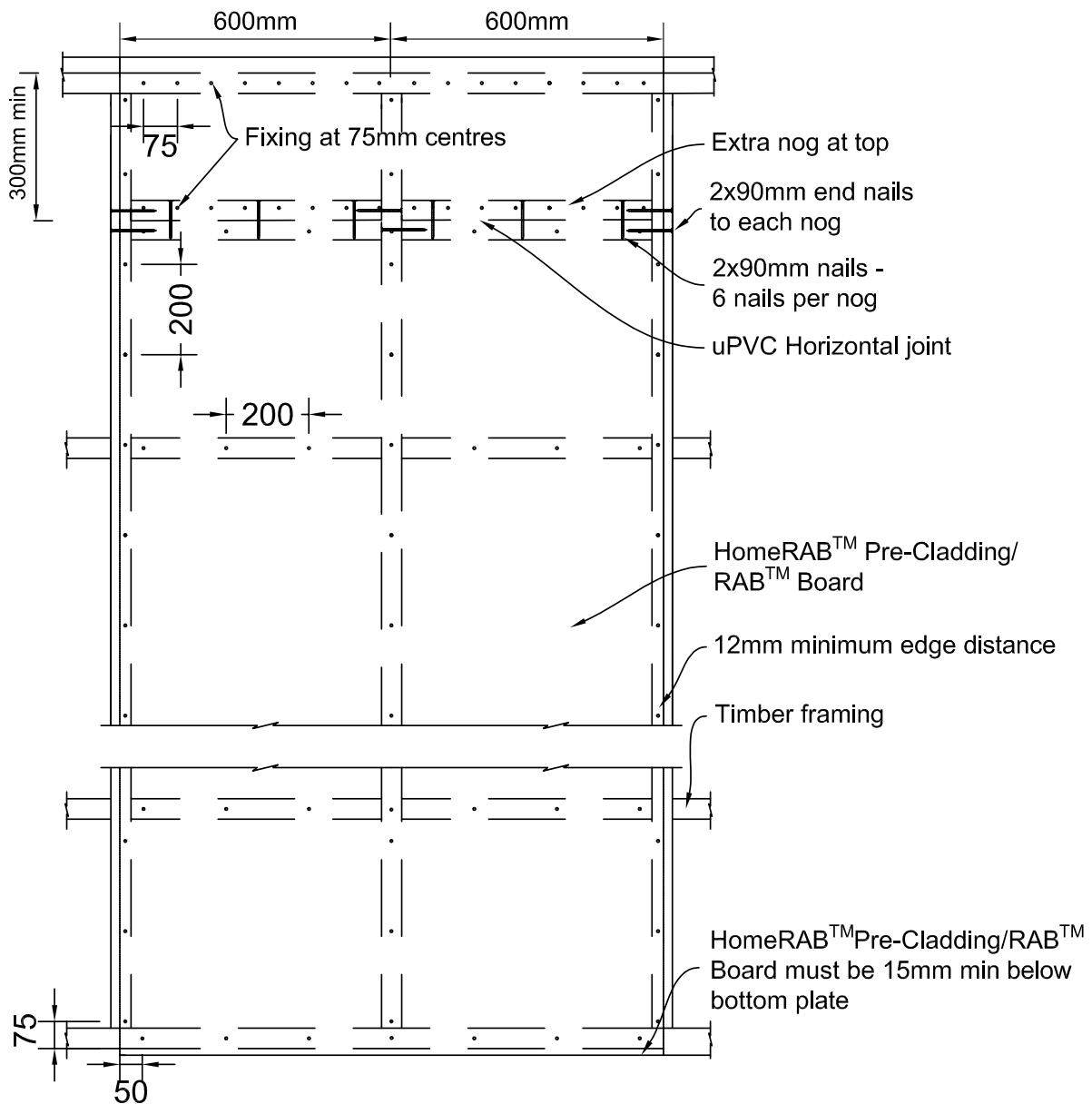

Figure 17: Stud to top plate connection - tall wall



Note:

1. Where a double top plate is used, the truss fixing should be continuous through the double plates.
2. For bracing and fire rated wall application, the board must be fixed at 150mm c/c to entire framing.

Figure 18: Lintel connection

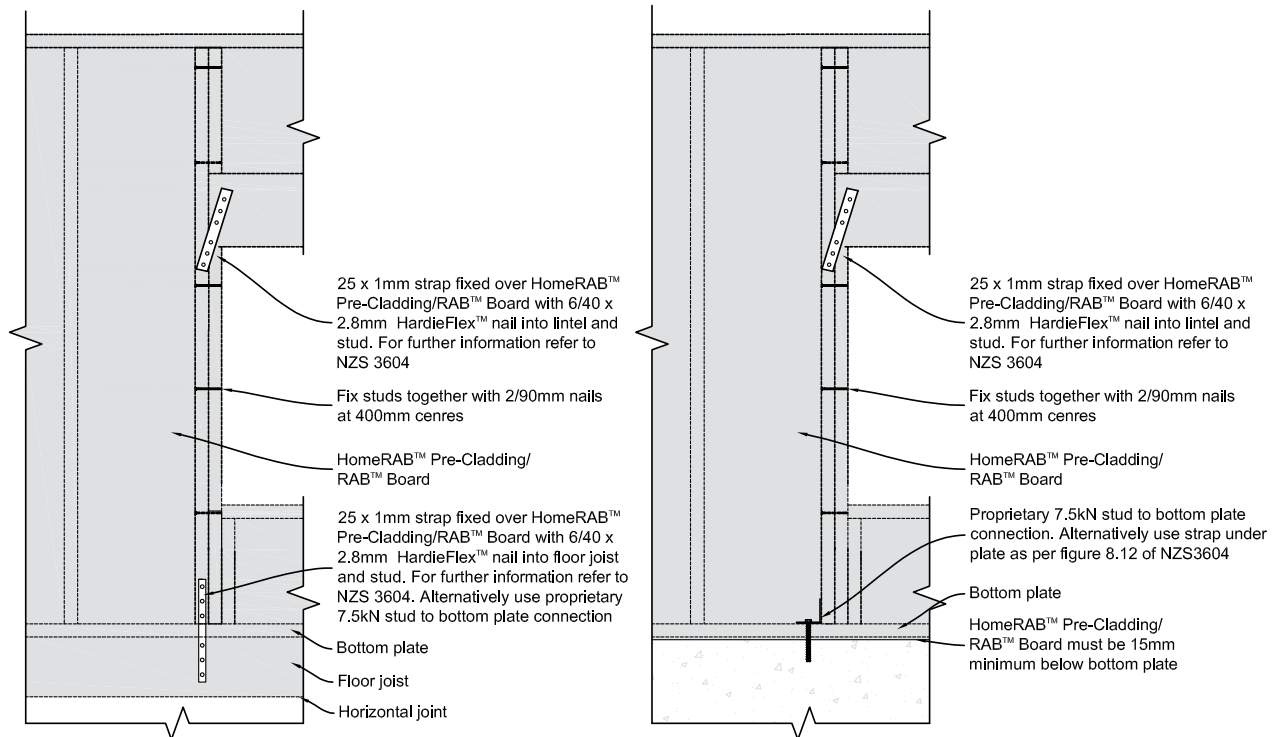

5.3 FLASHINGS

The exposed timber framing around the window jamb can be covered with a 150mm minimum wide flashing tape or a sealing tape refer to Figures 19 and 20. The window sill must be dressed with a 150mm minimum wide flashing tape. The tape is sealed over the face of the James Hardie rigid air barrier.

The James Hardie rigid air barrier surface must be clean, free of grime and dry before the tapes are applied. Some tape manufacturers require a primer tak spray be applied before fixing the tapes to the board surface to achieve a better tape adhesion. Check with the tape manufacturers for further information regarding minimum requirements etc.

Figure 19: Window sealing with flashing tapes

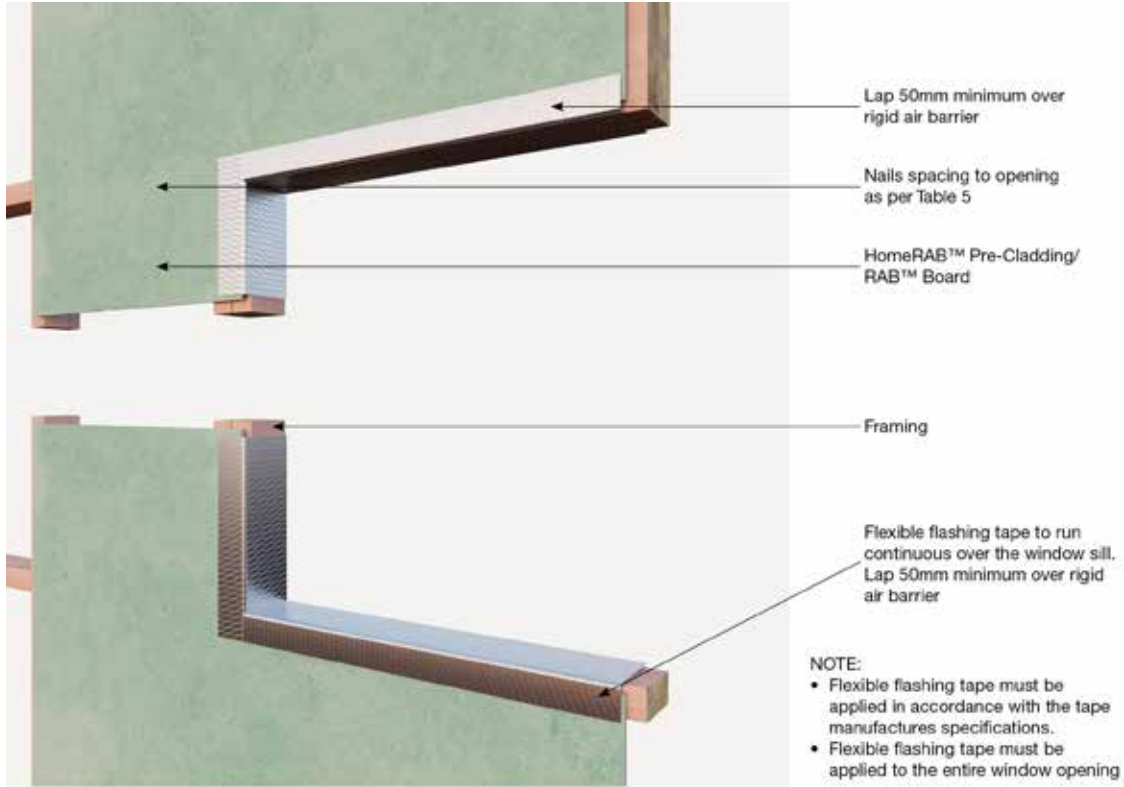

Figure 20: Window jamb with flashing tape

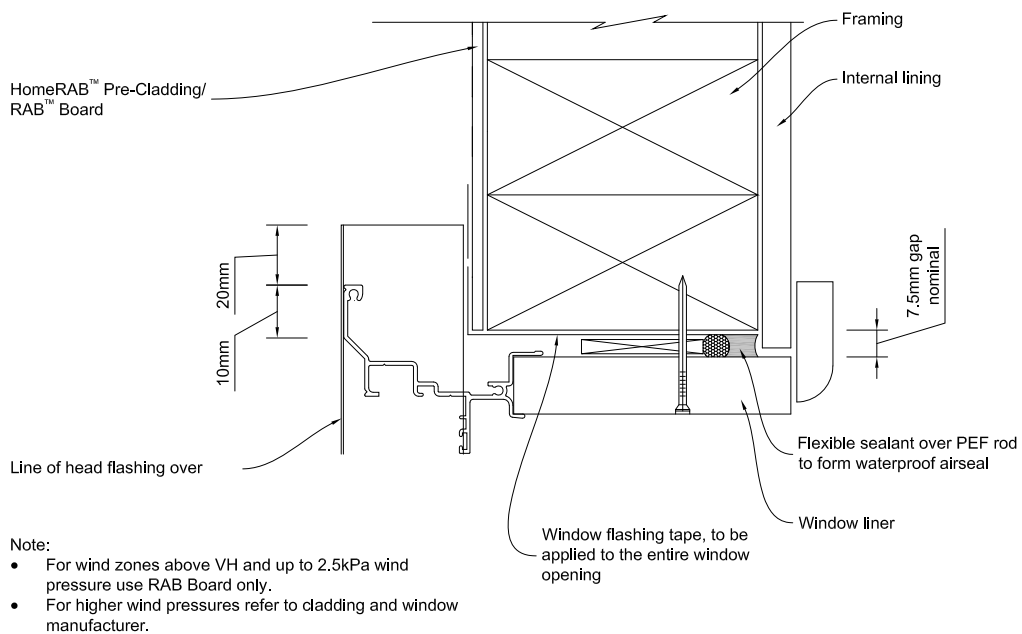

Figure 21: James Hardie rigid air barriers to standard soffit

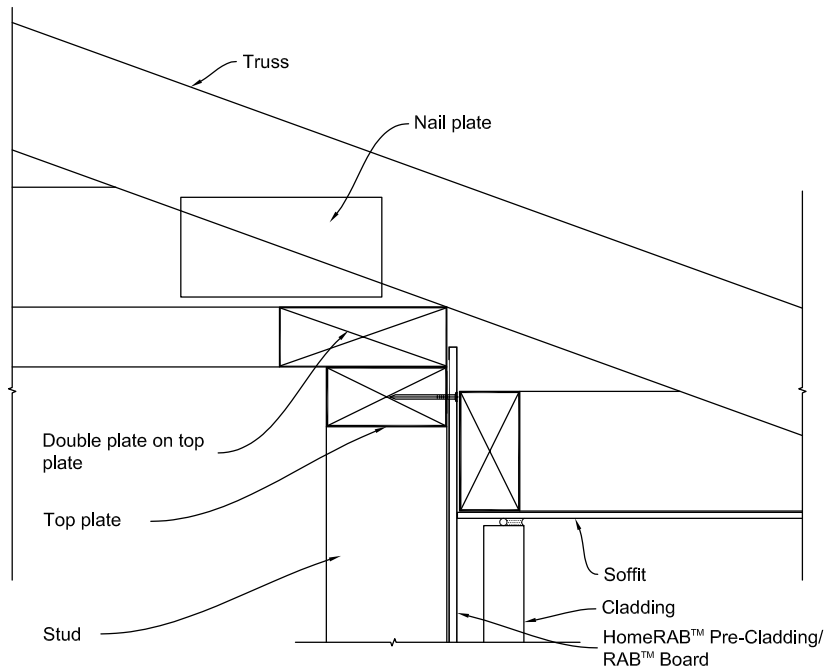
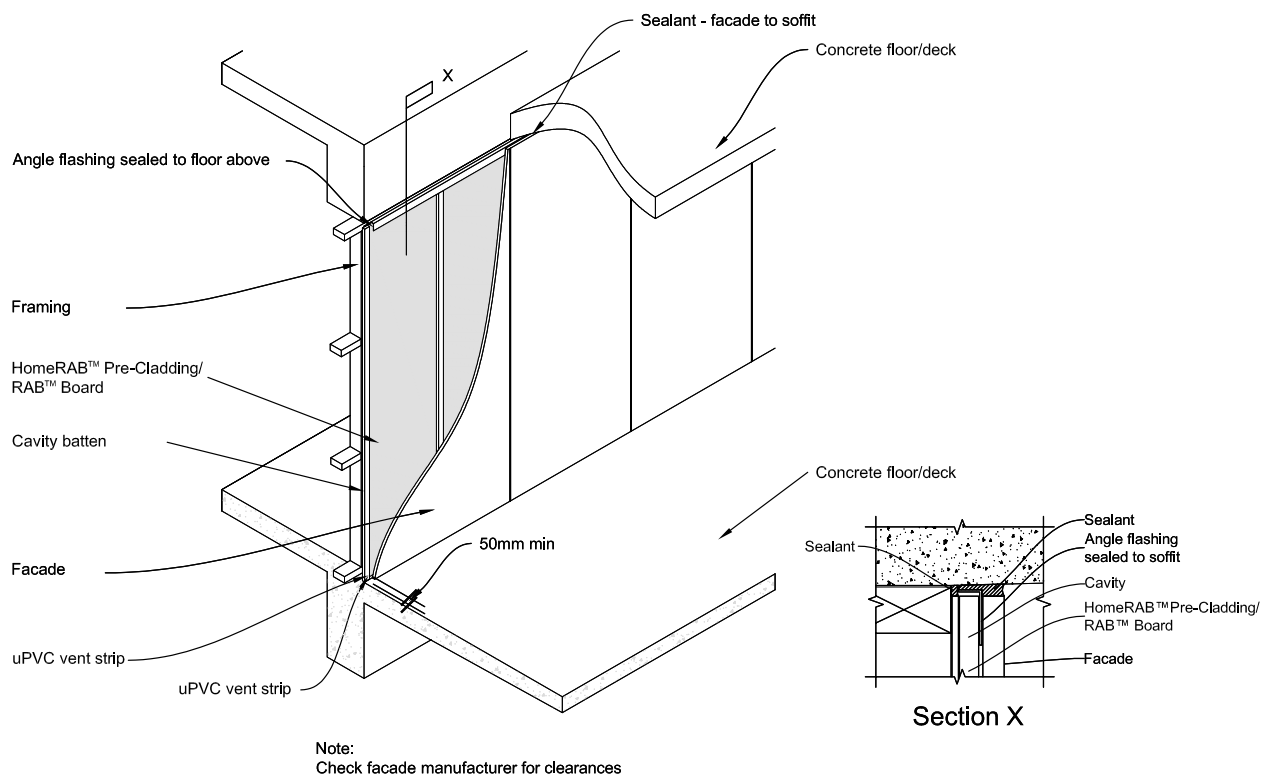

Figure 22: RAB Board to concrete slab junction



5.3.1 Penetrations

The pipe penetrations through James Hardie rigid air barrier must be sealed securely using a flexible flashing tape. Maintain a 100mm minimum cover of flashing over the board around the penetration.

5.3.2 Balustrade to wall junctions

The junctions between balustrades to wall should be appropriately flashed. Refer to E2/AS1 of the NZBC for information and flashing details.

Figure 23: Pipe penetration through James Hardie rigid air barriers

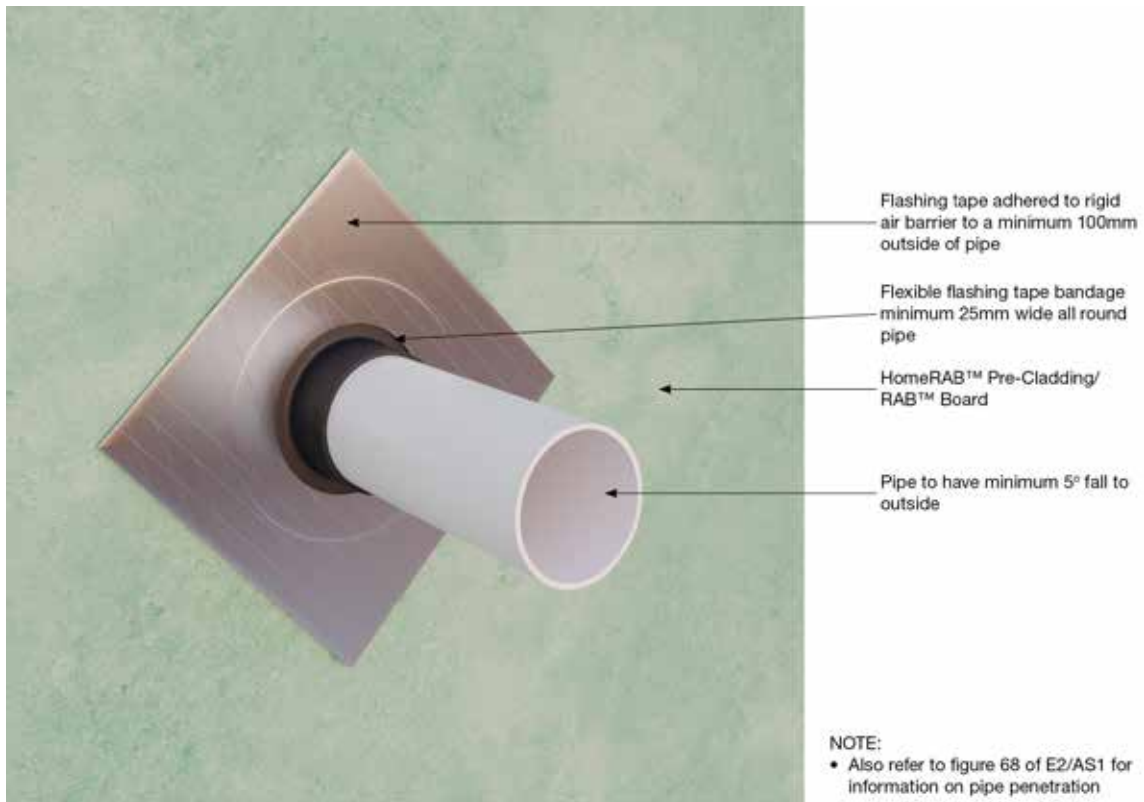

Figure 24: Flashing at balustrade

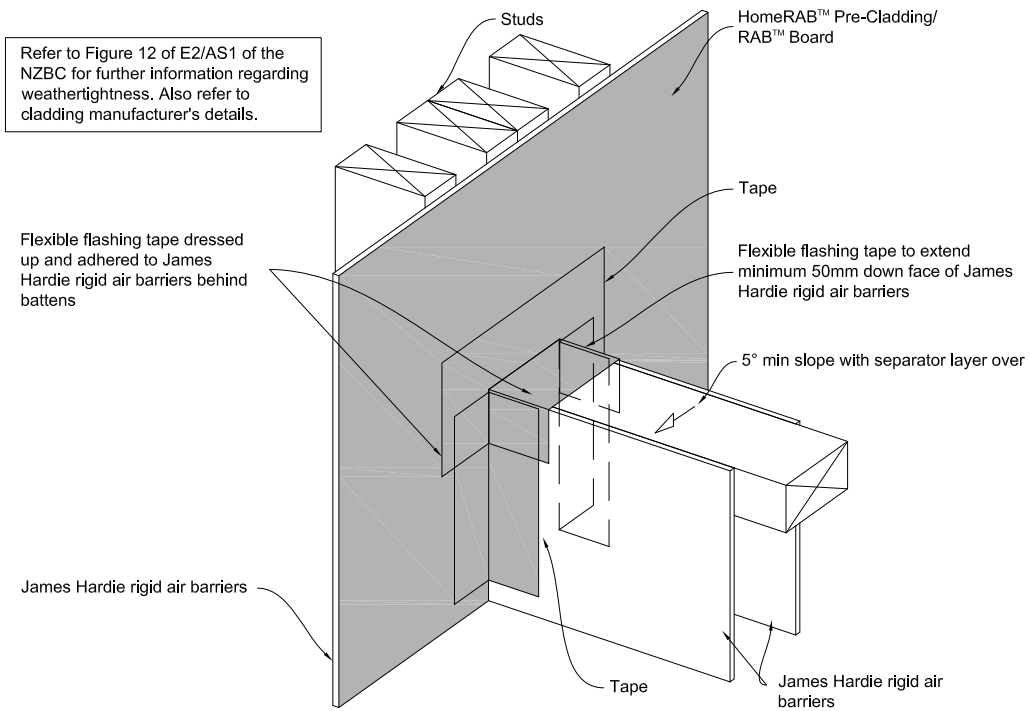
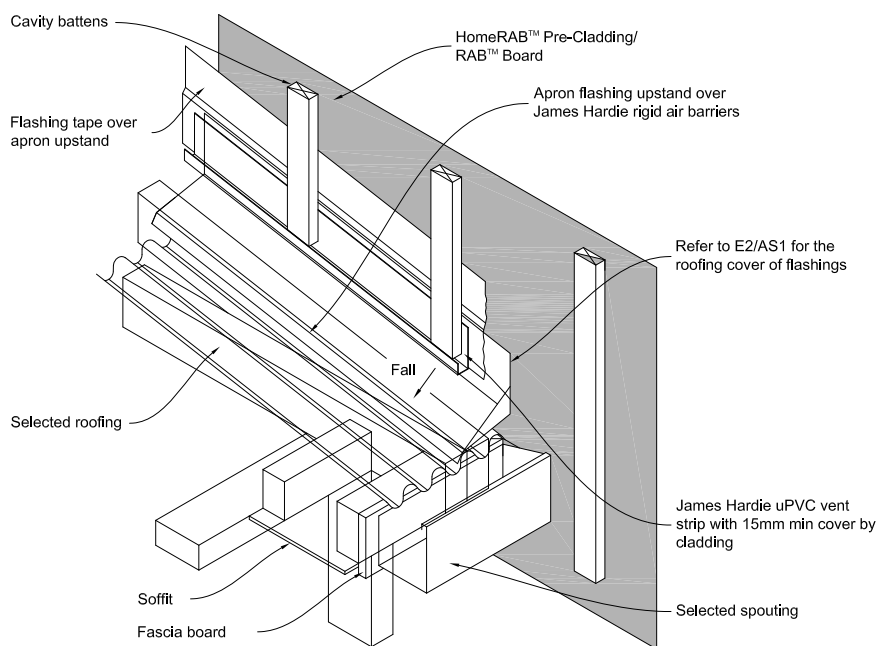

Figure 25: Apron flashing



5.3.3 Inter-storey deflections

When installing James Hardie rigid air barriers, a horizontal joint in the RAB Board must be incorporated between sheets at each floor level to accommodate for the inter-storey deflections. Refer to Figures 9 and 10.

For the specific engineering design (SED), where structures are subject to high wind pressures and designed with inter-storey

seismic deflections, the use of 6mm or 9mm RAB Board is recommended. RAB Board, when fixed as per this installation manual, is readily capable of withstanding Serviceability Limit State (SLS) deflections up to span/180. For structures where greater inter-storey seismic deflections are expected, a deflection head should be used, as per the project structural engineer's design and detailing. Refer to Figure 26.

Figure 26: Deflection head

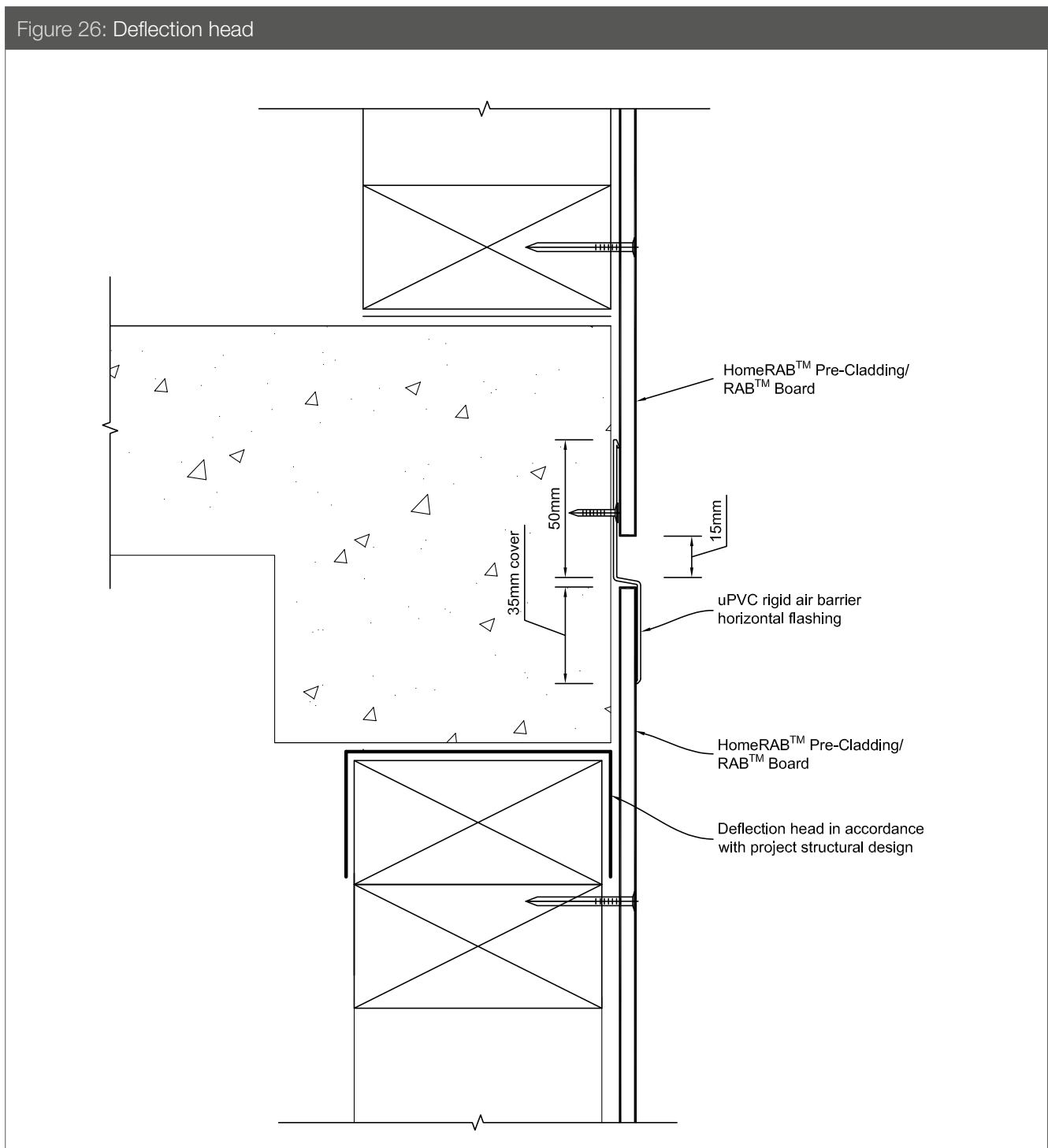

6 Bracing

James Hardie rigid air barriers are suitable for bracing applications. Given below are various bracing systems that have been tested and the bracing values published. Refer to bracing system details for bracing installation or refer to James Hardie Bracing Design Manual for further information.

6.1 BOTTOM PLATE FIXING/ HOLD DOWN RESTRAINTS

The timber framing must be fixed in accordance to table 8.19 of NZS 3604. Additional hold down restraints must be provided as per each bracing system's requirements. Refer to bracing systems details.

6.7.1 Concrete foundation

Pydra brace anchor kits or GIB Handibrac® with a 15kN minimum uplift capacity holding down bolt can be used as end restraints.

6.7.2 Timber foundation

Pydra brace anchor kits or GIB Handibrac® with a M12 x 150mm holding down bolt can be used as end restraints. Alternatively, holding down straps as per NZS 3604 can also be used.

6.2 FASTENER DURABILITY AND SIZE

Coach screws and holding down (HD) bolts, where used, must be M12 hot-dipped galvanised steel fitted with 50 x 50 x 3mm galvanised washers. The holding down bolts and washers must have a protective coating as per Table 4.2 of NZS 3604.

PRE-CLADDINGS:

All nails for fixing the pre-cladding bracing panels in Zone D must be Grade 304/316 stainless steel in accordance with NZS 3604.

All nails for fixing the pre-cladding bracing panels for Zone B and Zone C can be Grade 304/316 stainless steel or hot dipped galvanised steel nail.

Note: Fastener sizes are given in the respective details section for each product or system.

6.3 SHEET NAILING

Nails can be hand driven or gun nailed at a minimum edge distance as shown in the bracing details within this specification. This also applies to dimensions from corners, vertically and horizontally. The sheets must be held hard against the framing during nailing to minimise sheet break-out at the back of sheet. Always drive all nails flush with the sheet surface. For sheet/panel systems do not punch the nail below the surface as it reduces the nail's holding power.

Fix all sheets from the centre working towards outer edges to avoid drumminess. Fixings at 150mm maximum centres when hand nailing.

Gun nails can be used on some bracing systems with fixings at 100mm maximum centres. Must use a 6.85mm \varnothing round head coil nail with a pneumatic nail gun. **Refer to bracing tables for hand or gun nail options available.**

6.4 SHEET ORIENTATION

For the bracing systems specified in this manual, all flat sheets must be fixed vertically with the exception of Villaboard™ Lining, which can either be fixed vertically or horizontally as per the bracing systems details.

Full-height sheets must be used for walls up to 3000mm in height. When bracing walls height exceed 3000mm, sheet jointing is acceptable. Only one horizontal sheet joint is permitted within the element height. The maximum height of bracing wall is limited to 4800mm.

A site cut bracing sheet must be minimum 300mm wide when used in a bracing element. Refer to Figure 16.

Always ensure that the sheet joint is on the centre line of the stud or nog to achieve sufficient cover of fixings.

In internal walls the lining sheet used for bracing must stop 6mm above the finished floor.

6.5 SERVICE PENETRATIONS

Holes/penetrations up to 100 x 100mm positioned no closer than 200mm of the edge or another penetration, are allowed for services. Maximum of two service penetrations are recommended per sheet.

No window/door penetrations are allowed within the bracing elements.

Table 7

HomeRAB™ Pre-Cladding vertically fixed									
System number	Length	Hold down	Refer figures	BU/M		kN/m		Fixing method	
				Wind	Earthquake	Wind	Earthquake	Hand nail	Gun nail
Hpn	1200	N	27	67	71	3.4	3.6	✓	
HP	400	Y	28,32,33,34	85	91	4.3	4.6	✓	E
	600	Y	28,32,33,34	99	103	5.0	5.2	✓	E
	1200 to 2400	Y	29,32,33,34	133*	104	6.7	5.2	✓	E
	2400 to 4800	Y	29,32,33,34	141*	67	7.1	3.4	✓	E

*A limit of 120BUs/m maximum applies to timber floors and 150BUs/m maximum to concrete floors built as per NZS 3604: 2011 unless a specific engineering design is carried out to ensure the uplift force generated by bracing elements does not exceed the maximum limit for each floor type.

Table 8

HomeRAB™ Pre-Cladding vertically fixed with 10mm GIB® Standard plasterboard									
System number	Length	Hold down	Refer figures	BU/M		kN/m		Fixing method	
				Wind	Earthquake	Wind	Earthquake	Hand nail	Gun nail
HPg	400	Y	28,30,32,33,34	90	98	4.5	4.9	✓	E
	600	Y	28,30,32,33,34	127*	136*	6.4	6.8	✓	E
	1200 to 2400	Y	29,31,32,33,34	164*	138*	8.2	6.9	✓	E

*A limit of 120BUs/m maximum applies to timber floors and 150BUs/m maximum to concrete floors built as per NZS 3604: 2011 unless a specific engineering design is carried out to ensure the uplift force generated by bracing elements does not exceed the maximum limit for each floor type.

Table 9

RAB™ Board 6mm or 9mm									
System number	Length	Hold down	Refer figures	BU/M		kN/m		Fixing method	
				Wind	Earthquake	Wind	Earthquake	Hand nail	Gun nail
JHDn	1200	N	27	118	102	5.9	5.1	✓	
JHD	400	Y	28,32,33,34	83	107	4.2	5.4	✓	E & P
	600	Y	28,32,33,34	99	107	5.0	5.4	✓	E & P
	1200 to 2400	Y	29,32,33,34	154*	140*	7.7	7.0	✓	E & P
	2400 to 4800	Y	29,32,33,34	133*	150*	6.7	7.5	✓	E & P

*A limit of 120BUs/m maximum applies to timber floors and 150BUs/m maximum to concrete floors built as per NZS 3604: 2011 unless a specific engineering design is carried out to ensure the uplift force generated by bracing elements does not exceed the maximum limit for each floor type.

E = Ecko Pneumatic wireless coil nail

P = Paslode RounDrive ring shank nail

Figure 27: 1200mm HomeRAB™ Pre-Cladding or RAB™ Board to concrete or timber floor
 - no hold down brackets

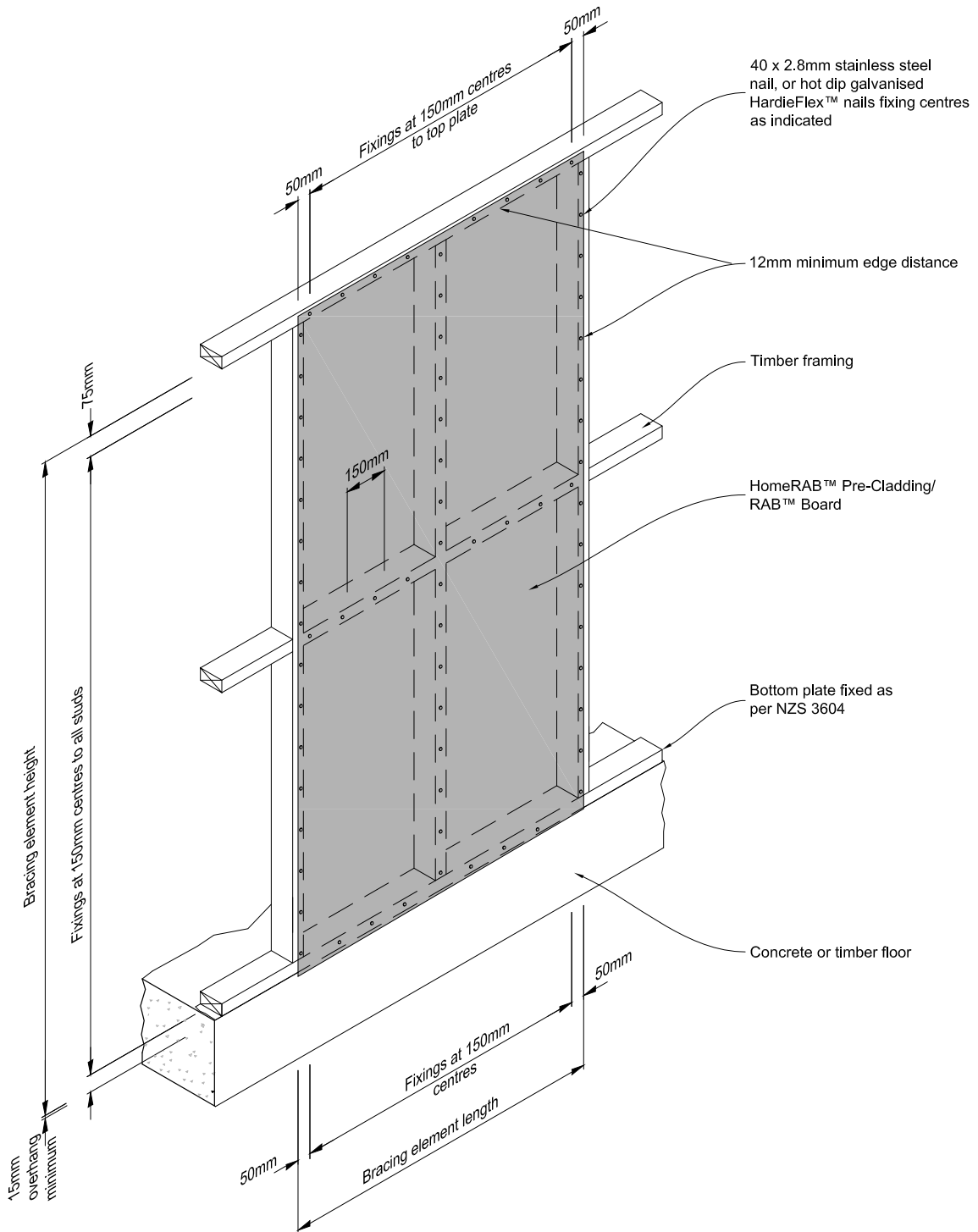

Product	System	Minimum length
HomeRAB™ Pre-Cladding	HPn	1200mm
RAB™ Board	JHDn	1200mm

Figure 28: 400/600mm HomeRAB™ Pre-Cladding or RAB™ Board to concrete or timber floor

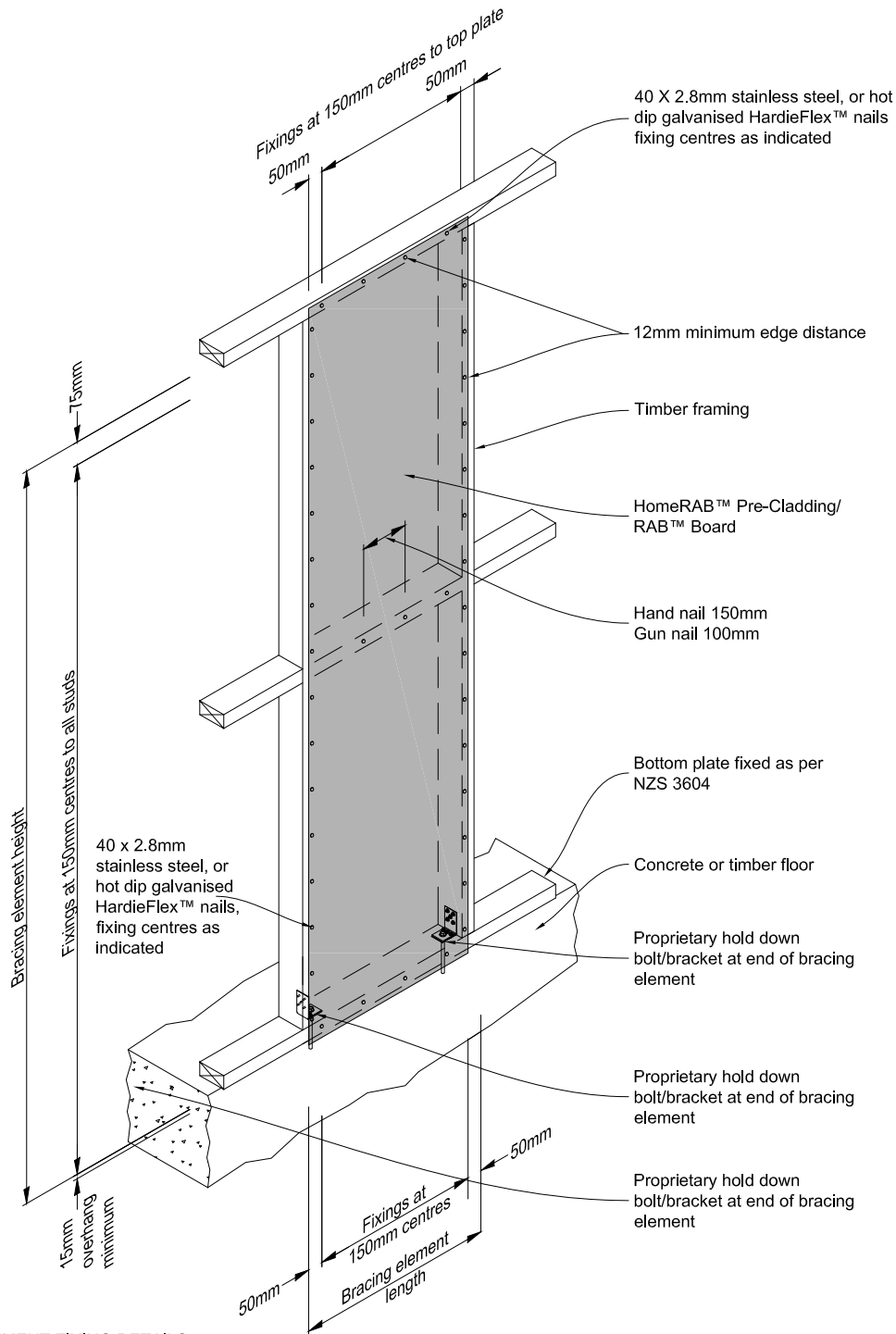

FIBRE CEMENT FIXING DETAILS

Notes for Figure 28:

- **Concrete floor** bottom plate fixing:- Ramset bracing anchor kit Concrete or GIB Handibrac® with 15kN anchor at each end of bracing element
- **Timber floor** bottom plate fixing:- Ramset bracing anchor kit Wood or GIB Handibrac® with a 12x150mm galvanised coach screw at each end of bracing element

Product	System	Minimum length
HomeRAB™ Pre-Cladding	HP	400 or 600mm
HomeRAB™ Pre-Cladding with 10mm GIB® Standard plasterboard	HPg	400 or 600mm
RAB™ Board	JHD	400 or 600mm

Figure 29: 1200mm HomeRAB™ Pre-Cladding or RAB™ Board to concrete or timber floor

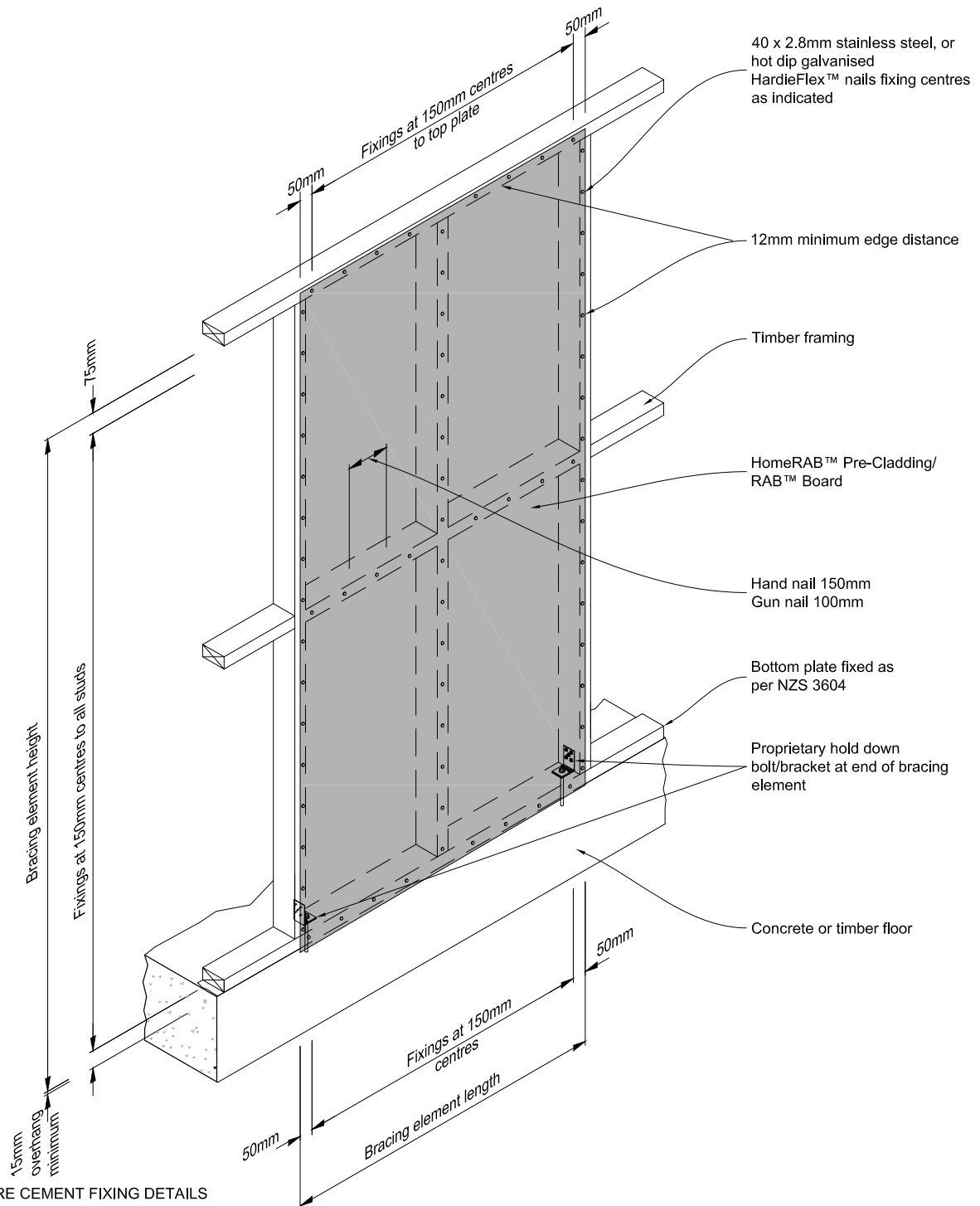

FIBRE CEMENT FIXING DETAILS

Notes for Figure 29:

- **Concrete floor** bottom plate fixing:- Ramset bracing anchor kit Concrete or GIB Handibrac® with 15kN anchor at each end of bracing element
- **Timber floor** bottom plate fixing:- Ramset bracing anchor kit Wood or GIB Handibrac® with a 12x150mm galvanised coach screw at each end of bracing element

Product	System	Minimum length
HomeRAB™ Pre-Cladding	HP	1200mm
HomeRAB™ Pre-Cladding with 10mm GIB® Standard plasterboard	HPg	1200mm
RAB™ Board	JHD	1200mm

Figure 30: 400mm/600mm HomeRAB™ Pre-Cladding with 10mm GIB® Standard Plasterboard

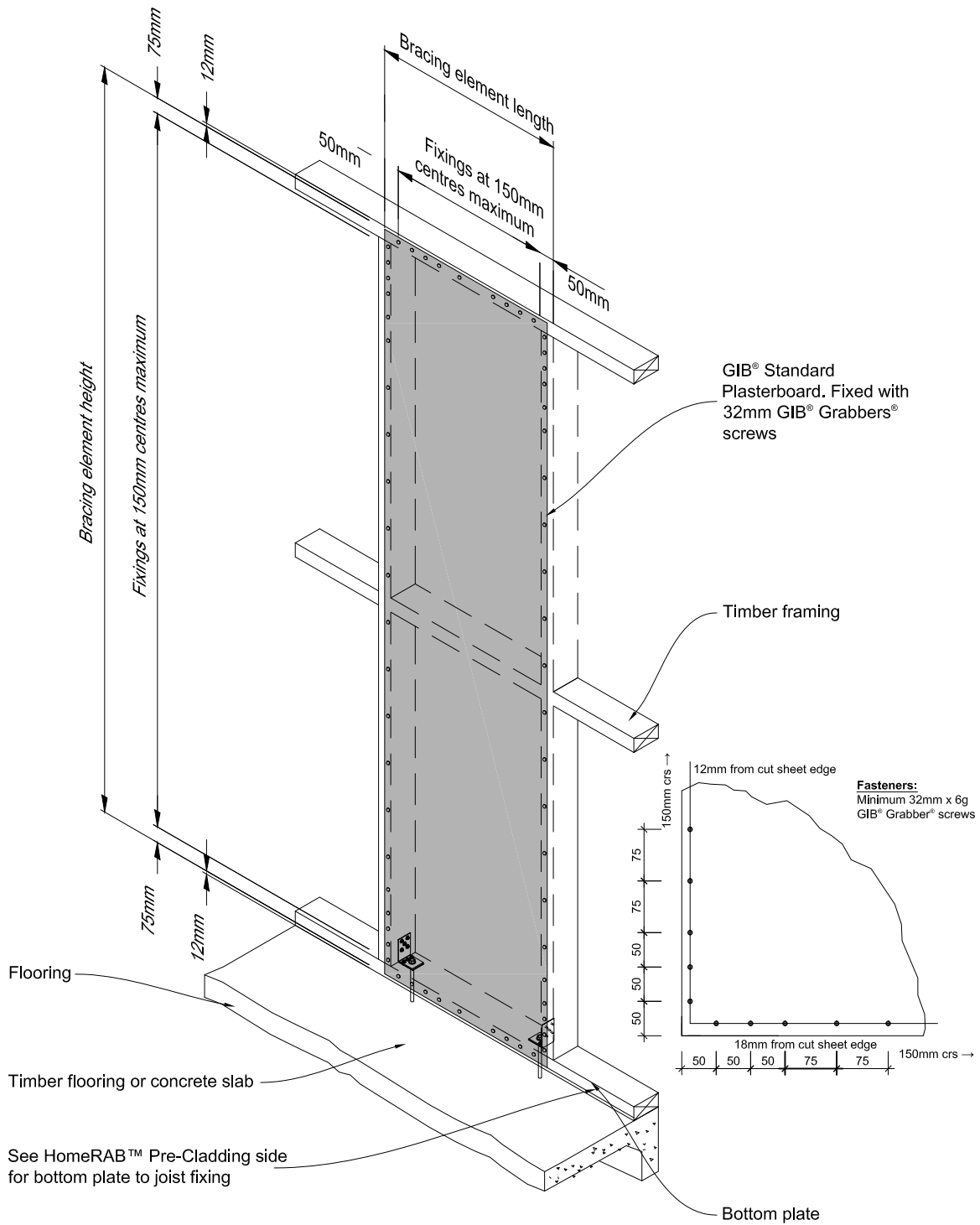

STANDARD GIB® FIXING DETAILS

Notes for Figure 30:

- All GIB® standard sheets to be fixed to Winstone Wallboards Ltd specifications. GIB® Bracing Systems.
- All GIB® bracing sheets to be stopped to Winstone Wallboards Ltd specifications. GIB® Site Guide.
- Refer Winstone Wallboards Ltd specifications for edge distance.

Product	System	Minimum length
HomeRAB™ Pre-Cladding	HPg	400 or 600mm

Figure 31: 1200mm HomeRAB™ Pre-Cladding with 10mm GIB® Standard Plasterboard

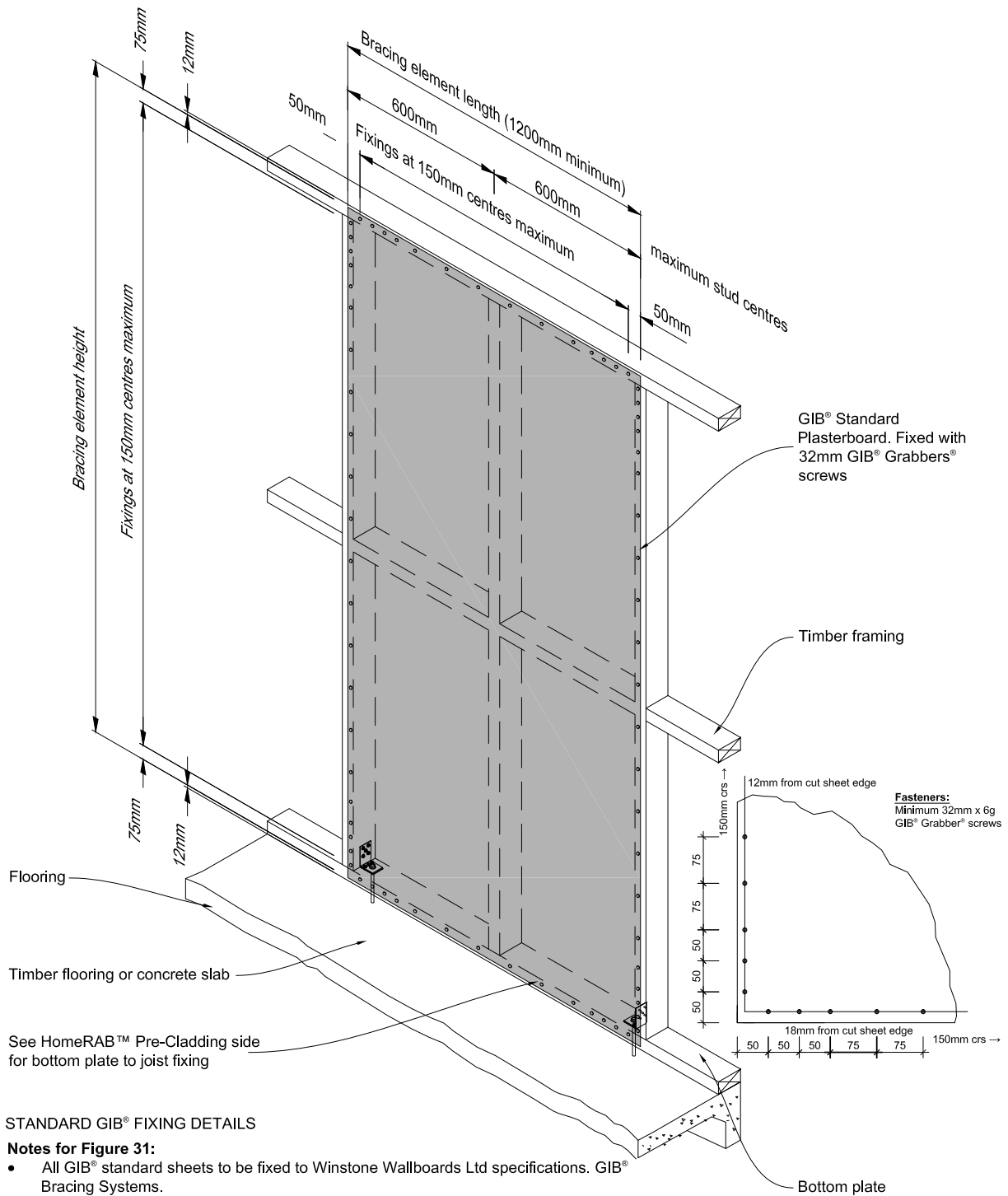

STANDARD GIB® FIXING DETAILS

Notes for Figure 31:

- All GIB® standard sheets to be fixed to Winstone Wallboards Ltd specifications. GIB® Bracing Systems.
- All GIB® bracing sheets to be stopped to Winstone Wallboards Ltd specifications. GIB® Site Guide.
- Refer Winstone Wallboards Ltd specifications for edge distance.

Product	System	Minimum length
HomeRAB™ Pre-Cladding/GIB® Standard Plasterboard	HPg	1200mm

Bracing Construction Figures

Figure 32: End bracket to concrete slab

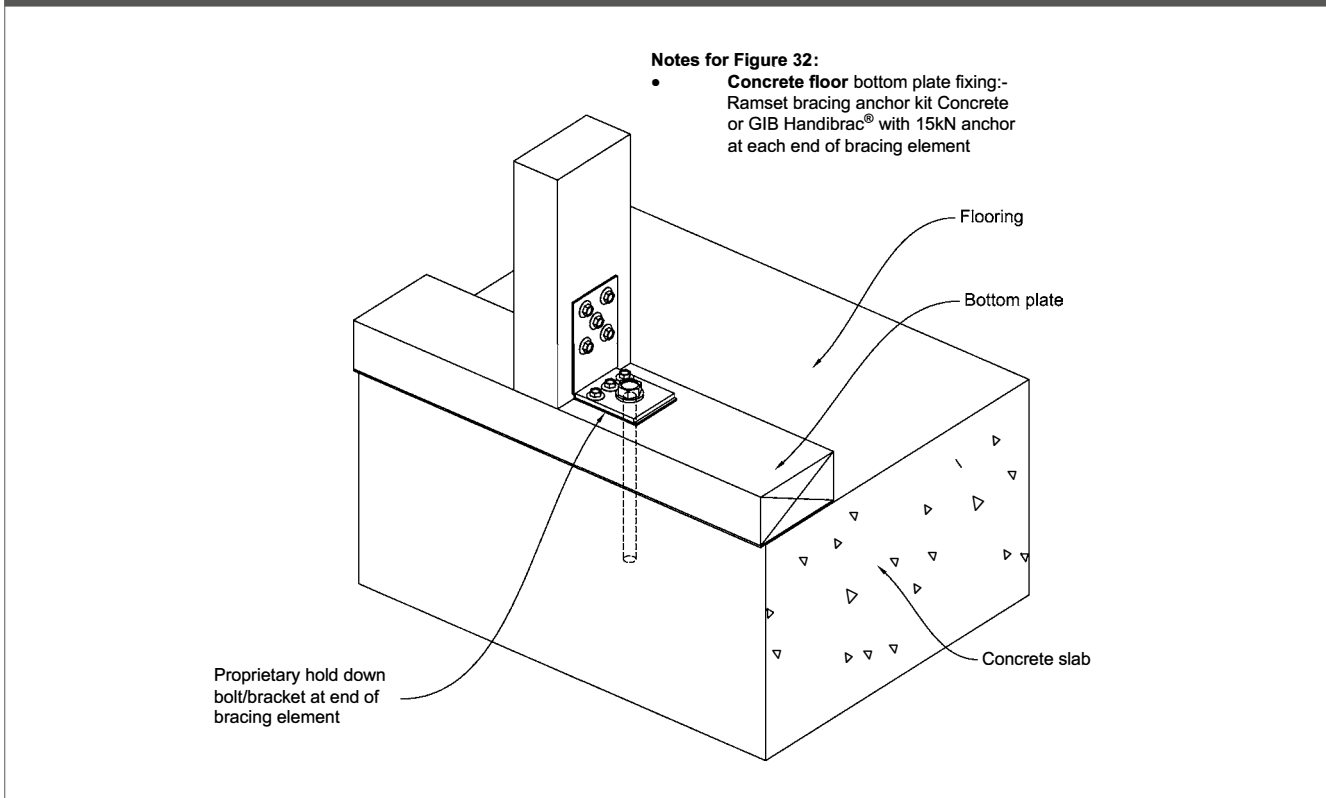

Figure 33: End bracket to timber joist

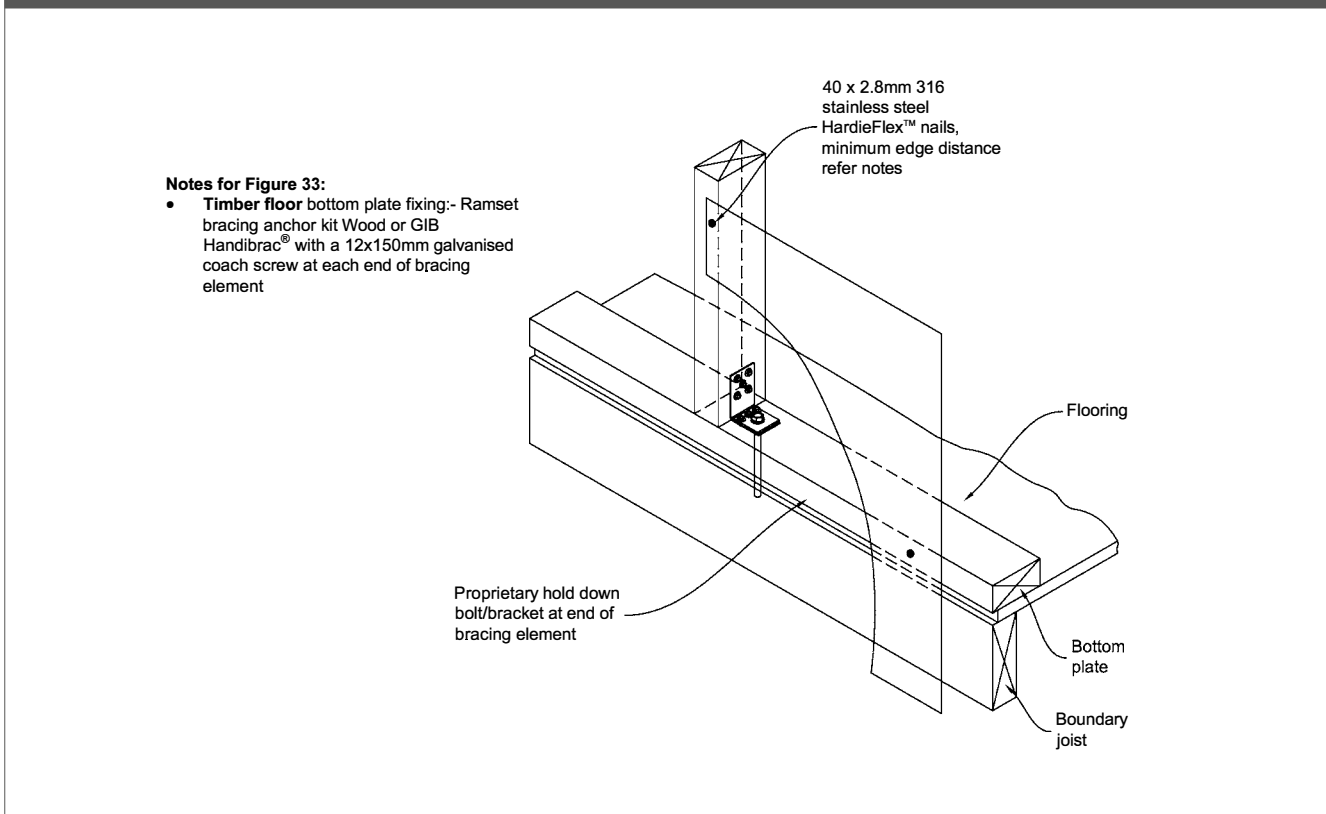
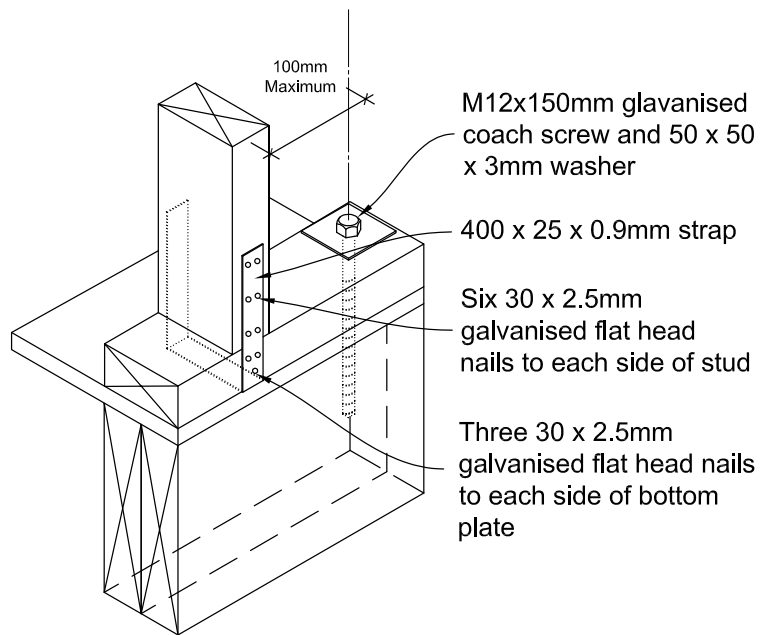
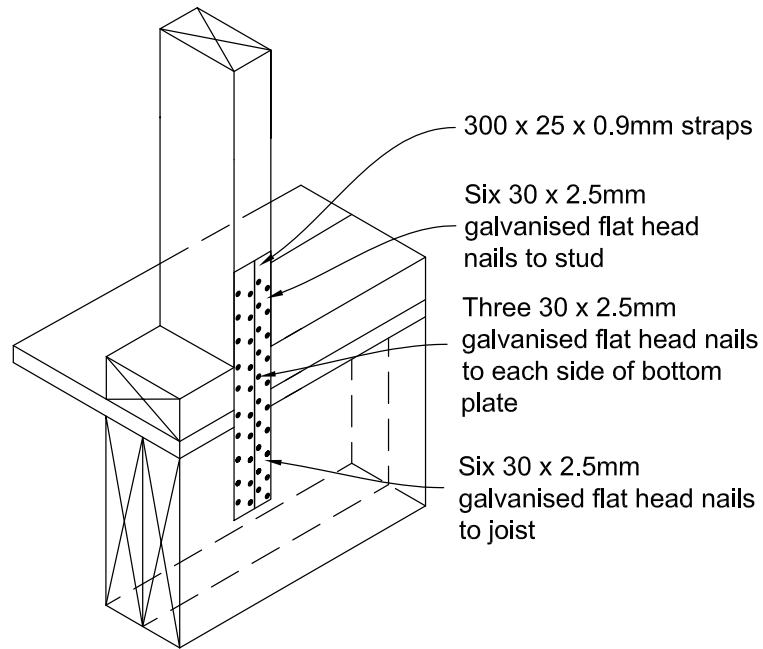

Figure 34: Hold down straps to timber joists



7 Product information

7.1 GENERAL

HomeRAB Pre-Cladding and RAB Board are cellulose fibre reinforced cement building products. The basic composition is Portland cement, ground sand, cellulose fibre and water.

RAB Board is easily identified by the name RAB Board printed on the back face. It has a green colour water repellent sealer applied on its front face.

HomeRAB Pre-Cladding is easily identified by the name 'HomeRAB Pre-Cladding' on the front face. It has a green colour water repellent sealer applied on its front face. The name is also printed on the back face of the lining.

HomeRAB Pre-Cladding and RAB Board are manufactured to conform to the requirements of AS/NZS 2908.2 'Cellulose-Cement Products Part 2: Flat Sheet (ISO 8336).

HomeRAB Pre-Cladding and RAB Board are classified Type B, Category 3 in accordance with AS/NZS 2908.2.

For Safety Data Sheets (SDS) visit www.jameshardie.co.nz or Ask James Hardie on 0800 808 868.

7.2 DURABILITY

Resistance to moisture/rotting

James Hardie rigid air barriers have been assessed for permanent moisture induced deterioration (rotting) and have met the performance requirements of AS/NZS 2908.2.

Resistance to fire

James Hardie rigid air barriers have been tested/assessed and are classified as Non-Combustible Material.

7.3 ALPINE REGIONS

In regions subject to freeze/thaw conditions, James Hardie rigid air barriers must not be in direct contact with snow or ice build up e.g. external walls in alpine regions subject to snow drifts over winter. James Hardie rigid air barriers have been tested to resist freeze thaw in accordance with AS/NZS 2908.2 clause 8.2.3 requirements and is suitable for use in alpine regions.

8 Finishes and maintenance

The selected cladding must be installed and finished within 180 days after the installation of James Hardie rigid air barriers, and the cladding must comply with the requirements of the NZBC. Regular cleaning and maintenance of claddings paints, joints, junctions, penetrations, flashings etc must be carried out at regular intervals and as per the requirements of the material manufacturers. Regular maintenance of cladding is also a requirement under the NZBC.

The ground clearances required for the James Hardie rigid air barriers and the cladding must always be maintained.

Notes

A series of horizontal dotted lines for taking notes.

Notes

A series of horizontal dotted lines for taking notes.

Product Warranty

HomeRAB™
PRE-CLADDING



RAB™
BOARD



James Hardie New Zealand Limited ("James Hardie") warrants for a period of 15 years from the date of purchase that the HomeRAB™ Pre-Cladding/RAB™ Board (the "Product"), will be free from defects due to defective factory workmanship or materials and, subject to compliance with the conditions below, will be resistant to cracking, rotting, fire and damage from termite attacks to the extent set out in James Hardie's relevant published literature current at the time of installation. James Hardie warrants for a period of 15 years from the date of purchase that the accessories supplied by James Hardie will be free from defects due to defective factory workmanship or materials. Nothing in this document shall exclude or modify any legal rights a customer may have under the Consumer Guarantees Act or otherwise which cannot be excluded or modified at law.

CONDITIONS OF WARRANTY:

The warranty is strictly subject to the following conditions:

- a) James Hardie will not be liable for breach of warranty unless the claimant provides proof of purchase and makes a written claim either within 30 days after the defect would have become reasonably apparent or, if the defect was reasonably apparent prior to installation, then the claim must be made prior to installation;
- b) this warranty is not transferable;
- c) the Product must be installed and maintained strictly in accordance with the relevant James Hardie literature current at the time of installation and must be installed in conjunction with the components or products specified in the literature. Further, all other products, including coating and jointing systems, applied to or used in conjunction with the Product must be applied or installed and maintained strictly in accordance with the relevant manufacturer's instructions and good trade practice;
- d) the project must be designed and constructed in strict compliance with all relevant provisions of the current New Zealand Building Code ("NZBC"), regulations and standards;
- e) the claimant's sole remedy for breach of warranty is (at James Hardie's option) that James Hardie will either supply replacement product, rectify the affected product or pay for the cost of the replacement or rectification of the affected product;
- f) James Hardie will not be liable for any losses or damages (whether direct or indirect) including property damage or personal injury, consequential loss, economic loss or loss of profits, arising in contract or negligence or howsoever arising. Without limiting the foregoing James Hardie will not be liable for any claims, damages or defects arising from or in any way attributable to poor workmanship, poor design or detailing, settlement or structural movement and/or movement of materials to which the Product is attached, incorrect design of the structure, acts of God including but not limited to earthquakes, cyclones, floods or other severe weather conditions or unusual climatic conditions, efflorescence or performance of paint/coatings applied to the Product, normal wear and tear, growth of mould, mildew, fungi, bacteria, or any organism on any Product surface or Product (whether on the exposed or unexposed surfaces);
- g) all warranties, conditions, liabilities and obligations other than those specified in this warranty are excluded to the fullest extent allowed by law;
- h) if meeting a claim under this warranty involves re-coating of Products, there may be slight colour differences between the original and replacement Products due to the effects of weathering and variations in materials over time.

Disclaimer: The recommendations in James Hardie's literature are based on good building practice, but are not an exhaustive statement of all relevant information and are subject to conditions (c), (d), (f) and (g) above. James Hardie has tested the performance of the HomeRAB™ Pre-Cladding/RAB™ Board when installed in accordance with the HomeRAB™ Pre-Cladding/RAB™ Board installation manual in accordance with the standards and verification methods required by the NZBC and those test results demonstrate the product complies with the performance criteria established by the NZBC. However, as the successful performance of the relevant system depends on numerous factors outside the control of James Hardie (e.g. quality of workmanship and design) James Hardie shall not be liable for the recommendations made in its literature and the performance of the relevant system, including its suitability for any purpose or ability to satisfy the relevant provisions of the NZBC, regulations and standards, as it is the responsibility of the building designer to ensure that the details and recommendations provided in the relevant James Hardie installation manual are suitable for the intended project and that specific design is conducted where appropriate.

Copyright April 2019. © James Hardie New Zealand Limited. TM and ® denotes a Trademark or Registered Mark owned by James Hardie Technology Limited.

Ask James Hardie™ | Call 0800 808 868 | jameshardie.co.nz



