

# INSTALLATION INSTRUCTIONS

# ACRYLIC BATH

Please read these instructions carefully. Incorrect installation could nullify your warranty.

## IMPORTANT

ALL INSTALLATIONS MUST COMPLY WITH COUNCIL AND LOCAL AUTHORITY BY-LAWS.  
IT IS THE RESPONSIBILITY OF THE INSTALLER TO ENSURE THAT THE WASTE IS MADE WATERTIGHT BY MEANS OF SILICONE SEALANT OR CAULKING COMPOUND.

1. Your new bath has been manufactured to the highest possible standards. However please inspect for any possible damage that may have occurred in transit.

**NOTE: Warranty does not cover damage to bath caused in transit or installation.**

2. The protective film must be removed from around the waste and along the tiling bead prior to installation in order to make a watertight seal at these points possible.

### 3. POP -UP WASTE WITH OVERFLOW INSTALLATION.

If the unit is fitted with a waste/overflow, please ensure that the bath is placed on wooden blocks or bricks to protect the waste body under the bath.

For installation follow manufacturer instructions.

Remember to plan for access panels to simplify further service intervention to waste and overflow fitting when required.

### 4. BATH INSTALLATION

Locate the bath in the proposed position.

#### IMPORTANT

The bath must be installed level on all top edges.  
The rim and the base of the bath must be fully supported.

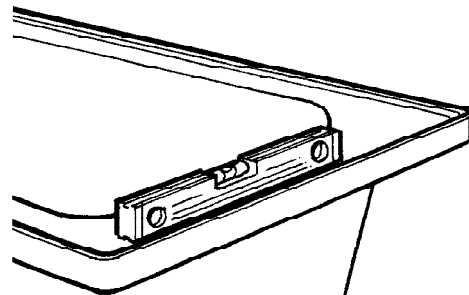

#### 4a. BASE SUPPORT-METHOD A

Floor should be flat, level and free of any bumps and protrusions.

The base of the bath must be fully supported.

If the bath has support feet, ensure they are fully supported. Do not hang the bath by the rim.

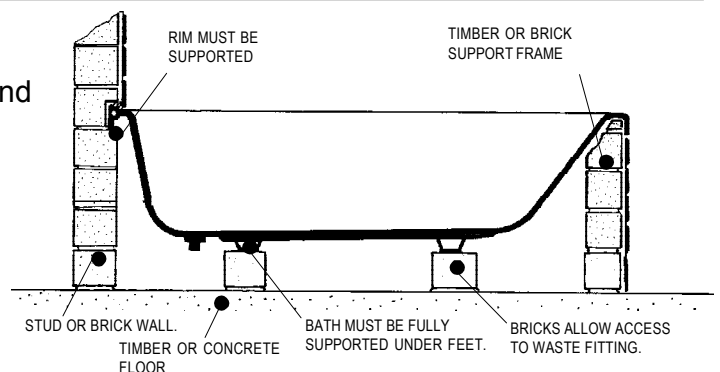

#### BASE SUPPORT-METHOD B

Install the bath in a bed of weak mortar slurry mix (6:1) ensuring the base is fully supported.

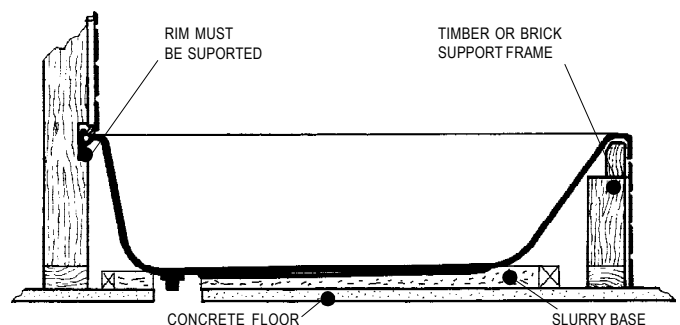

## 4b. RIM SUPPORT

Ensure that the bath rim is fully supported.

Build the bath support frame as shown in the relevant diagram below.

### BRICK CONSTRUCTION

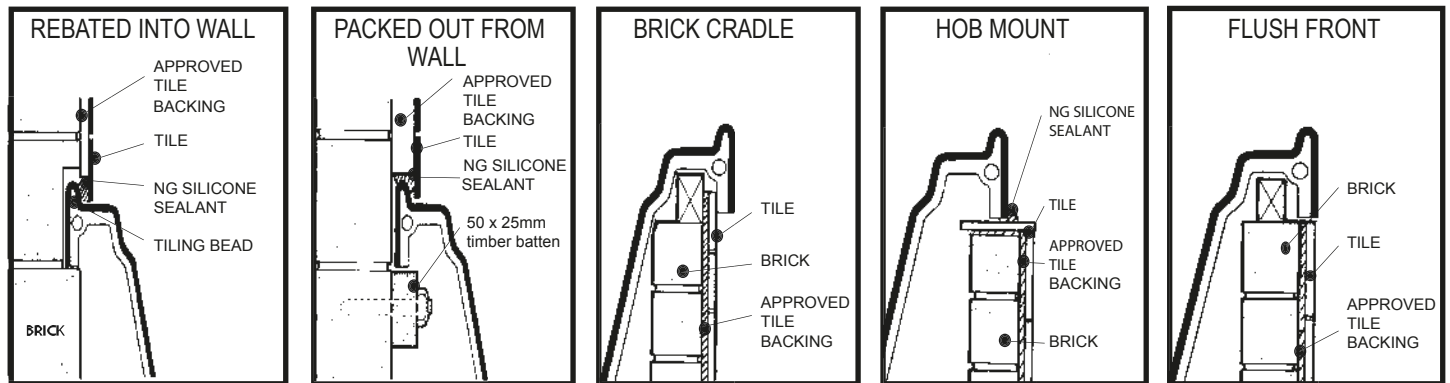

### TIMBER CONSTRUCTION

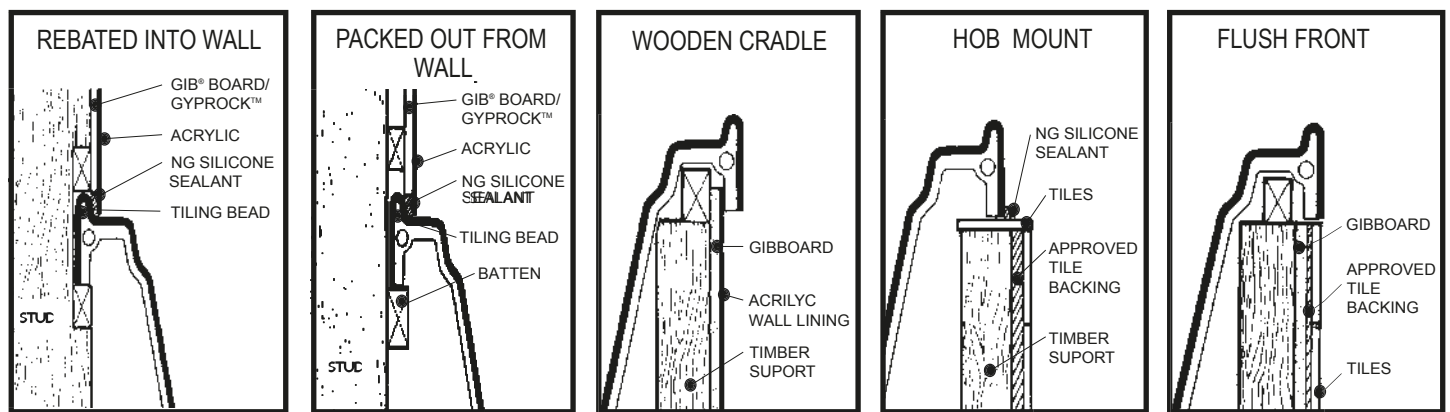

When the bath is securely positioned and before the unit is fully built in, install tapware and connect plumbing to tapware and waste fitting.

Run water into the bath and check connections for leaks.

Plan for access panels to simplify further access to waste, overflow and tapware.

## CONTACT AND WARRANTY INFORMATION

### CALL US FOR HELP

# KOHLER

#### NEW ZEALAND

KOHLER NZ LTD  
Tel: 0800 564 537  
Fax: 0800 664 488  
www.kohler.co.nz

#### AUSTRALIA

KOHLER CO  
Tel: 1800 KOHLER  
(1800 564 537)  
www.au.kohler.com

For warranty information please visit our websites

**Australia**  
www.au.kohler.com

**New Zealand**  
www.kohler.co.nz

### CALL US FOR HELP



#### NEW ZEALAND

KOHLER NZ LTD  
Tel: 0800 100 382  
Fax: 0800 664 488  
www.Englefield.co.nz

#### AUSTRALIA

KOHLER CO  
Tel: 1800 ENGLEFIELD  
(1800 364 533)  
www.Englefield.com

For warranty information please visit our websites

**Australia**  
www.Englefield.com.au

**New Zealand**  
www.Englefield.co.nz

# SPA PUMP INSTALLATION AND OPERATING GUIDE

## GENERAL

- It is critical that these instructions are read in full before starting an installation. Failure to do so may result in a sub standard and non warrantable installation
- Electrical circuits must be installed by a registered electrician.
- These instructions contain important installation, operating and warranty information. After installation please leave these instructions for the consumer.
- Access to power connections must be provided and must comply with local authority regulations.

## ELECTRICAL CONNECTION

The power requirements for the spa system power pack are 10 amps. Plug into a 3 pin socket protected by an earth leakage circuit breaker (ELCB), or a residential current device (RCD).

For maximum safety, ensure that the ELCB or RCD has a trip current of 30 milliamps / 30 milliseconds with a max current rating of 10 amps.

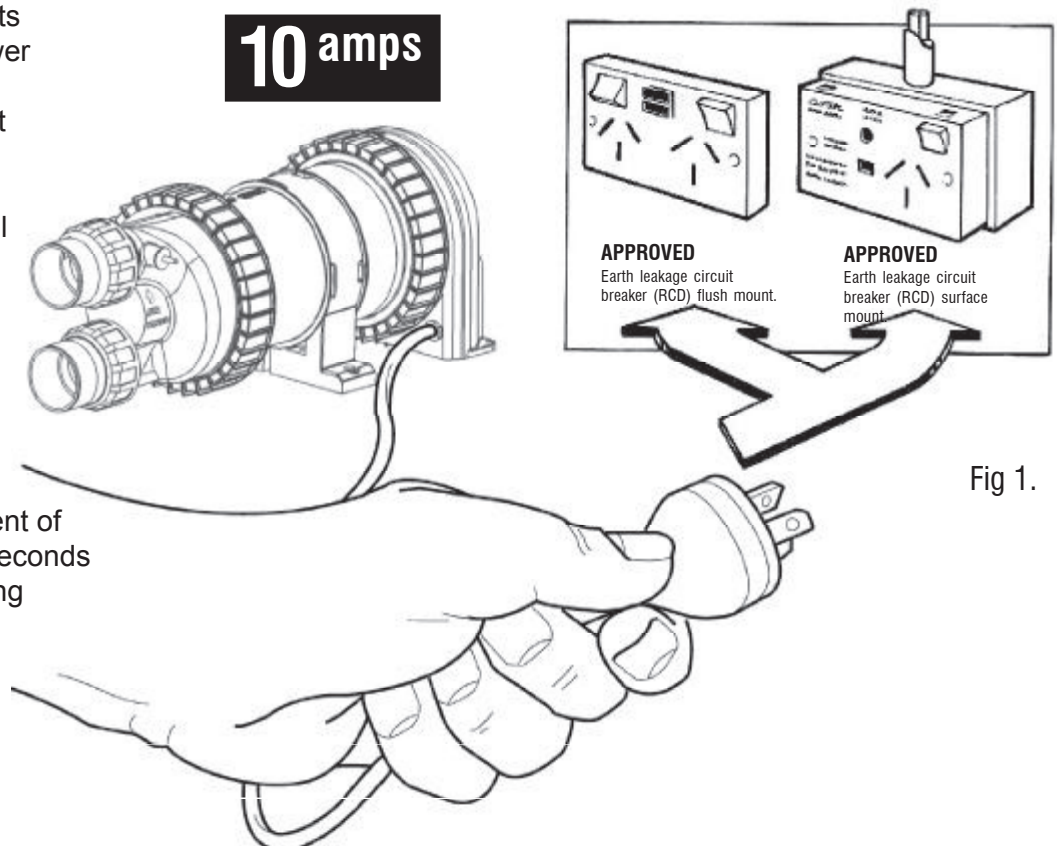

### IMPORTANT

THE ABOVE UNITS MUST BE  
CONNECTED BY A  
REGISTERED ELECTRICIAN

### IMPORTANT

ACCESS TO POWER CONNECTIONS  
MUST BE PROVIDED AND MUST  
COMPLY WITH LOCAL AUTHORITY  
REGULATIONS

## PUMP INSTALLATION

Depending on the type of spa that you have ordered you will be required to complete 1 of the 3 types of installation as outlined below.

Your spa has been factory water tested, however we recommend that prior to installation you fill the spa with water and check for any leaks that may have developed due to movement in transit.

### 1) FACTORY ATTACHED PUMP INSTALLATION (full warranty)

Your new spa has been supplied with the pump connected to the plumbing ready to be used.

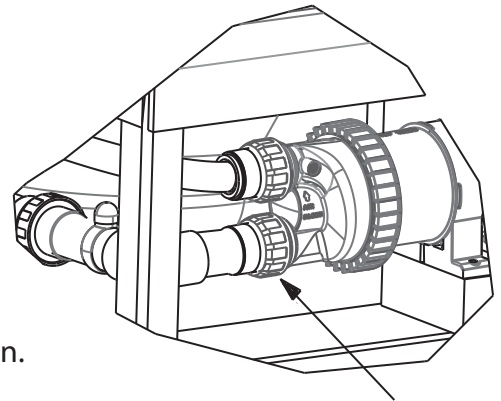
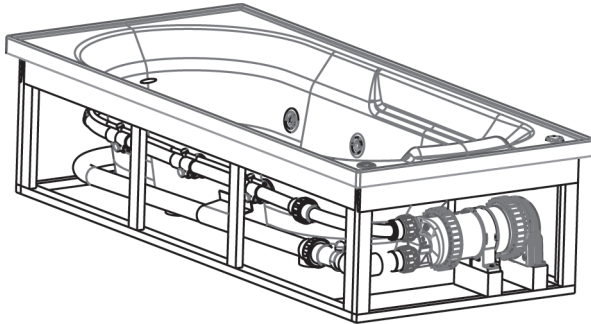

- (a) Connect the pump to an appropriate electrical supply.
- (b) Check the pump mac unions are hand tight.
- (c) Water test the product for leaks.
- (d) Do not remove the pump from its factory attached position.

Check mac unions

### 2) FACTORY ATTACHED DECOUPLED PUMP INSTALLATION (limited warranty)

Your new spa has been supplied with a mounting position and all the plumbing connections required to complete the spa installation. You should have received a spa, and boxed pump with your delivery.

Spa

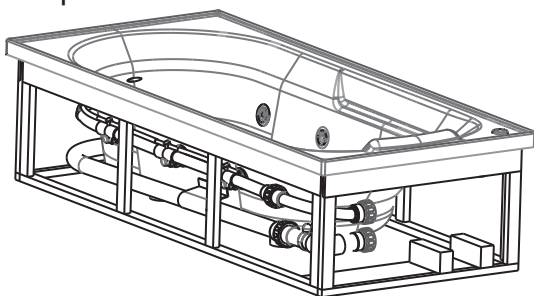

Boxed pump

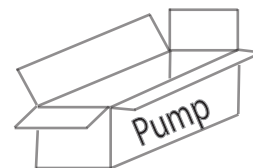

- (a) Connect the pump to the plumbing mac unions ensuring the o-rings are in place. The pump should sit on the factory positioned mount.

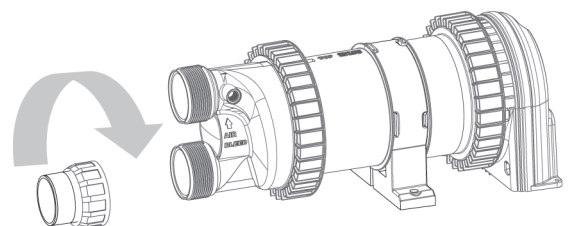
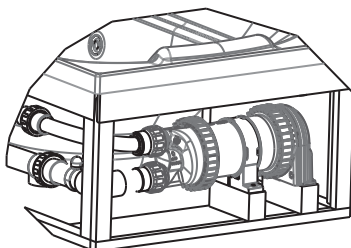

- (b) Mount and fasten the pump onto the supplied bracket using a wood screw.

Fasten screw here

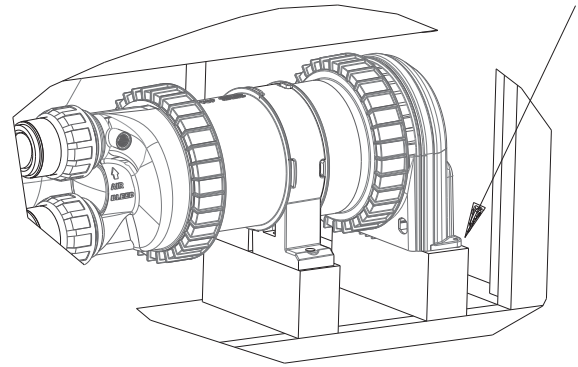

- (c) Mount the electronic touch pad or air button in the hole provided on the bath. Seal the joint with silicon and connect the switch to the pump.

Electronic touchpads should be firmly taped in place while the silicon sets.

Silicon under switch to seal

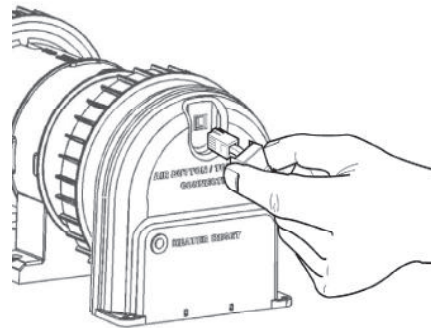
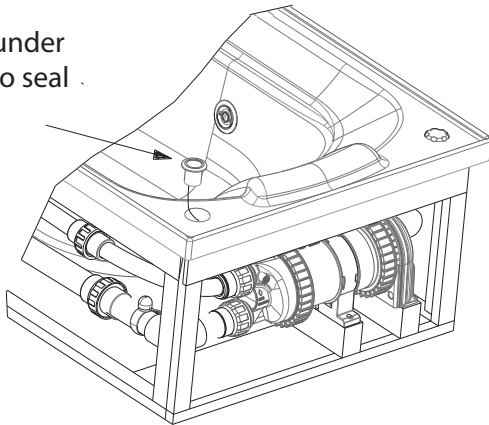

Plug electronic touchpad cord into pump

Air buttons will have a lock nut that can be tightened to hold the switch in place while the silicon sets.

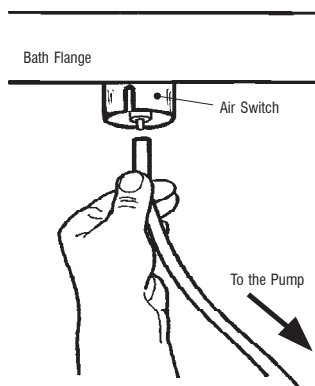

Plug air tube into the nipple on the switch

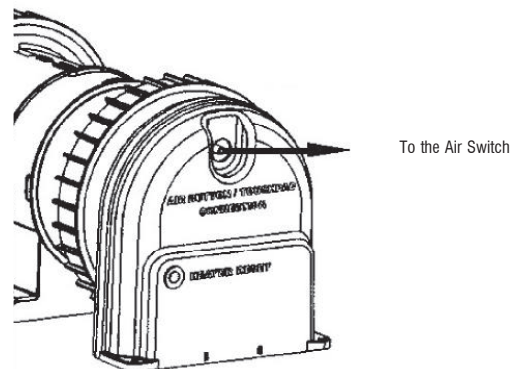

Plug air tube into the nipple on the pump

- (d) Water test the product, by filling the spa with water and inspecting for leaks.

### 3) DETACHED PUMP INSTALLATION (limited warranty)

Your spa has been supplied ready for the pump to be installed in a remote location at your discretion. Follow the guidelines below to ensure optimum spa performance.

It is the installers responsibility to ensure the pump installation is in accordance with the manufacturers instructions.

You will have recieved a plumbed spa and a boxed pump.

Spa

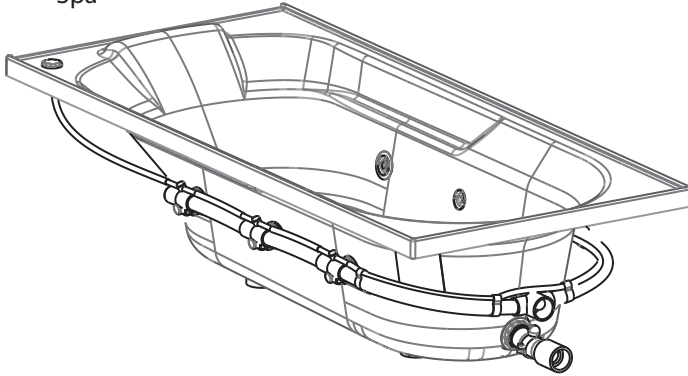

Boxed pump

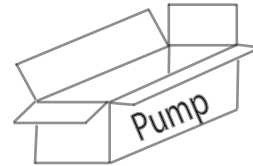

The detached pump option allows a variety of pump position installation options. Two typical detached installations are shown below.

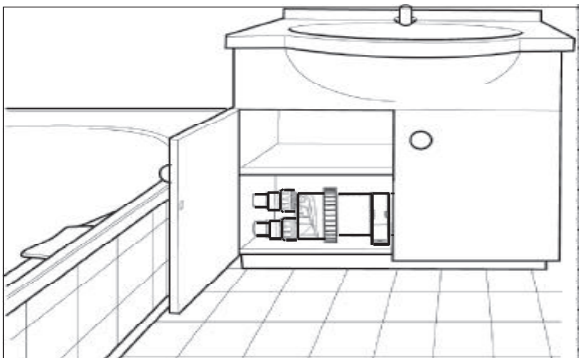

1) Interior installation - Inside a vanity cupboard

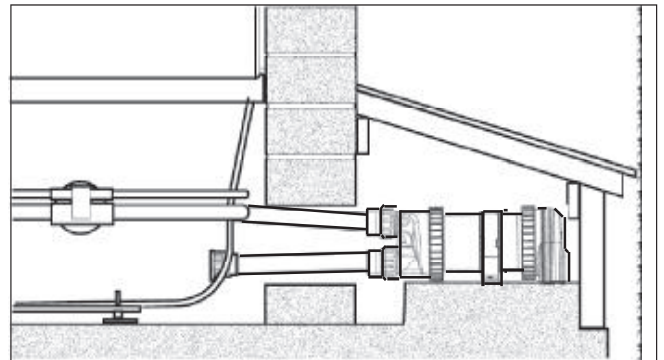

2) Exterior installation in a pump house

#### **NOTE: KEEP PUMP MOTOR DRY-WATER DAMAGE VOIDS WARRANTY**

A plumber is required to complete the plumbing of the detached installation. When plumbing the pump, fall from the pump suction inlet must be provided in order to allow the pump to drain when the spa is emptied. This ensures the system remains clean and hygienic.

Correct pump installation

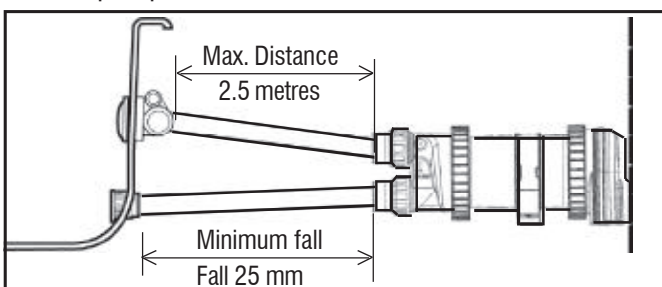

Incorrect pump installation

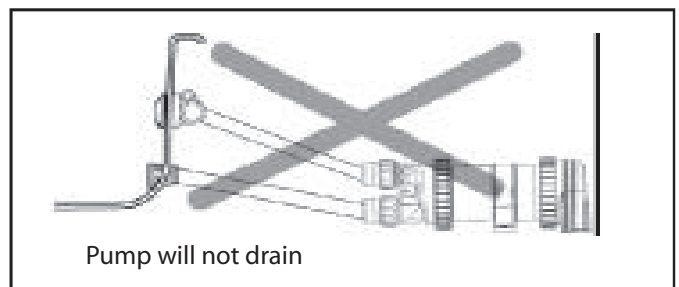

Under no circumstances is the pump suction to be installed below the level of the bath suction inlet



## ELECTRONIC SWITCH FUNCTION AND OPERATION

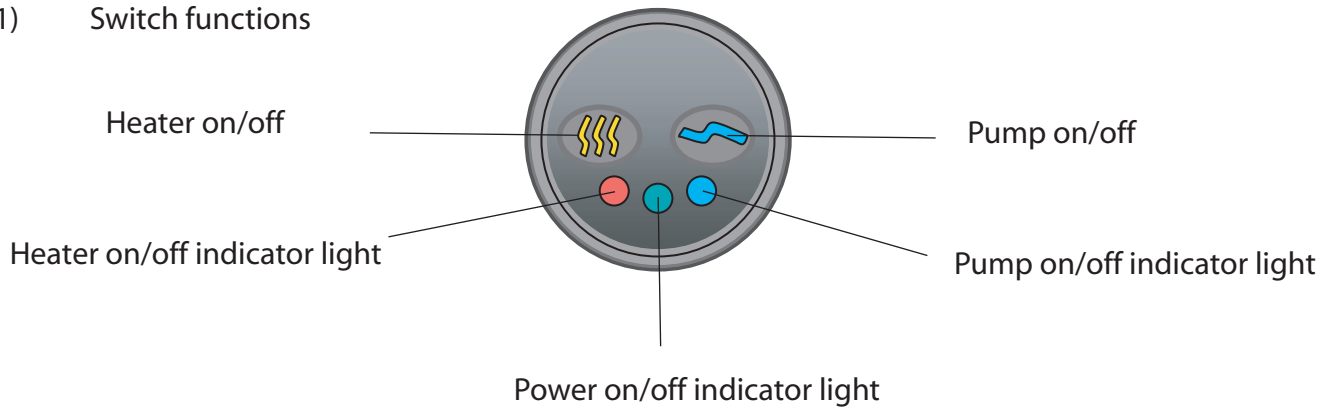

### 1) Switch functions



### 2) Switch operation

## IMPORTANT

**DO NOT OPERATE SPA BATH WITHOUT WATER**

- (a) fill bath with water and turn on power to spa - power indicator will turn on
- (b) 1st push of pump on/off button  - pump turns on and heater turns on
- (c) 1st push of heater on/off button  - heater turns off
- (d) 2nd push of pump on/off button  - pump turns off and heater turns off
- (d) drain bath of water - power indicator will remain on
- (e) turn off power to spa - power indicator will turn off

## AIR SWITCH OPERATION

- 1) Push the switch once to start the pump and once to stop the pump. The heater will automatically start when the pump is activated and is thermostatically controlled to maintain the water temperature while the spa is operating.

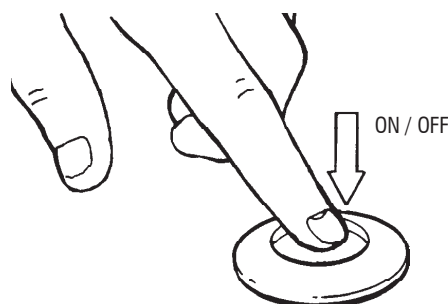

## SPA CONTROLS FUNCTION AND OPERATION

Note that not all spas are fitted with all types of controls

### AIR MASSAGE CONTROLS

Turn the air massage knob to adjust the intensity of the air bubbles that are injected into the spa.

Some spas are fitted with multiple air massage knobs to allow different regions of the spa to be controlled independently.

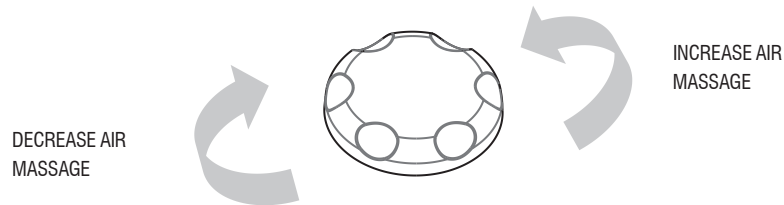

### BACK JET DIVERTER CONTROLS

Turn the back jet water diverter lever to reduce the intensity of water flow to the back jet region.

Some back jets will also have independent water flow control allowing the water flow across the back and lumbar region to be personalised.



## TECHNICAL SPECIFICATION

All electronic touchpad and airswitch spas are fitted with either C200 or C270 celsior pumps.

Pump model (A, AB, TB)	C200	C270
Voltage (V)	220-250	220-250
Supply frequency (HZ)	50	50
Motor start current (A)	6.8	12.2
Motor run current (A)	3	3.9
Motor input power (W)	690	930
Flow rate (l/min)	200	270
Phase	single	single
Enclosure class (IP)	56	56
Insulation class	F	F
Heat Booster Pumps (AB,TB)	C200AB, C200TB	C270AB, C270TB
Heater current (A)	4.2	4.2
Total unit current (A)	7.2	8.1
Heater input power (W)	1000	1000



# TROUBLE SHOOTING GUIDE

PROBLEM	CHECK IF	FIX
Spa will not turn on ( No power light on touch pad and pump will not pump water)	Power is connected Fuse at switch board has not blown RCD has not tripped Power is available at the electrical outlet. (run an electrical appliance) Electronic touchpad spas only - electronic cable from touch pad is plugged into pump Air switch spas only - air tube is connected between air switch and pump Air switch spas only - there is a build up of water in the air tube Electronic touchpad is defective	Connect the power Replace the fuse Reset the rcd Restore power to outlet Re connect the electronic touchpad cable Re connect the air switch tube Disconnect and drain the air switch tube Try a replacement electronic touchpad
Spa will not turn on ( touchpad power light on , and power is available) The pump turns on but then cuts out	The motor pump is overheating There is a power failure There is a lose power connection if pump is damaged if pump has been correctly installed (detached versions) The water temperature has exceeded 50°C There is a thermostat malfunction There is thermostat malfunction	Ensure good cool air flow around pump Restore power to the pump Fix power connections Contact the help desk Change pump position to be lower so that pump primes correctly Reset the heater by pressing the reset button on the rear cover of the pump Reset the heater by pressing the reset button on the rear cover of the pump Reset the heater by pressing the reset button on the rear cover of the pump
Pump turns on and hums but does not pump water		Call the help desk to discuss possible pump type upgrade
The pump turns on but the heater cuts out		Remove mac unions, check orings are correctly placed and re connect unions.
The pump does not heat the water		
The pump connections are leaking water		

## SERVICE

Please check the “trouble shooting guide” on the previous page before a service agent is called.

If the unit is still not operating properly advise your local merchant or distributor from whom you purchased your spa bath.

It is important to give the following information :

- (a) Warranty Number (located on pump)
- (b) Bath type
- (c) Date of purchase
- (d) Details of complaint
- (e) Name of installer

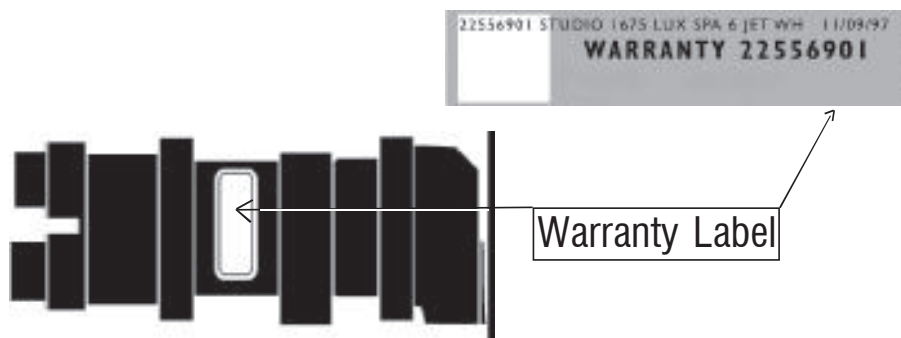

On no account does warranty cover the removal or replacement of any panels or surrounds necessary to enable the pump to be serviced. Warranty will apply only to the servicing of Spa Baths being carried out by their authorised national service agents.