

ILUMINAR LED Mirrors

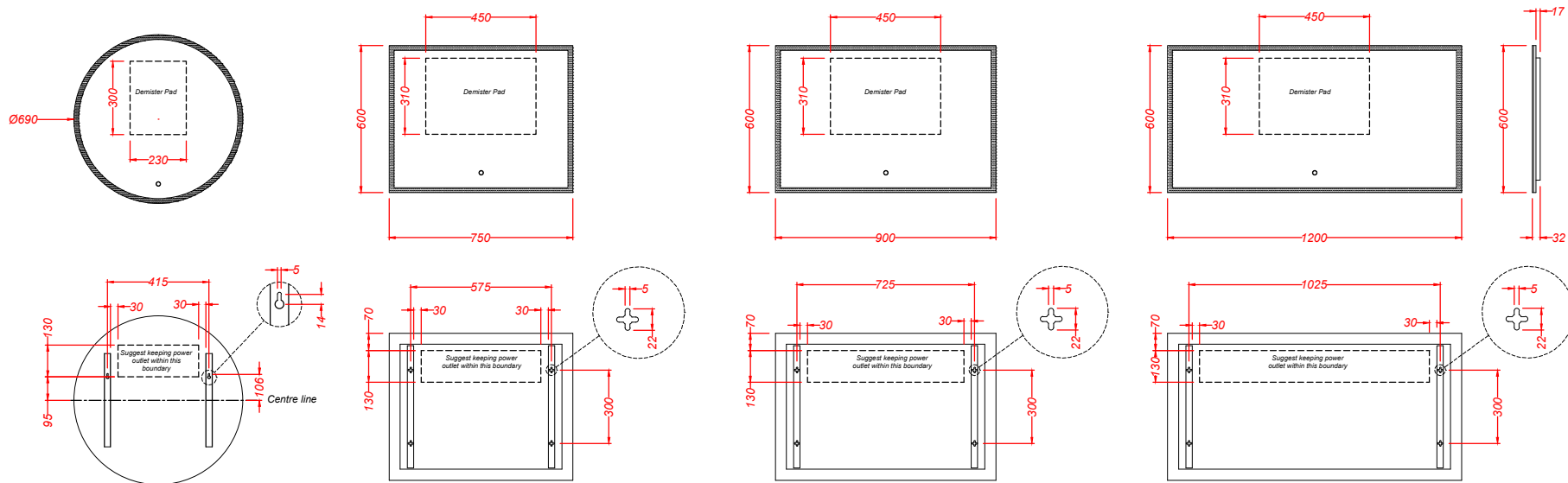
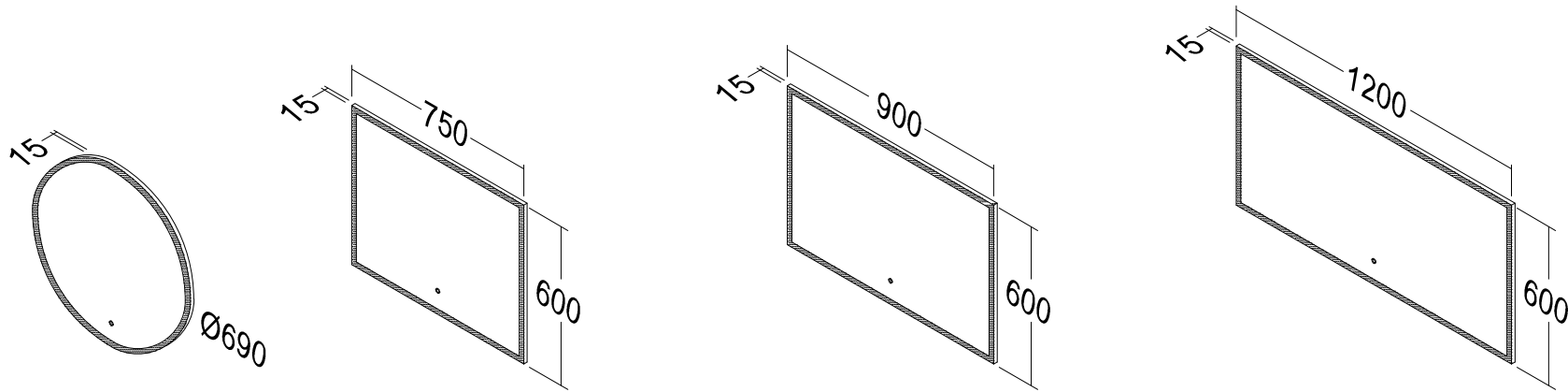

Rear Mounting Details - Use Template provided

ELECTRICAL COMPLIANCE

The NZ Electrical Code of Practice published by Work Safe NZ (NZ Govt) has regulations covering the light fittings that can be installed in bathrooms, these products conform to the IP44 electrical standard requirements. Iluminar LED mirrors also comply with all requirements of AS/NZS CISPR 15:2011 - Radio Frequency emissions, AS/NZS 60598.1:2013 - General Requirements For Luminaries, and AS/NZS 60598.2.1:2014+ A1 - Requirements For Fixed Luminaries.