

Essente

SS2540

Stainless Steel Right Angle Mixer

PREMIUM
304 GRADE
STAINLESS
STEEL

All dimensions in mm

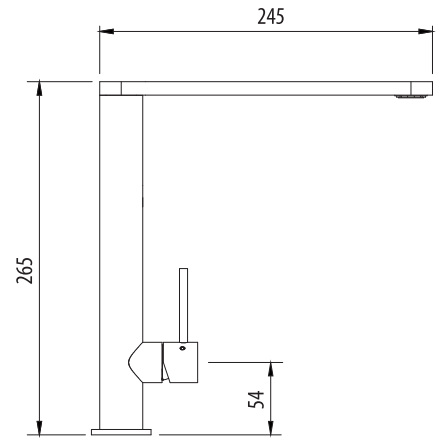

Specifications /

| | |
|--|--|
| WELs rating | 4 Stars, 7.5L per minute |
| Temperature rating (min / max) | 1°C - 65°C |
| Pressure rating (min / max) | 150 kPa - 500 kPa |
| Finish | Natural (stainless steel) |
| Materials | 304 Grade stainless steel body |
| Cartridge size | 25 mm |
| Cartridge type | Ceramic disc cartridge |
| Carton size | 500 x 310 x 75 mm |
| Product weight | 2 kg |
| Mixer height | 265 mm |
| Water supply | Mains |
| Warranty | 10 years (refer to oliveri.co.nz for details) |
| Maintenance and care instructions | All surfaces should be cleaned with mild liquid detergent or soap and water. Do not use cream cleaners or citrus based cleaning products, as they are abrasive. Use of unsuitable cleaning agents may damage the surface. Any damage caused in this way will not be covered by warranty. |