

# HITACHI

ENGLISH

## SPLIT TYPE AIR CONDITIONER

## INDOOR UNIT/OUTDOOR UNIT



### MODEL

RAS-S25YHA/RAC-S25YHA  
RAS-S35YHA/RAC-S35YHA

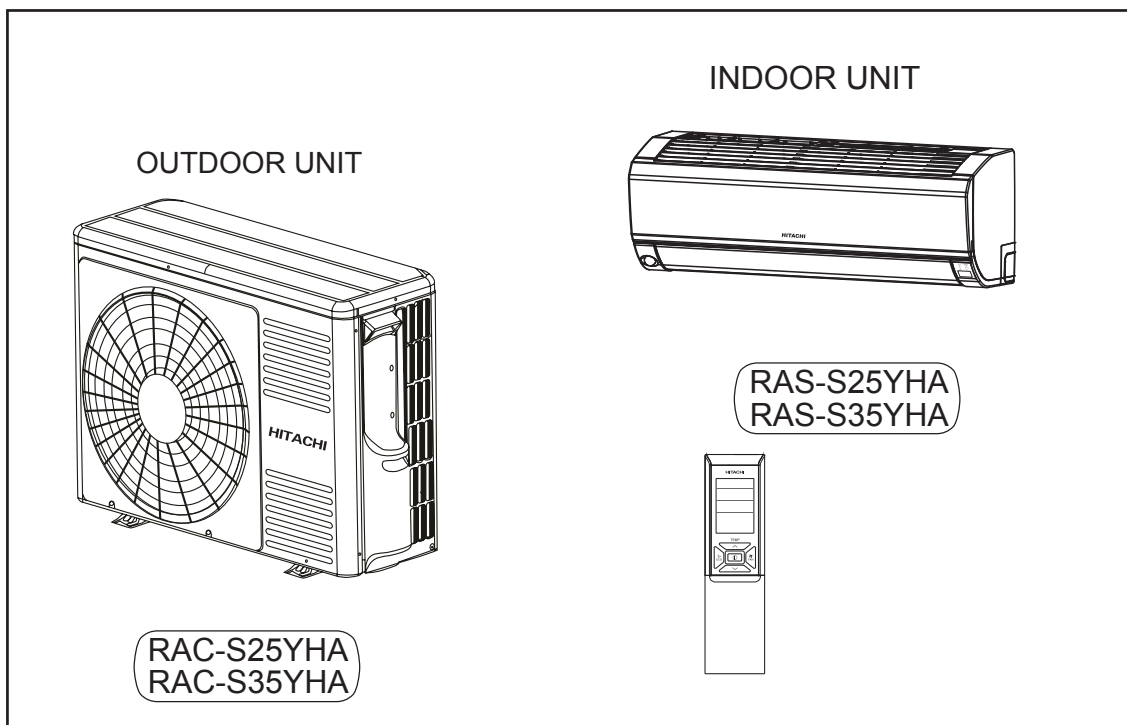

Instruction manual

Page 1~36

To obtain the best performance and ensure years of trouble free use, please read this instruction manual completely.

# SAFETY PRECAUTION



This appliance is filled with R32.

- Please read the “Safety Precaution” carefully before operating the unit to ensure correct usage of the unit.
- Pay special attention to signs of “**▲ Warning**” and “**▲ Caution**”. The “Warning” section contains matters which, if not observed strictly, may cause death or serious injury. The “Caution” section contains matters which may result in serious consequences if not observed properly. Please observe all instructions strictly to ensure safety.
- The signs indicate the following meanings. (The following are examples of signs.)

	Make sure to connect earth line.		This sign in the figure indicates prohibition.
	Indicates the instructions that must be followed.		

- The appliance is not to be used by persons (including children) with reduced physical, sensory or mental capabilities, or lack of experience and knowledge, unless they have been given supervision or instruction.
- Children being supervised not to play with the appliance.
- Please keep this manual after reading.

## PRECAUTIONS DURING INSTALLATION













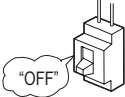







 <b>WARNING</b>	<ul style="list-style-type: none"> <li>• Do not reconstruct the unit. Water leakage, fault, short circuit or fire may occur if you reconstruct the unit by yourself.</li> </ul>	 <small>PROHIBITION</small>
	<ul style="list-style-type: none"> <li>• Please ask your sales agent or qualified technician for the installation of your unit. Water leakage, short circuit or fire may occur if you install the unit by yourself.</li> </ul>	
	<ul style="list-style-type: none"> <li>• Please use earth line. Do not place the earth line near water or gas pipes, lightning-conductor, or the earth line of telephone. Improper installation of earth line may cause electric shock.</li> </ul>	 <small>CONNECT EARTH LINE</small>
	<ul style="list-style-type: none"> <li>• Be sure to use the specified piping set for R32. Otherwise, this may result in broken copper pipes or faults.</li> </ul>	
	<ul style="list-style-type: none"> <li>• If the supply cord is damaged, it must be replaced by a special cord or assembly available from the manufacturer or its service agent.</li> </ul>	
 <b>CAUTION</b>	<ul style="list-style-type: none"> <li>• A circuit breaker should be installed depending on the mounting site of the unit. Without a circuit breaker, the danger of electric shock exists.</li> </ul>	
	<ul style="list-style-type: none"> <li>• Do not install the unit near a location where there is flammable gas. The outdoor unit may catch fire if flammable gas leaks around it. Piping shall be suitable supported with a maximum spacing of 1m between the supports.</li> </ul>	 <small>PROHIBITION</small>
	<ul style="list-style-type: none"> <li>• Please ensure smooth flow of water when installing the drain hose. If any failure is found in the drain path, water drops from the indoor and outdoor units, causing wet household effects.</li> </ul>	
	<ul style="list-style-type: none"> <li>• Make sure that a single phase 220-240V power source is used. The use of other power sources may cause electrical components to overheat and lead to fire.</li> </ul>	 <small>PROHIBITION</small>

## PRECAUTIONS DURING SHIFTING OR MAINTENANCE

 <b>WARNING</b>	<ul style="list-style-type: none"> <li>• Should abnormal situation arise (like burning smell), please stop operating the unit and remove plug from the socket or turn off the circuit breaker. Contact your agent. Fault, short circuit or fire may occur if you continue to operate the unit under abnormal situation.</li> </ul>	 <small>"OFF"</small>
	<ul style="list-style-type: none"> <li>• Please contact your agent for maintenance. Improper self maintenance may cause electric shock and fire.</li> </ul>	
	<ul style="list-style-type: none"> <li>• Please contact your agent if you need to remove and reinstall the unit. Electric shock or fire may occur if you remove and reinstall the unit yourself improperly.</li> </ul>	
	<ul style="list-style-type: none"> <li>• Avoid an extended period of direct air flow for your health.</li> </ul>	 <small>PROHIBITION</small>
	<ul style="list-style-type: none"> <li>• Do not connect the power cable with an extension cable or do not plug too many leads of the other electric appliance into the socket where this cable is plugged. In addition, wire the cable with some allowances to prevent the cable from stretching. Not doing so will cause an electrical shock, heat generation or fire.</li> </ul>	 <small>PROHIBITION</small>
	<ul style="list-style-type: none"> <li>• Do not bundle the power cable, pull it, put something on it, heat it, process it, or put it between things. Breakage of the power cable may result. Use of a damaged cable may cause an electrical shock or a fire.</li> </ul>	 <small>PROHIBITION</small>
	<ul style="list-style-type: none"> <li>• Do not put objects like thin rods into the panel of blower and suction side because the high-speed fan inside may cause danger.</li> </ul>	<small>PROHIBITION</small>



### PRECAUTIONS DURING OPERATION

<b>WARNING</b>	<ul style="list-style-type: none"> <li>Do not use any conductor as fuse wire, this could cause fatal accident.</li> </ul> 
	  <ul style="list-style-type: none"> <li>During thunder storm, disconnect the plug top or turn off the circuit breaker.</li> </ul>
	<ul style="list-style-type: none"> <li>Spray cans and other combustibles should not be located within a meter of the air outlets of both indoor and outdoor units. As a spray can's internal pressure can be increased by hot air, a rupture may result.</li> </ul> 
<b>CAUTION</b>	<ul style="list-style-type: none"> <li>The product shall be operated under the manufacturer specification and not for any other intended use.</li> </ul> 
	 <ul style="list-style-type: none"> <li>Do not attempt to operate the unit with wet hands, this could cause fatal accident.</li> </ul>
	<ul style="list-style-type: none"> <li>When operating the unit with burning equipments, regularly ventilate the room to avoid oxygen insufficiency.</li> </ul>  
	 <ul style="list-style-type: none"> <li>Do not direct the cool air coming out from the air-conditioner panel to face household heating apparatus as this may affect the working of apparatus such as the electric kettle, oven etc.</li> </ul>
	<ul style="list-style-type: none"> <li>Please ensure that outdoor mounting frame is always stable, firm and without defect. If not, the outdoor unit may collapse and cause danger.</li> </ul> 
	 <ul style="list-style-type: none"> <li>Do not wash the unit with water or place a water container such as a vase on the indoor unit. Electrical leakage could be present and cause electric shock.</li> </ul>
	<ul style="list-style-type: none"> <li>Do not place plants or animals directly under the air flow as it is bad for the plants or animals.</li> </ul> 
	 <ul style="list-style-type: none"> <li>Do not climb on the outdoor unit or put objects on it.</li> </ul>
	<ul style="list-style-type: none"> <li>When operating the unit with the door and windows opened, (the room humidity is always above 80%) and with the air deflector facing down or moving automatically for a long period of time, water will condense on the air deflector and drips down occasionally. This will wet your furniture. Therefore, do not operate under such condition for a long time.</li> </ul> 
	 <ul style="list-style-type: none"> <li>If the amount of heat in the room is above the cooling or heating capability of the unit (for example: more people entering the room, using heating equipments and etc.), the preset room temperature cannot be achieved.</li> </ul>
	<ul style="list-style-type: none"> <li>This appliance especially indoor unit cleaning must be performed by authorized personnel only. Consult your sales agent. Using a commercially available detergent or similar can damage the plastic parts or clog the drain pipe, causing water to drip with potential electric shock hazard.</li> </ul> 
	  <ul style="list-style-type: none"> <li>Do not touch the air outlet, bottom surface and aluminum fin of the outdoor unit. You may get hurt.</li> </ul>
	<ul style="list-style-type: none"> <li>Do not touch the refrigerant pipe and connecting valve. Burns may result.</li> </ul>  
	<ul style="list-style-type: none"> <li>This appliance is not intended for use by young children or infirm persons unless they have been adequately supervised by a responsible person to ensure that they can use this appliance safely.</li> <li>Young children should be supervised to ensure that they do not play with the appliance.</li> <li>If the supply cord is damaged, it must be replaced by the manufacturer, its service agent or similarly qualified persons in order to avoid a hazard.</li> </ul>

## NAMES AND FUNCTIONS OF EACH PART

### INDOOR UNIT

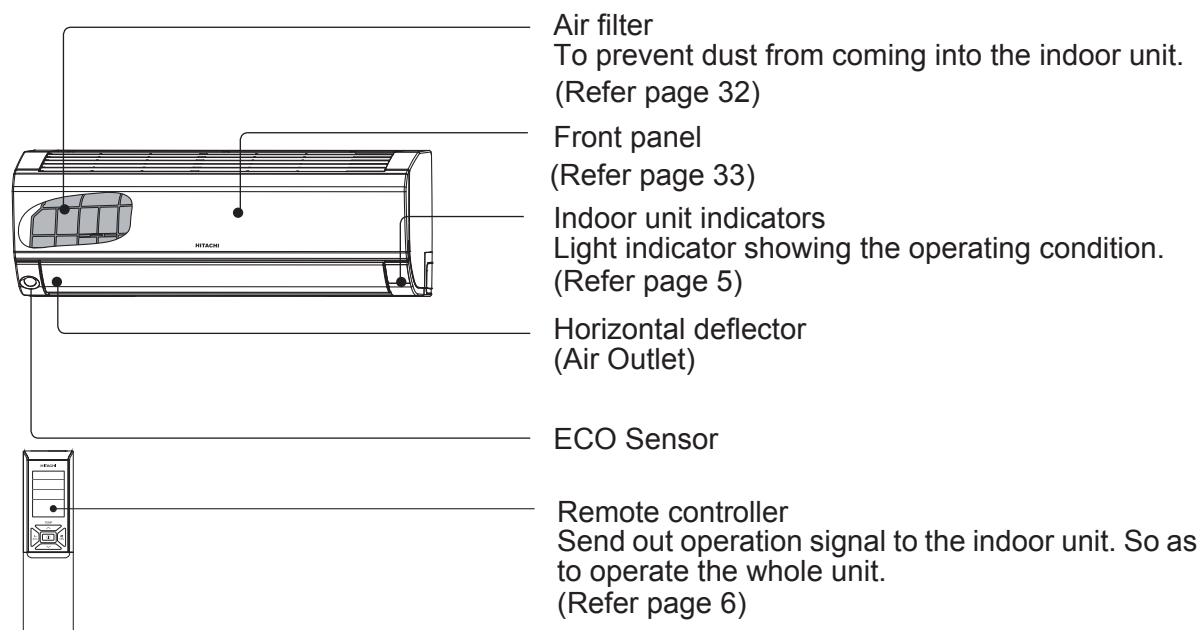

### OUTDOOR UNIT

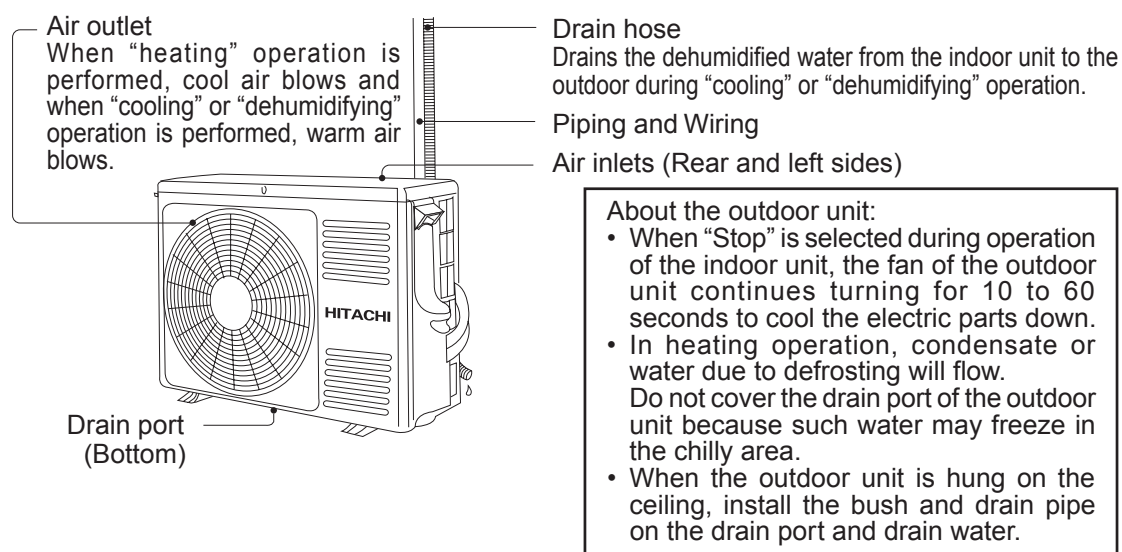

### MODEL NAME AND DIMENSIONS

MODEL	WIDTH (mm)	HEIGHT (mm)	DEPTH (mm)
RAS-S25YHA/RAS-S35YHA	780	280	230
RAC-S25YHA/RAC-S35YHA	792	600	299

# NAMES AND FUNCTIONS OF EACH PART

## INDOOR UNIT INDICATIONS

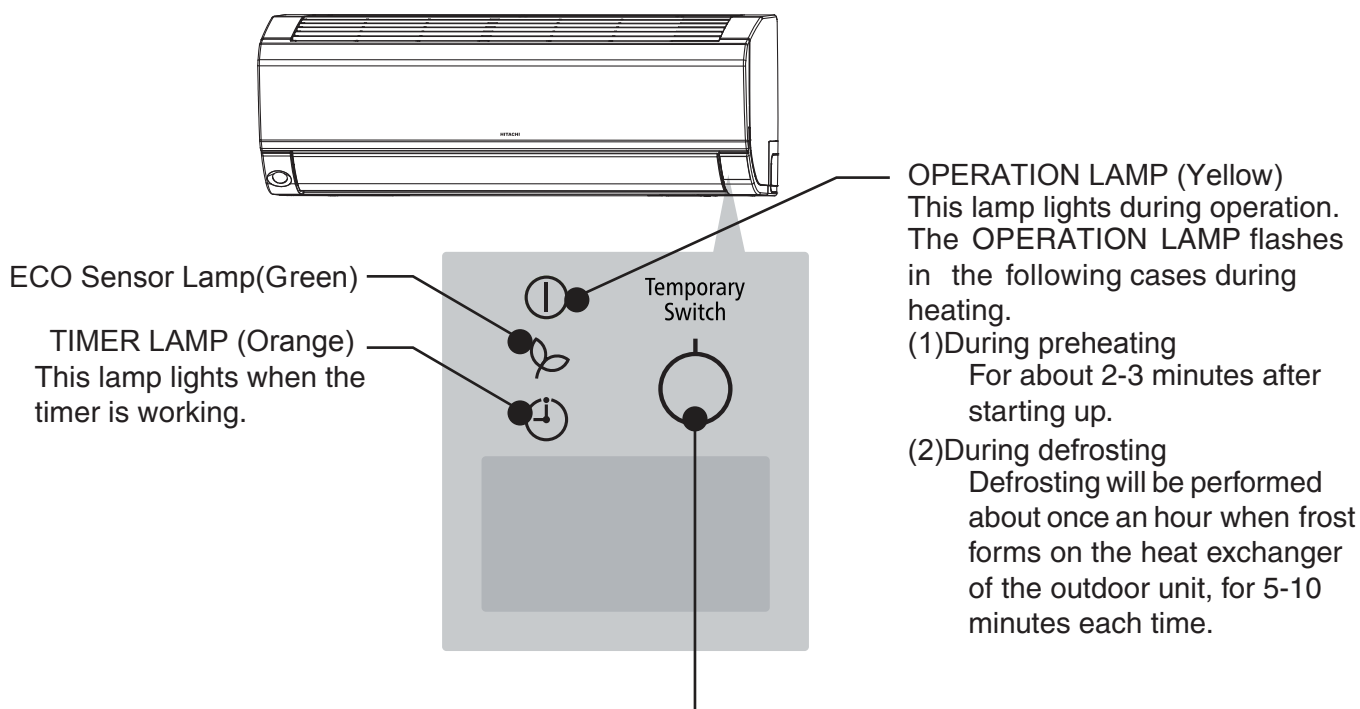

**TEMPORARY SWITCH**  
Use this switch to start and stop when the remote controller does not work.

- By pressing the temporary switch, the operation is done in automatic mode.
- When the operation is done using the temporary switch after the power source is turned off and turn on again, the operation is done in automatic mode.

**CAUTION**  
Turn off the circuit breaker or pull out the power plug if the unit is not be operated for a long period.

☆ If the power stays on and the unit is not operated, power is slightly consumed in the control circuit. The power is saved by turning off the power switch (or the circuit breaker when the power is supplied from the outdoor unit).

- Attaching the Wasabi Air Cleaning Mesh (Accessories) to the filter frame.
  - Attach the Wasabi Air Cleaning Mesh to the C-case by gently compress its both sides and release after insertion into filter frame.
  - The cooling capacity is slightly weakened and the cooling speed becomes slower when the Wasabi Air Cleaning Mesh are used.
  - Wasabi Air Cleaning Mesh are washable and reusable up to 20 times by using vacuum cleaner or water rinse under running tap water. When you want to renew it, please ask your sales agent. Optional air cleansing and deodorizing filters.

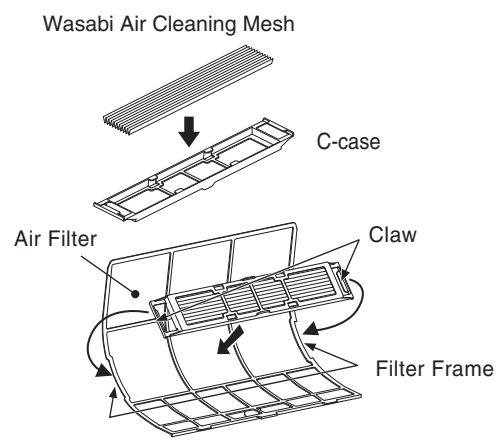

# PREPARATION BEFORE OPERATION

## ■ To install the batteries

1. Slide the cover to take it off.
2. Install two dry batteries AAA.LR03 (alkaline).  
The direction of the batteries should match the marks in the case.
3. Replace the cover at its original position.

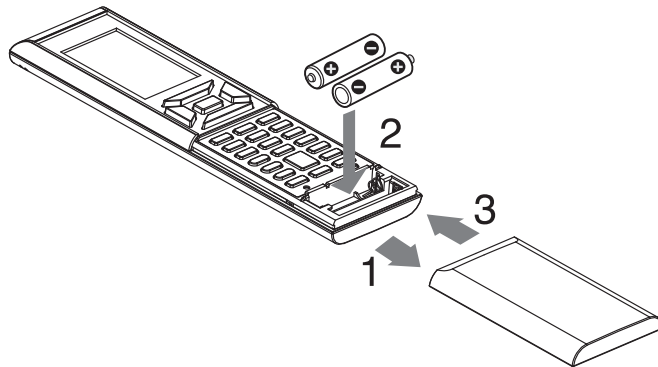

## ■ To fix the remote controller holder to the wall

1. Choose a place from where the signals can reach the unit.
2. Fix the remote controller holder to a wall, a pillar or similar location with the provided screws.
3. Place the remote controller in the remote controller holder.

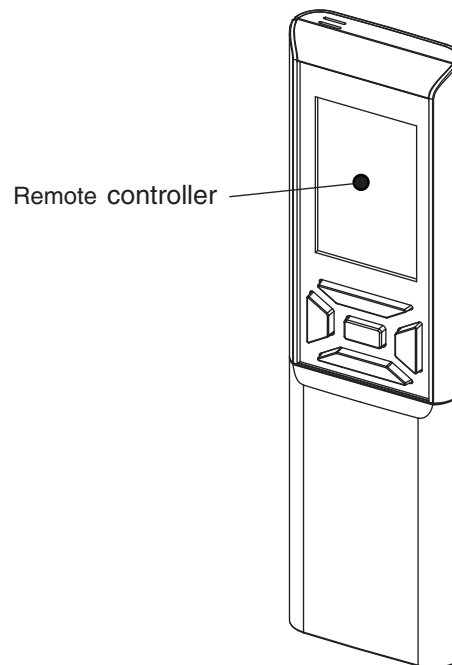

### NOTE

#### Notes on batteries

- When replacing the batteries, use batteries of the same type, and replace both old batteries together.
- When the system is not used for a long time, take the batteries out.
- The batteries will last for approximately 1 year. However, if the remote controller display begins to fade and degradation of reception performance occurs within a year, replace both batteries with new size AAA.LR03 (alkaline).
- The attached batteries are provided for the initial use of the system.  
The usable period of the batteries may be short depending on the manufactured date of the air conditioner.

#### Notes on the remote controller

- Never expose the remote controller to direct sunlight.
- Dust on the signal transmitter or receiver will reduce the sensitivity. Wipe off dust with soft cloth.
- Signal communication may be disabled if an electronic-starter-type fluorescent lamp (such as inverter-type lamps) is in the room. Consult the shop if that is the case.
- If the remote controller signals happen to operate another appliance, move that appliance to somewhere else, or consult the service shop.
- When the remote controller is not in use, please close the slide cover to prevent failure.

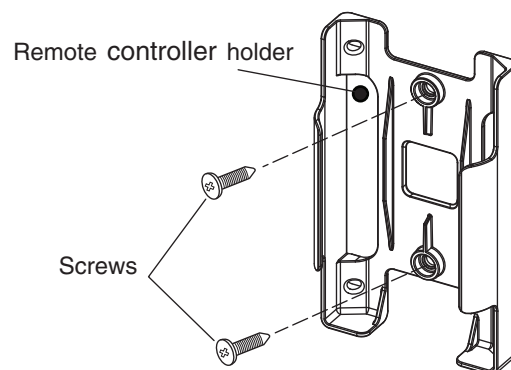

# PREPARATION BEFORE OPERATION

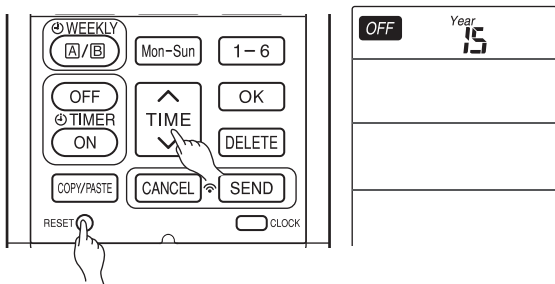

## To set calendar and clock

1. Press **RESET** (RESET) button when first time setting. "Year" blinks.
  2. Press **TIME** (TIME) button to set the current year.
  3. Press **CLOCK** (CLOCK) button. "Day" and "Month" blink.
  4. Press **TIME** (TIME) button to set the current day and month.
  5. Press **CLOCK** (CLOCK) button. "CLOCK" blinks.
  6. Press **TIME** (TIME) button to set the clock to the current time.
  7. Press **CLOCK** (CLOCK) button.
- Calendar and clock are set.

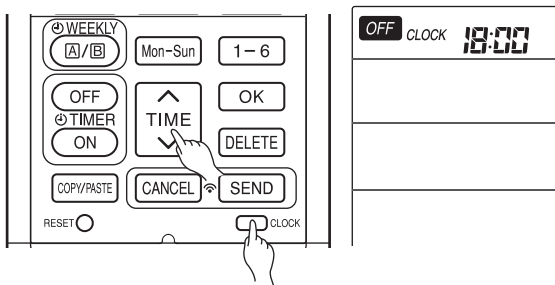
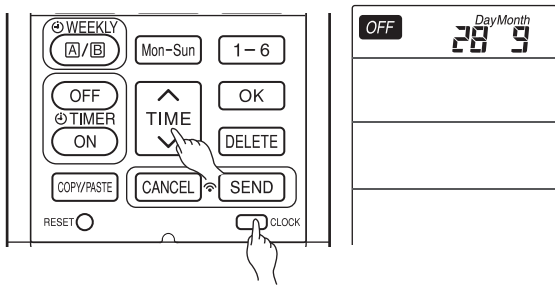

To modify the calendar and clock, press **CLOCK** (CLOCK) button.  
Then follow steps 1 to 7.

Calendar and clock need to be set again after changing batteries.

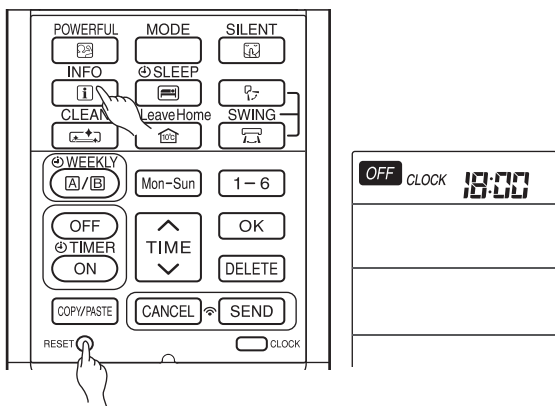

After changing the batteries,

1. Press **RESET** (RESET) button.
2. Direct remote controller towards indoor unit and press **INFO** (INFO) button.
3. The calendar and clock from indoor unit will be transmitted.

Calendar and clock will not be transmitted from indoor unit when the following occurs:

- When there is a power failure.
- When breaker is OFF by user (unit is not in STANDBY MODE).

### NOTE

Note on setting the calendar and clock.

- If the calendar and clock are not set, the ON-timer, OFF-timer and Weekly Timer cannot be set.
- If the calendar and clock are not set correctly, the ON-timer, OFF-timer and Weekly Timer will not operate correctly.
- When the ON-timer, OFF-timer and Weekly Timer are set, the calendar and clock cannot be changed. If there is a need to change the calendar and clock, ON-timer, OFF-timer and Weekly Timer need to be cancelled.

# NAMES AND FUNCTIONS OF REMOTE CONTROLLER

## REMOTE CONTROLLER

- This controls the operation of the indoor unit. The range of control is about 7 meters. If indoor lighting is controlled electronically, the range of control may be shorter.  
This unit can be fixed on a wall using the fixture provided. Before fixing it, make sure the indoor unit can be controlled from the remote controller.
- Handle the remote controller with care. Dropping it or getting it wet may compromise its signal transmission capability.
- After new batteries are inserted into the remote controller, the unit will initially require approximately 10 seconds to respond to commands and operate.
- When remote controller is not in use for about 3 minutes during OFF condition, indicated by **OFF** on the display, the LCD will turn off.
- During clock setting, the LCD will turn off about 10 minutes later if the remote controller is not in use.
- When pressing any button, the LCD will turn on.
- The LCD will not turn off during TIMER setting.

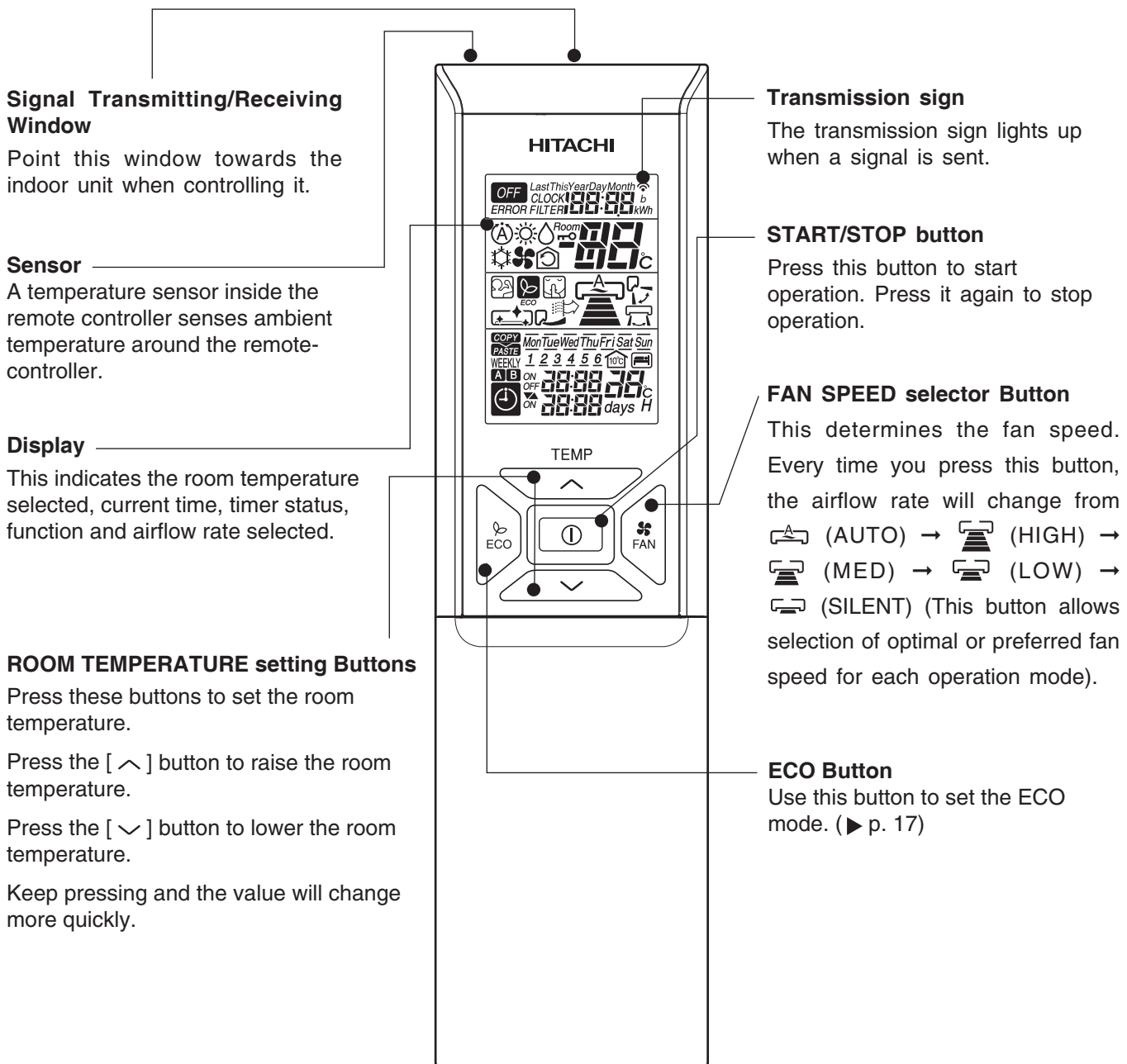



# NAMES AND FUNCTIONS OF REMOTE CONTROLLER

**POWERFUL Button**  
Use this button to set the POWERFUL mode. (▶ p. 15)

**INFORMATION Button**  
(▶ p. 30)

**ONE TOUCH CLEAN Button**  
(▶ p. 20)

**LEAVE HOME Button**  
(▶ p. 19)

**ECO SLEEP TIMER Button**  
Use this button to set the ECO sleep timer. (▶ p. 22)

**ON / OFF TIMER setting Buttons**  
(▶ p. 21)

**MODE selector Button**

Use this button to select the operating mode. Every time you press this button, the mode will change from (A) (AUTO) → (HEAT) → (DEHUMIDIFY) → (COOL) and → (FAN) cyclically.

**SILENT Button**

Use this button to set the SILENT mode. (▶ p. 16)

**AUTO SWING (Vertical) Button**

Controls the angle of the horizontal air deflector. (▶ p. 14)

**AUTO SWING (Horizontal) Button**

Controls the angle of the vertical air deflector. (▶ p. 14)

**WEEKLY TIMER setting Buttons**  
(▶ p. 24)

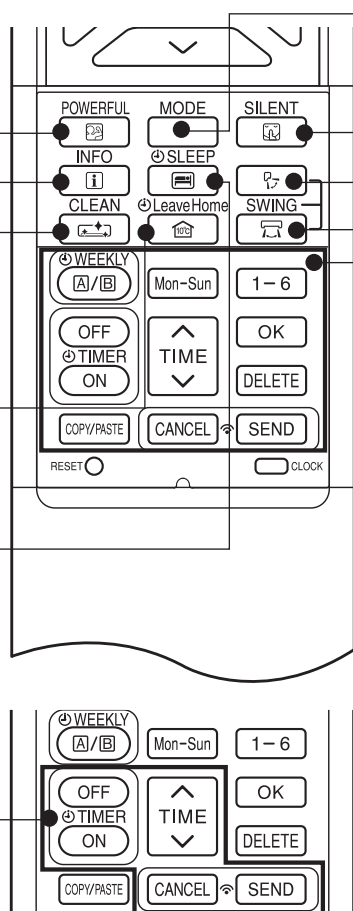

MODE	MODE SELECTOR
(A)	AUTO
(HEAT)	HEAT
(DEHUMIDIFY)	DEHUMIDIFY
(COOL)	COOL
(FAN)	FAN
(A) (FAN SPEED)	FAN SPEED
(A)	AUTO
(SILENT)	SILENT
(LOW)	LOW
(MED)	MED
(HIGH)	HIGH
(i)	START / STOP
(ECO)	ECO

(FAN)	FAN
(POWERFUL)	POWERFUL
(SILENT)	SILENT
(i)	INFO
(SLEEP)	SLEEP TIMER
(AUTO SWING VERT)	AUTO SWING (VERTICAL)
(AUTO SWING HORZ)	AUTO SWING (HORIZONTAL)
(10°C)	LEAVE HOME
(CLEAN)	CLEAN
Mon-Sun	DAY
1-6	PROGRAM NO.

(OFF)	ON / OFF TIMER
(TIMER ON)	ON / OFF TIMER
(TIME)	TIME
(OK)	OK
(DELETE)	DELETE
(COPY/PASTE)	COPY / PASTE
(CANCEL)	CANCEL
(SEND)	SEND
(CLOCK)	CLOCK

**Precautions for Use**

- Do not put the remote controller in the following places.
  - Under direct sunlight.
  - In the vicinity of a heater.
- Handle the remote controller carefully. Do not drop it on the floor, and protect it from water.
- Once the outdoor unit stops, it will not restart for about 3 minutes (unless you turn the power switch off and on or unplug the power cord and plug it in again). This is to protect the device and does not indicate a failure.
- If you press the MODE selector button during operation, the device may stop for about 3 minutes for protection.

# VARIOUS FUNCTIONS

## Auto Restart Control

- If there is a power failure, operation will be automatically restarted when the power is resumed with previous operation mode and airflow direction.  
(As the operation is not stopped by remote controller.)
  - If you intend not to continue the operation when the power is resumed, switch off the power supply. When you switch on the circuit breaker, the operation will be automatically restarted with previous operation mode and airflow direction.
- Note: 1. If you do not require Auto Restart Control, please consult your sales agent.  
2. Auto Restart Control is not available when Timer or Sleep Timer mode is set.

# AUTOMATIC OPERATION

The device will automatically determine the mode of operation, HEAT or COOL depending on the current room temperature. The selected mode of operation will change when the room temperature varies. However, the mode of operation will not change when indoor unit is connected to multi type outdoor unit.

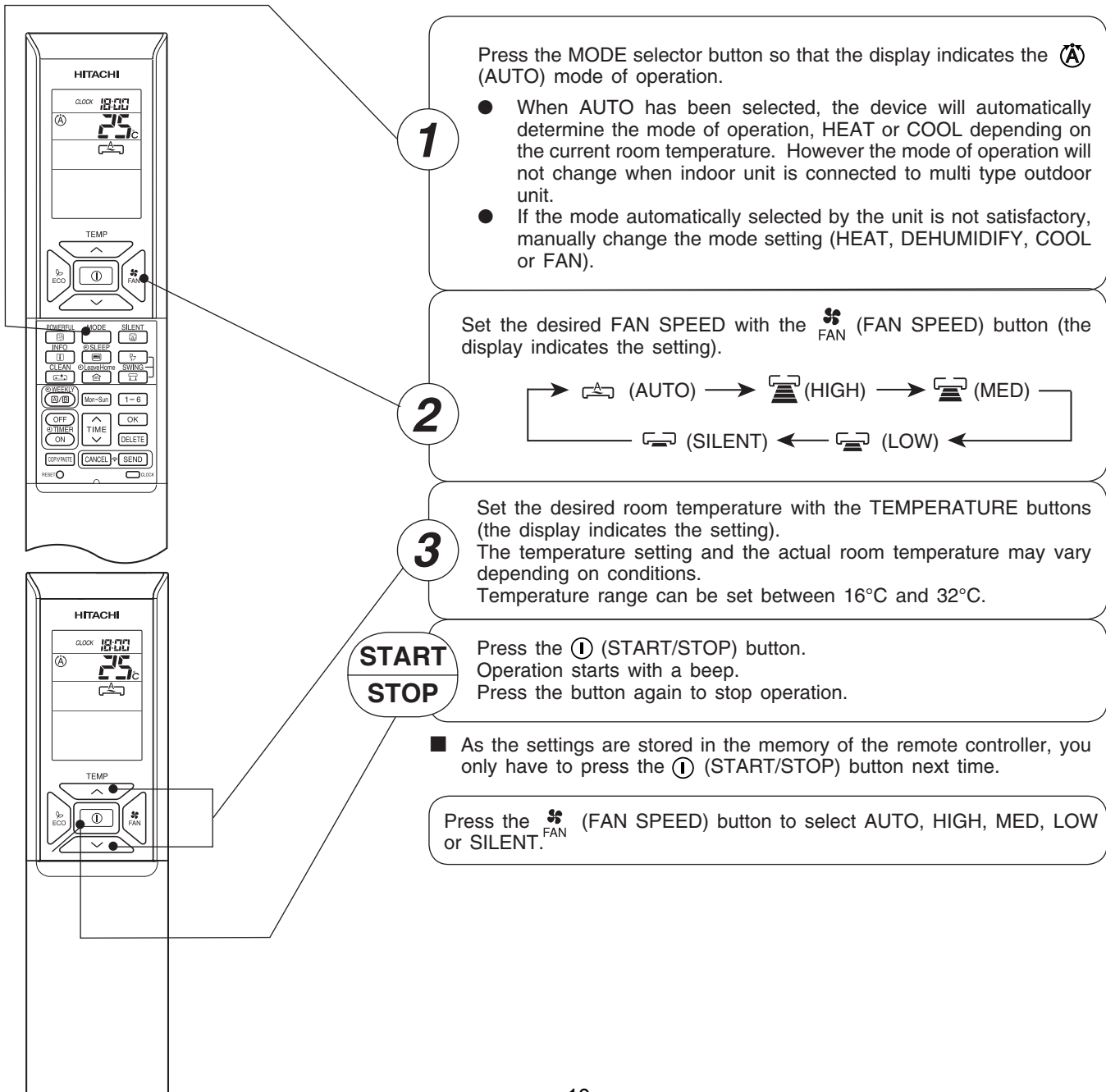

# HEATING OPERATION

- Use the device for heating when the outdoor temperature is under 21°C. When it is too warm (over 21°C), the heating function may not work in order to protect the device.
- In order to maintain reliability of the device, please use this device when outdoor temperature is above -15°C.

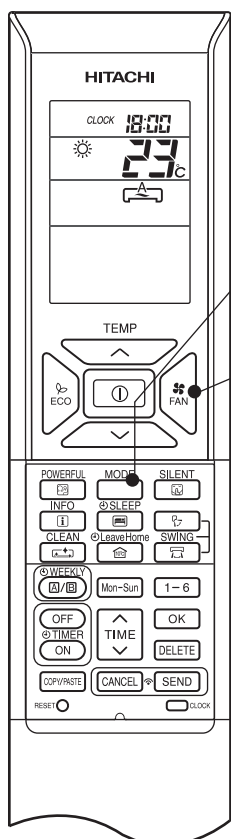

**1** Press the MODE selector button so that the display indicates ☀ (HEAT).

Set the desired FAN SPEED with the (FAN SPEED) button (the display indicates the setting).

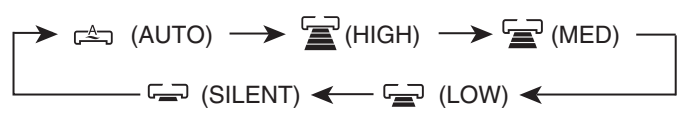

**2** Set the desired room temperature with the TEMPERATURE buttons (the display indicates the setting).  
 The temperature setting and the actual room temperature may vary depending on conditions.  
 Temperature range can be set between 16°C and 32°C.

**START STOP** Press the (START/STOP) button. Heating operation starts with a beep. Press the button again to stop operation.

- As the settings are stored in the memory of the remote controller, you only have to press the (START/STOP) button next time.
- During AUTO fan, the fan speed automatically changes as below:
  - When the difference between room temperature and setting temperature is large, fan starts to run at HI speed.
  - After room temperature reaches the preset temperature, fan speed will be changed to lower speed to obtain optimum room temperature condition for natural healthy heating.

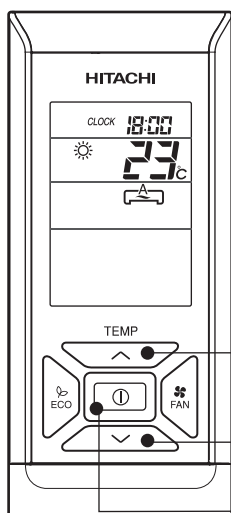

## Defrosting



Defrosting will be performed about once an hour when frost forms on the heat exchange of the outdoor unit, for 5~10 minutes each time.  
 During defrosting operation, the operation lamp blinks in a cycle of 3 seconds on and 0.5 second off.  
 The maximum time for defrosting is 20 minutes.  
 However, if the indoor unit is connected to multi type outdoor unit, the maximum time for defrosting is 15 minutes.  
 (If the piping length used is longer than usual, frost is likely to form.)

# DEHUMIDIFYING OPERATION

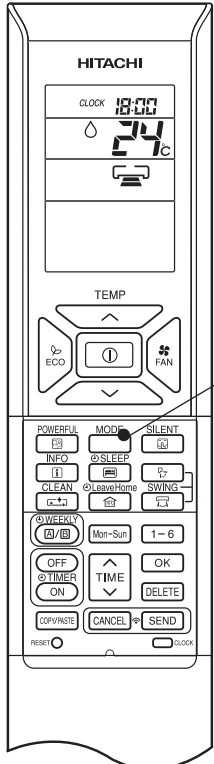
Use the device for dehumidifying when the room temperature is over 16°C.  
When it is under 15°C, the dehumidifying function will not work.



**1**

Press the MODE selector button so that the display indicates  (DEHUMIDIFY).  
The fan speed is set at LOW.  
Press  (FAN SPEED) button to select SILENT or LOW fan speed.

**2**

Set the desired room temperature with the ROOM TEMPERATURE setting buttons (the display indicates the setting).

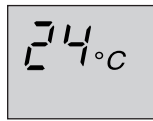

The range of 20-26°C is recommended as the room temperature for dehumidifying.  
Temperature range can be set between 16°C and 32°C.

**START  
STOP**

Press the  (START/STOP) button. Dehumidifying operation starts with a beep. Press the button again to stop operation.

- As the settings are stored in the memory of the remote controller, you only have to press the  (START/STOP) button next time.

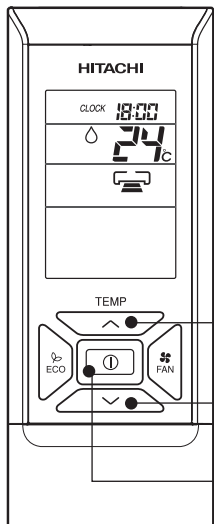



## ■ Dehumidifying Function

- When the room temperature is higher than the temperature setting: The device will dehumidify the room, reducing the room temperature to the preset level.  
When the room temperature is lower than the temperature setting: Dehumidifying will be performed at the temperature setting slightly lower than the current room temperature, regardless of the temperature setting.
- The preset room temperature may not be reached depending on the number of people present in the room or other room conditions.

# COOLING OPERATION

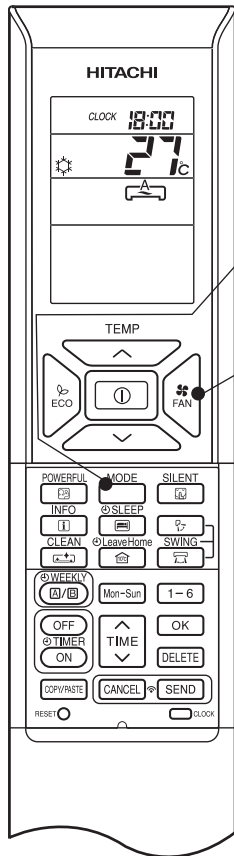
Use the device for cooling when the outdoor temperature is -10~46°C.  
 If indoors humidity is very high (80%), some dew may form on the air outlet grille of the indoor unit.



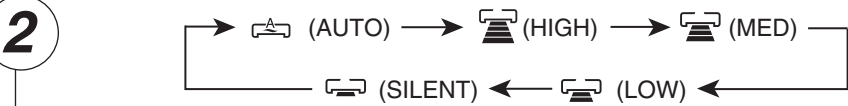

**1** Press the MODE selector button so that the display indicates  (COOL).

Set the desired FAN SPEED with the  (FAN SPEED) button (the display indicates the setting).



**2** Set the desired room temperature with the TEMPERATURE buttons (the display indicates the setting).  
 The temperature setting and the actual room temperature may vary depending on conditions.  
 Temperature range can be set between 16°C and 32°C

**3** Press the  (START/STOP) button. Cooling operation starts with a beep. Press the button again to stop operation. The cooling function does not start if the temperature setting is higher than the current room temperature (even though the  (OPERATION) lamp lights). The cooling function will start as soon as user set the temperature below the current room temperature.

**START STOP**

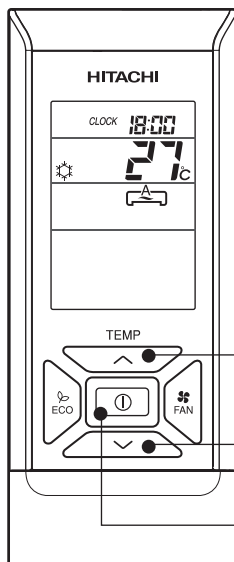

- As the settings are stored in the memory of the remote controller, you only have to press the  (START/STOP) button next time.
- During AUTO fan, the fan speed automatically changes as below:
  - When the difference between room temperature and setting temperature is large, fan starts to run at HI speed.
  - After room temperature reaches the preset temperature, fan speed will be changed to lower speed to obtain optimum room temperature condition for natural healthy cooling.

# FAN OPERATION

User can use the device simply as an air circulator.

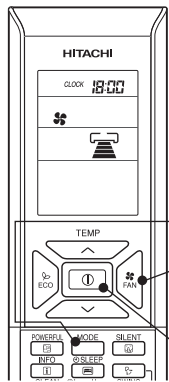

**1**

Press the MODE selector so that the display indicates (FAN).

**2**

Set the desired FAN SPEED with the (FAN SPEED) button (the display indicates the setting).

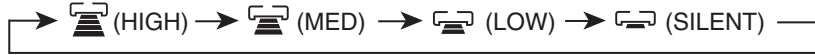

**START STOP**

Press the (START/STOP) button. Fan operation starts with a beep. Press the button again to stop operation.

# AUTO SWING OPERATION

## VERTICAL SWING

### To start Vertical Auto Swing

- Press (AUTO SWING (VERTICAL)) button. The deflector(s) will start to swing up and down.  
 is displayed on the LCD.

### To cancel Vertical Auto Swing

- Press (AUTO SWING (VERTICAL)) button again. The deflector(s) will stop in the current position.  
 disappeared from the LCD.

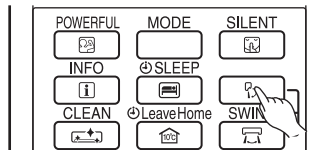

## HORIZONTAL SWING

### To start Horizontal Auto Swing

- Press (AUTO SWING (HORIZONTAL)) button. The deflectors will start to swing right and left.  
 is displayed on the LCD.

### To cancel Horizontal Auto Swing

- Press (AUTO SWING (HORIZONTAL)) button again. The deflectors will stop in the current position.  
 disappeared from the LCD.

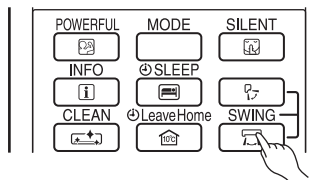

## NOTE

- During cooling and dehumidifying operation, do not keep the deflectors swinging or in the lower position (in the case of vertical auto swing) for a long time. It may cause dew condensation on the deflectors.

## POWERFUL OPERATION

- By pressing  (POWERFUL) button during AUTO, HEATING, DEHUMIDIFYING, COOLING or FAN operation, the air conditioner performs at the maximum power.
- During POWERFUL operation, cooler or warmer air will be blown out from indoor unit for COOLING or HEATING operation respectively.

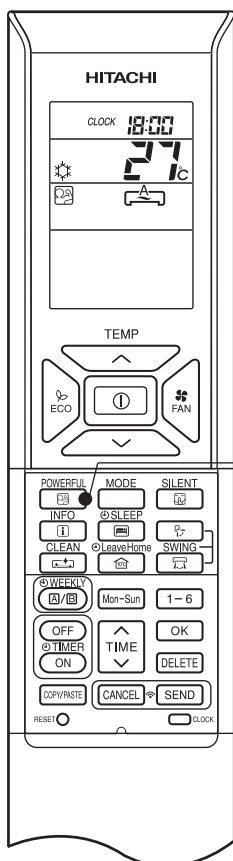



### ■ To start POWERFUL operation

- Press  (POWERFUL) button during operation.

“” is displayed on the LCD.

POWERFUL operation ends in 20 minutes. Then the system automatically operates with the previous settings used before POWERFUL operation.

### ■ To cancel POWERFUL operation

- Press the  (START/STOP) button. Or
- Press  (POWERFUL) button again.

POWERFUL operation stops.

“” disappears from the LCD.

### NOTE

- When SLEEP mode, ECO mode, SILENT mode or LEAVE HOME mode is selected, POWERFUL operation is cancelled.
- During POWERFUL operation, capacity of the air conditioner will not increase
  - if the air conditioner is already running at maximum capacity.
  - just before defrost operation (when the air conditioner is running in HEATING operation).
- After auto restart, POWERFUL operation is cancelled and previous operation shall start.
- For multi model connections, POWERFUL operation may not function depending on operation conditions.

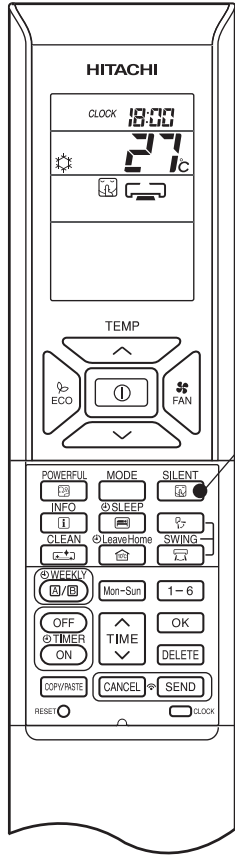

## SILENT OPERATION

- By pressing  (SILENT) button during AUTO, HEATING, DEHUMIDIFYING, COOLING or FAN operation, the fan speed will change to ultra slow.





### ■ To start SILENT operation

1

- Press  (SILENT) button during operation.  
“” is displayed on the LCD. Fan speed will be ultra slow.

### ■ To cancel SILENT operation



- Press  (START/STOP) button. Or
- Press  (SILENT) button again or  (FAN SPEED) button.

Fan speed will return to previous fan speed before SILENT operation starts.

SILENT operation stops.

“” disappears from the LCD.

### NOTE

- When POWERFUL operation is selected, SILENT operation is cancelled. Fan speed will return to previous fan speed before SILENT operation.
- After auto restart, SILENT operation is cancelled. Fan speed will return to previous fan speed before SILENT operation.
- During any operation with fan speed  (SILENT), if press  (SILENT) button, fan speed will not change.





## ECO OPERATION

There are two kinds of ECO OPERATION with sensor or without sensor, depending on models. Please refer to [Names and Functions of each part] in the unit instruction manual to verify if your unit is equipped with a sensor and read the following instruction on ECO Operation accordingly.

### ■ ECO OPERATION

ECO operation is an energy saving function by changing set temperature automatically and by limiting the maximum power consumption value.

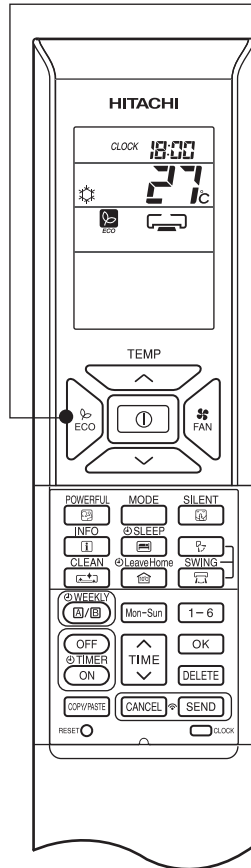

1

- By pressing the  (ECO) button during AUTO, HEATING, DEHUMIDIFYING or COOLING operation, the air conditioner performs the "ECO" operation.

#### ■ To start ECO operation



- Press  (ECO) button during operation.

“” is displayed on the LCD.

A beep sound is emitted from indoor unit.

Energy saving operation will start by changing the set temperature higher or lower automatically and reducing operation power consumption. This function may vary based on the connected outdoor unit.

#### ■ To cancel ECO operation

- Press  (START/STOP) button. Or
- Press  (ECO) button again.

“” disappears from the LCD.

A beep sound is emitted from indoor unit.

#### NOTE

- ECO function will not be effective when power consumption is low.
- By pressing (POWERFUL) button, ECO operation is cancelled.
- After auto restart, ECO operation is cancelled and previous operation mode shall start.
- For multi model connections, energy saving operation shall start only by changing set temperature higher or lower automatically. However, effectiveness of ECO depends on operation conditions.



# ECO OPERATION

## ECO OPERATION with sensor

The sensor detects the presence of people in the room. When nobody is detected, the unit automatically starts energy saving operation by shifting the set temperature in two steps.

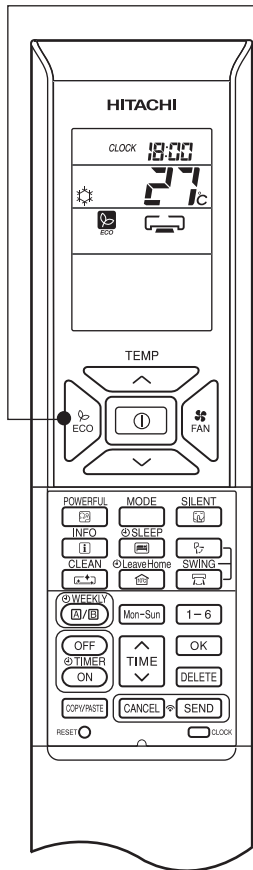

1

- By pressing the (ECO) button during AUTO, HEATING, DEHUMIDIFYING or COOLING operation, the air conditioner performs the "ECO" operation.

### To start ECO operation

- Press (ECO) button during operation.
  - “” is displayed on the LCD.
- A beep sound is emitted from indoor unit and the (ECO) lamp on the indoor unit lights up.
- The sensor starts to detect the presence of people in the room.

### To cancel ECO operation

- Press (START/STOP) button. Or
  - Press (ECO) button again.
  - “” disappears from the LCD.
- A beep sound is emitted from indoor unit and the (ECO) lamp on the indoor unit turns off.

When the presence of people is not detected for 20 minutes, the set temperature is automatically shifted for energy saving. If nobody is in the room for 60 minutes, the set temperature is shifted further.

Cooling operation [diagram representation for illustrative purpose only]

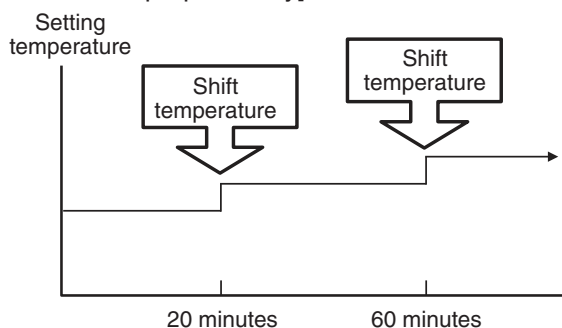

Heating operation [diagram representation for illustrative purpose only]

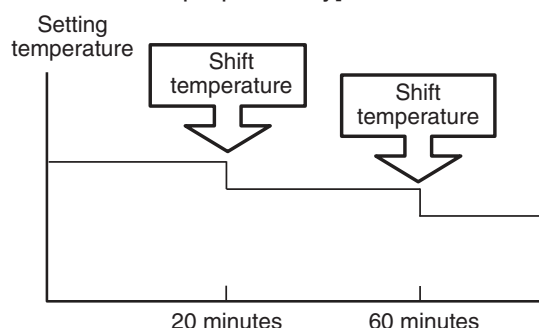

The unit returns to normal operation when the sensor detects human movement.

### NOTE

- By pressing (POWERFUL) button, ECO operation is cancelled.
- After auto restart, ECO operation is cancelled and previous operation mode shall start.

# 10°C LEAVE HOME (LH) OPERATION

Prevent the room temperature from falling too much when no one is at home. The initial setting temperature is 10°C and the temperature range can be set between 10°C and 16°C.

This operation is able to operate by "Continuous operation" or "Day timer operation". Please use "Day timer operation" to set the number of days up to 99 days.

## Continuous operation

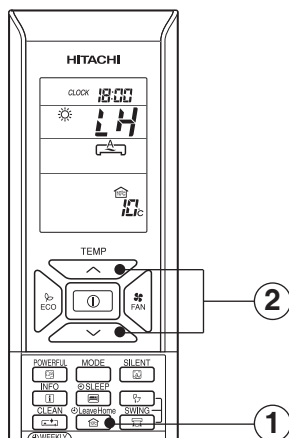

## Day timer operation

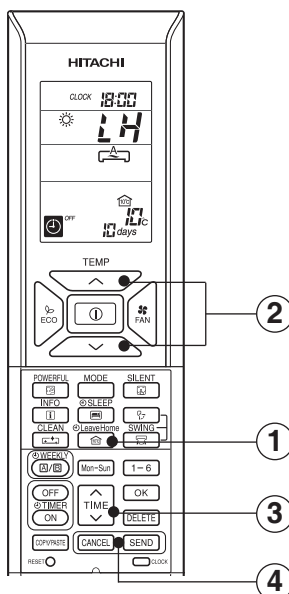

## To start LEAVE HOME operation

### Option 1. Continuous operation.

- Press (LEAVE HOME) button during stop or operation. Room temperature is set at 10°C and heating operation starts.
- Set the desired room temperature with the TEMPERATURE buttons. Temperature range can be set between 10°C and 16°C.  
 "☀", "LH", "A", "10°C", "SET TEMPERATURE" is displayed on the LCD.

### Option 2. Day timer operation.

- Press (LEAVE HOME) button during stop or operation. Room temperature is set at 10°C and heating operation starts.
- Set the desired room temperature with the TEMPERATURE buttons. Temperature range can be set between 10°C and 16°C.  
 "☀", "LH", "A", "10°C", "SET TEMPERATURE" is displayed on the LCD.

- Set number of operation days (1 to 99 days), if needed.  
 Press (TIME) button to select number of days.  
 Number of days blink.  
 \* Press "∧ (UP)" or "∨ (DOWN)" to set number of days from 1 day to 99 days.  
 \* Number of day is counted when clock indicates 0:00.
- Press (SEND) button to confirm number of operation days. Display for number of operation days will stop blinking.  
 Press (CANCEL) button to reset number of operation days or to have continuous operation.

## To cancel LEAVE HOME operation

- Press (START/STOP) button. Or
- Press (LEAVE HOME) button again. Return to previous operation mode. Or
- Change to other operation mode by pressing (MODE) button.

## NOTE

- After reaching the set number of operation days for Leave Home or by pressing the (Leave Home) button again, the unit will operate in previous mode.
- During Leave Home operation, fan speed and horizontal air deflector position cannot be changed.
- By pressing (Leave Home) button, implementation of Weekly Timer or Once Timer is cancelled.
- In case of power supply shut down, after autorestart, all setting for number of days operation will be reset and unit shall be in continuous operation.
- POWERFUL, SILENT and ECO operations are not applicable during Leave Home operation.
- For multi connection
  - FAN/COOLING/DEHUMIDIFYING and Leave Home cannot operate at the same time. The first-run unit has a priority and other units in different mode will be in standby mode.
  - Heating operation can be used with Leave Home.
  - When two or more rooms are set to operate Leave Home, the temperature set by Leave Home may not be reached. It also depends on outdoor temperature.

## CLEAN (ONE TOUCH CLEAN) OPERATION

Drying indoor heat exchanger after cooling operation to prevent mildew.

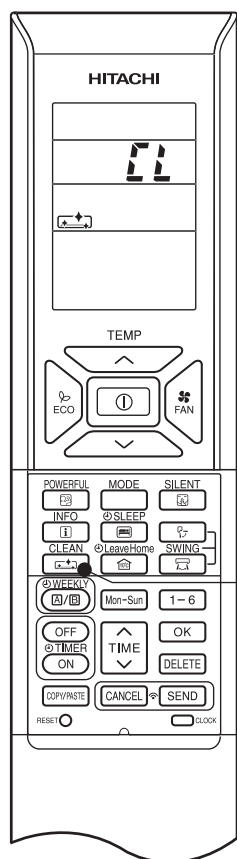



### ■ To start CLEAN operation

- Press  (CLEAN) button when unit is OFF.  
Total time taken for One Touch Clean operation is 60 minutes. During this operation, HEATING or FAN operation shall operate.  
During one touch clean, operation lamp is blinking.

“”, “” is displayed on the LCD.

### ■ To cancel CLEAN operation

- Press  (START/STOP) button. Or
- Press  (CLEAN) button again.

### NOTE

- When CLEAN operation finish, unit will switch OFF automatically.
- If Weekly Timer or Once Timer is set, there is a need to cancel those timer before operating CLEAN function.
- For multi connections, when pressing  (CLEAN) button, operation is limited to FAN operation.
- For multi connections, when one room operates CLEAN operation first, other rooms can operate COOLING, DEHUMIDIFYING or FAN operation. However, when other rooms need to operate HEATING operation, air conditioner will be in STANDBY mode. After CLEAN operation finish, HEATING operation will start.



# ONCE TIMER (ON/OFF TIMER) OPERATION

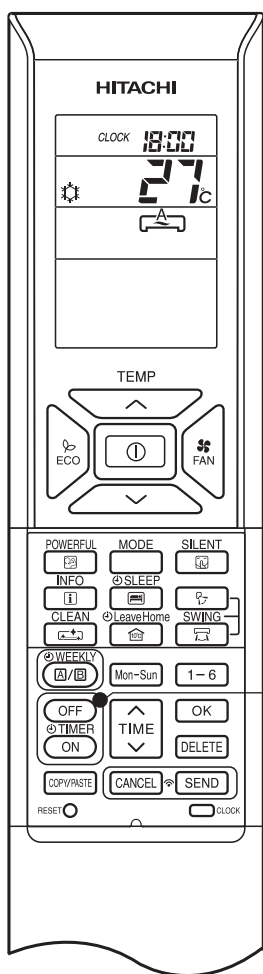

## OFF TIMER

The device can be set to turn off at a preset time.

1. Press (OFF-TIMER) button. and **0:00** blink on the display.
2. Set the "turn-off time" with (TIME) button.
3. After setting, direct the remote controller towards the indoor and press (SEND) button.

and "set time" lights up instead of blinking.

A beep sound emitted from indoor unit and the (TIMER) lamp on the indoor unit lights up.

## ON TIMER

The device will turn on at a designated time.

1. Press (ON-TIMER) button. and **6:00** blink on the display.
2. Set the "turn-on time" with (TIME) button.
3. After setting, direct the remote controller towards the indoor and press (SEND) button.

and "set time" light up instead of blinking.

A beep sound emitted from indoor unit and the (TIMER) lamp on the indoor unit lights up.

## ON/OFF TIMER

- The device will turn on (off) and off (on) at the designated time.
- The switching occurs first at the preset time that comes earlier.
- The arrow mark appears on the display to indicate the sequence of switching operations.

1. Press (OFF-TIMER) button so that and **0:00** blink on the display.
2. Set the "turn-off" time with (TIME) button. After setting, direct the remote controller towards the indoor and press (SEND) button.
3. Press (ON-TIMER) button so that and set "turn-off" time light up. The and **6:00** blink.
4. Set the "turn-on" time with (TIME) button.
5. After setting, direct the remote controller towards the indoor and press (SEND) button

and set "turn-on" time light up instead of blinking.

A beep sound emitted from indoor unit and the (TIMER) lamp on the indoor unit lights up.

■ The timer may be used in three ways: OFF-timer, ON-timer and ON/OFF (OFF/ON)-timer. Set the current time first because it serves as a reference.

## ■ To cancel Reservation

- Point the signal window of the remote controller towards the indoor unit and press (CANCEL) button. and "ON or OFF set time" goes out with a beep and the (TIMER) lamp on the indoor unit turns off.

## NOTE

- User can set only one of the OFF-timer, ON-timer or ON/OFF-timer.
- If WEEKLY TIMER already set, by setting the ONCE TIMER, ONCE TIMER operation is prioritized. When ONCE TIMER operation is complete, WEEKLY TIMER operation will be activated.



## ECO SLEEP TIMER OPERATION

The timer can be set up to a duration of 7 hours.

By pressing (SLEEP) button during AUTO, HEATING, DEHUMIDIFYING, COOLING or FAN operation, the unit shifts the room temperature and reduces the fan speed. It results in energy saving.

Set the current time first before operating the ECO SLEEP TIMER operation.

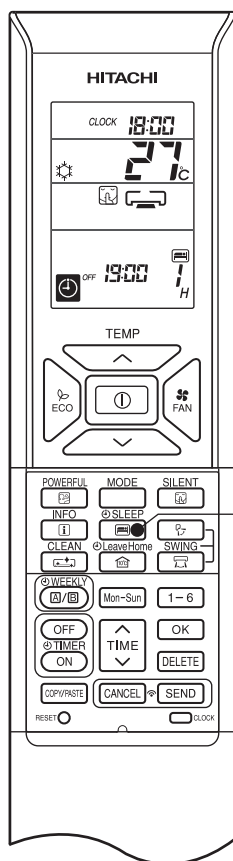

### To start ECO SLEEP TIMER operation

Press (SLEEP) button during operation.

- “”, “”, “”, “OFF”, off time, “” and number of hour are displayed on the remote controller display.
- During ECO SLEEP TIMER operation, fan speed will be ultra slow.
- A beep sound emitted from indoor unit and the (TIMER) lamp on the indoor unit lights up.

Pressing (SLEEP) button repeatedly, the number of hours will change as below:



- During ECO SLEEP TIMER operation, air conditioner will continue to operate for the designated number of hours and then turn off.
- When the ECO SLEEP TIMER has been set, the display on the remote controller indicates the turn off time.



Example: If ECO SLEEP TIMER is set for 1 hour at 18:00, the switch off time will be at 19:00.

### To cancel ECO SLEEP TIMER operation

Press (START/STOP) button.

- Room air conditioner will switch off.

Press (SLEEP) button again until “”, “”, “”, off time, “” and number of hour disappear from the remote controller display.

Press (CANCEL) button.

- A beep sound emitted from indoor unit and the (TIMER) lamp on the indoor unit turns off.
- SLEEP TIMER operation is cancelled.



## ECO SLEEP TIMER OPERATION

### ■ To set ECO SLEEP TIMER and ON TIMER

The air conditioner will be turned off by ECO SLEEP TIMER and turned on by ON TIMER.

1. Set the ON TIMER.
2. Press (SLEEP) button and set ECO SLEEP TIMER.



Example:  
In this case, air conditioner will turn off in 2 hours (at 1:38) and it will be turned on at 6:00 the next morning.

### ■ To cancel ECO SLEEP TIMER and ON TIMER operation

Direct the remote controller towards the indoor unit and press (CANCEL) button.

- “”, “”, “”, “OFF”, off time, “”, number of hour, “ON” and ON TIMER set time disappear from the remote controller display.
- A beep sound emitted from indoor unit and the (TIMER) lamp on the indoor unit turns off.
- ECO SLEEP TIMER and ON TIMER reservations are cancelled.

30 minutes after setting ECO SLEEP TIMER, outdoor fan speed will be reduced to lower the noise level and to have comfort operation.

1 hour after setting ECO SLEEP TIMER, set temperature will be slightly shifted. Amount of temperature shifted depends on type of air conditioner.

These automatic operation changes contribute to energy saving without losing comfort.

The level of energy consumption depends on outside temperature, room temperature, set temperature or air conditioner type.

Cooling operation [diagram representation for illustrative purpose only]

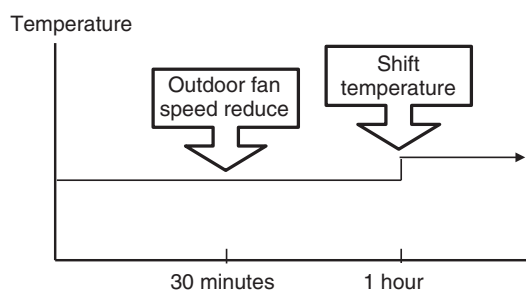

Heating operation [diagram representation for illustrative purpose only]

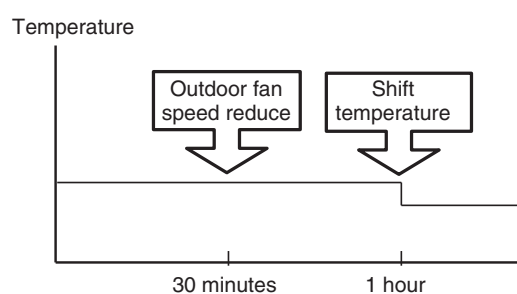

#### NOTE

- If ECO SLEEP TIMER is set when OFF TIMER or ON/OFF TIMER has been set earlier, the ECO SLEEP TIMER becomes effective instead of the OFF TIMER or ON/OFF TIMER.



## WEEKLY TIMER OPERATION

- It is possible to select Mode A or Mode B. For each mode, up to 6 programs can be set per day. In total, a maximum of 42 programs can be set for a week for each mode.
- If calendar and clock are not set, the reservation setting for WEEKLY TIMER cannot be set.
- If calendar and clock are not set correctly, WEEKLY TIMER will not operate correctly.
- Reservation for calendar and clock shall be set first before operating WEEKLY TIMER.

**Step 1: Set the reservation schedule to the remote controller. Send the registered reservation to indoor unit and then operate.**

**Step 2: Select Mode A or Mode B and activate or deactivate WEEKLY TIMER .**

**Step 3: Copy and cancel the reservation schedule.**

**Step 1 : Set reservation schedule to the remote controller. Send the registered reservation to indoor unit and then operate.**

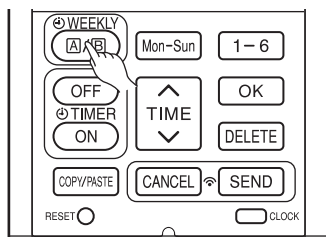

1

### ■ How to set a WEEKLY TIMER.

#### 1. Select Mode A or Mode B

Press (WEEKLY) button. WEEKLY lights up. **A** and blink on the display. (Mode A is selected).

Press (WEEKLY) button again, **B** and blink on the display. (Mode B is selected).

- If no reservation has been made, ON/OFF, --:-- , appear.
- If reservation has been made, ON/OFF, --:-- , will not appear.

2

#### 2. Set a program

Press (WEEKLY) button for about 3 seconds. The selection mode can be changed.

, day: Mon, program no. : 1, ON/OFF, setting time and setting temperature blink on the display.

#### 3. Select the desired day of the week

Press (DAY) button.

The day changes from Mon → Tue → Wed → Thu → Fri → Sat → Sun → Mon, Tue, Wed, Thu, Fri, Sat, Sun [Full days] → Mon, Tue, Wed, Thu, Fri [weekday] → Sat, Sun [weekend] → Mon → Tue .....

Select [Full days] for daily reservation.

Select [weekday] for Monday to Friday reservation.

Select [weekend] for Saturday and Sunday reservation.

- After reservation has been set, it is easy to check and edit at the same time.

3

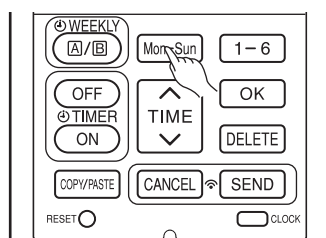

#### 4. Press button to select a program number.

The number changes from 1 → 2 → 3 → 4 → 5 → 6 → 1 → 2 .....

- If program number has been set, follow above in order to make changes.

4

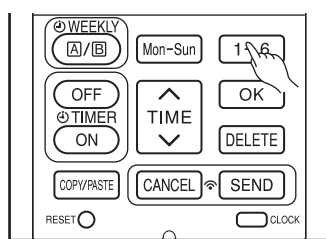



## WEEKLY TIMER OPERATION

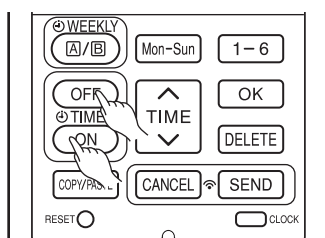

5

5. Press (ON-OFF TIMER) button to select ON TIMER or OFF TIMER reservation.

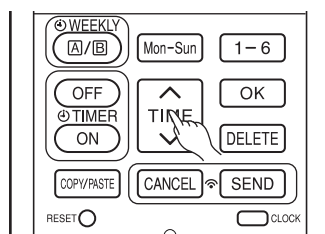

6

6. Press (TIME) button to set time reservation.

7. Press (TEMP ^ or v) button to set temperature reservation.

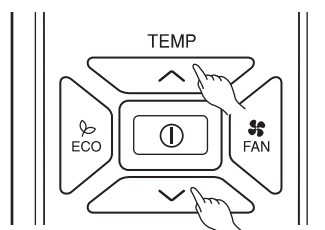

7

8. Press (OK) button. The reservations are set. Day, program number, ON reservation, setting temperature will light up. will be continuously blinks. If reservation is not complete, settings will not be stored in memory.

To continue with the reservation, press buttons. Follow step 3 to 8 for reservation.

9. After all the reservations have been set, press (SEND) button while directing the remote controller towards the indoor unit for about 3 seconds. Timer lamp on the indoor unit will blink rapidly.

After beep sound emitted from indoor unit, TIMER lamp will light up.

**Please ensure that the TIMER lamp lights up.**

This indicates that the reservation has been stored in the indoor unit and Timer function has been completed.

The reservation contents will appear on the remote controller display.

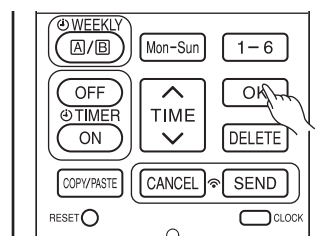

8

- If TIMER lamp on the indoor unit does not light up, press (SEND) button while directing the remote controller towards the indoor unit for about 3 seconds.

- **CAUTION !** Do not press (CANCEL) button during reservation setting because this will result in all reservation contents to be lost.

- The reservation contents will not stored in the indoor unit until (SEND) button has been pressed.

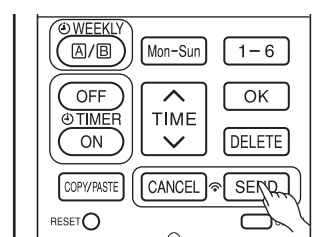

9

### NOTE

- Up to 6 programs can be set per day. Setting ON TIMER or OFF TIMER for each program number can be at random. When pressing (SEND) button, the set ON TIMER or OFF TIMER for each program number will automatically arranged so that program number 1 shall have the earliest time and program number 6 shall have the latest time.  
If the setting time is the same, Priority will be given to the latest reservation contents.
- **CAUTION !** If the remote controller is left idle and (SEND) button is not pressed within 3 minutes after reservations have been made , all current reservations will be lost.



## WEEKLY TIMER OPERATION

### Step 2: Select Mode A or Mode B and activate or deactivate WEEKLY TIMER.

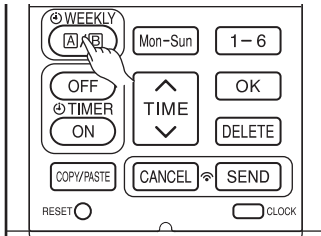

1  
2

#### ■ How to select Mode A or Mode B of WEEKLY TIMER setting.

1. Press **WEEKLY (A/B)** (WEEKLY) button. **A** and **⏸** blink on the display. (Normally Mode A will blink first).
2. Press **WEEKLY (A/B)** (WEEKLY) button again. **B** and **⏸** blink on the display.
3. Select Mode A or Mode B. Press **SEND** (SEND) button while directing the remote controller towards the indoor unit for about 3 seconds. Timer lamp on the indoor unit will blink rapidly.

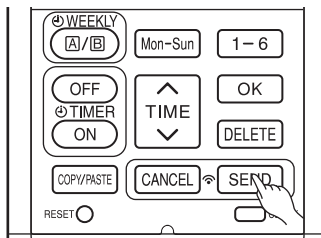

3

After beep sound emitted from indoor unit, TIMER lamp will light up.

**Please ensure that the TIMER lamp lights up.**

This indicates that Mode A or Mode B selection and active WEEKLY TIMER have been confirmed.

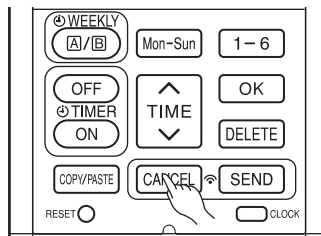

1

#### ■ Setting non-active WEEKLY TIMER .

1. Direct the remote controller towards the indoor unit and press **CANCEL** (CANCEL) button. Beep sound will be emitted from indoor unit and TIMER lamp will be OFF. Reservation indication on remote display will also disappear. This indicates that non-active WEEKLY TIMER has been confirmed.
- To activate back the setting of WEEKLY TIMER , repeat the steps for "How to select Mode A or Mode B of WEEKLY TIMER setting".

#### NOTE

- When setting ONCE TIMER, operation of WEEKLY TIMER is interrupted. After ONCE TIMER operation is complete, WEEKLY TIMER operation will be activated.
- When ONCE TIMER is cancelled, operation of WEEKLY TIMER is also cancelled. Need to set WEEKLY TIMER operation for activation.
- After auto restart, WEEKLY TIMER operation is cancelled. Need to set WEEKLY TIMER operation for activation.

# WEEKLY TIMER OPERATION

## Step 3: Copy and cancel the reservation schedule.

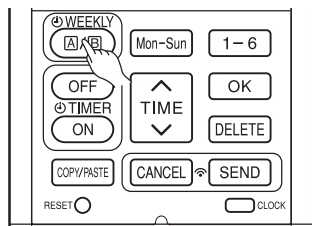

1

### How to copy and paste.

Editing the reservation schedule is easy by copying data from one day to another day.

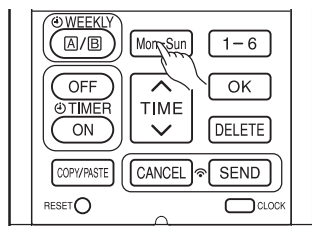

2

1. Press **WEEKLY** (WEEKLY) button to select Mode A or Mode B.

2. Press **WEEKLY** (WEEKLY) button for about 3 seconds to start editing the reservation schedule.

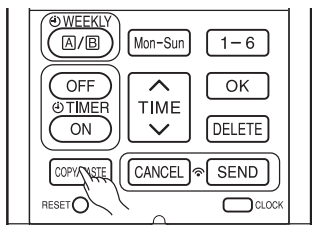

3

3. Press **Mon-Sun** (DAY) button to select a day of the week to copy.

4. Press **COPY/PASTE** (COPY/PASTE) button. Then "PASTE" blinks on the display.

\* Press **CANCEL** (CANCEL) button to cancel the COPY mode. Normal setting mode is activated.

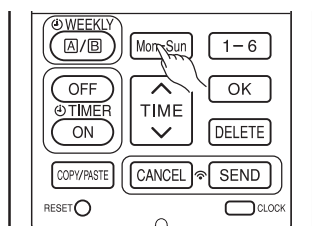

4

5. Press **Mon-Sun** (DAY) button to select a day of the week to paste.

6. Press **COPY/PASTE** (COPY/PASTE) button one more time to paste. **⏻** only blinks on the display.

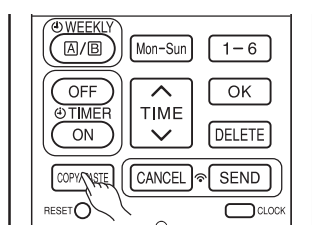

5

7. To continue copying to other days, press **Mon-Sun** or **1-6** or **TIME** or



Then start from step 3.

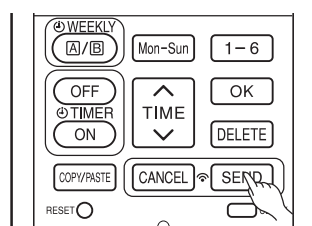

6

8. After copy and paste completed, press **SEND** (SEND) button while directing the remote controller towards the indoor unit for about 3 seconds. Timer lamp on the indoor unit will blink rapidly.

After beep sound emitted from indoor unit, **TIMER** lamp will light up.

**Please ensure that the TIMER lamp lights up.**

If **TIMER** lamp does not light up, Press **SEND** (SEND) button again.

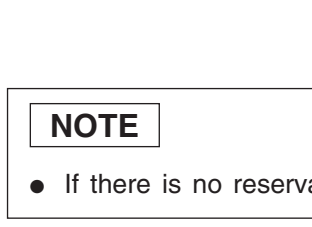

8

● Reservation data will not change if **SEND** (SEND) button is not pressed.

### NOTE

- If there is no reservation data, copying data from one day to another day cannot be done.



# WEEKLY TIMER OPERATION

## Step 3: Copy and cancel the reservation schedule.

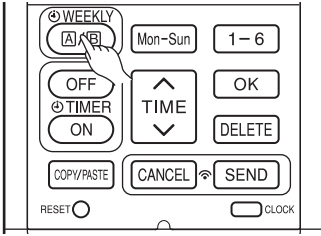

1

### How to delete WEEKLY TIMER data.

[Delete one program number reservation]

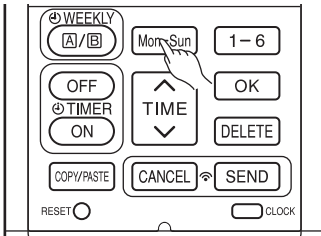

2

1. Press **WEEKLY (A/B)** (WEEKLY) button to select Mode A or Mode B.

2. Press **WEEKLY (A/B)** (WEEKLY) button for 3 seconds to start editing the reservation schedule.

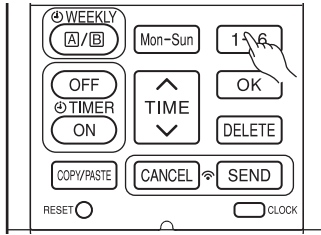

3

3. Press **Mon-Sun** (DAY) button to select a day of the week to edit.

4. Press **1-6** to select program number. Selected program number will blink.

5. Press **DELETE** (DELETE) button. Reservation of selected program number is deleted.

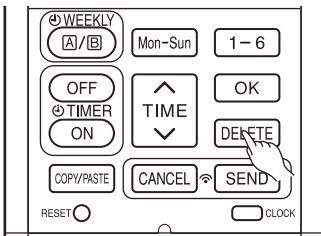

4

6. After deleting, press **SEND** (SEND) button while directing the remote controller towards the indoor unit for about 3 seconds. Timer lamp on the indoor unit will blink rapidly.

After beep sound emitted from indoor unit, TIMER lamp will light up.

**Please ensure that the TIMER lamp lights up.**

● Reservation will not change if **SEND** (SEND) button is not pressed.

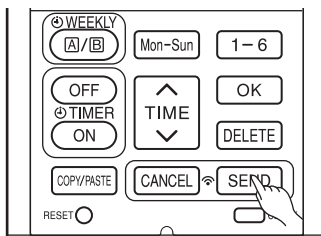

5

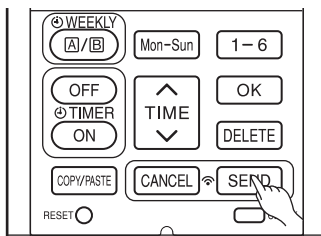

6



## WEEKLY TIMER OPERATION

### Step 3: Copy and cancel the reservation schedule.

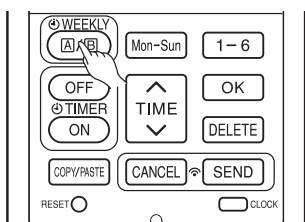

1

[Delete one day reservation]

1. Press (WEEKLY) button to select Mode A or Mode B.

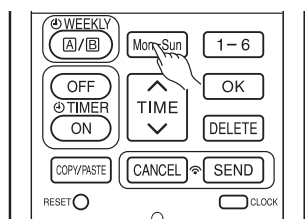

2

2. Press (WEEKLY) button for 3 seconds to start editing the reservation schedule.

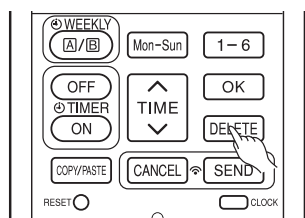

3

3. Press (DAY) button to select a day of the week to edit.

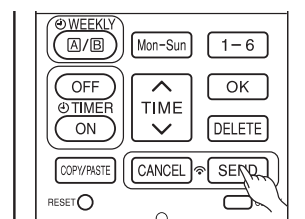

4

4. Press (DELETE) button for about 10 seconds. Reservations for all program numbers will be deleted.

- If press for a short time, reservation for one program number will be deleted.

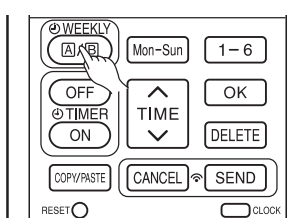

5

5. After deleting, press (SEND) button while directing the remote controller towards the indoor unit for about 3 seconds. Timer lamp on the indoor unit will blink rapidly.

After beep sound emitted from indoor unit, TIMER lamp will light up.

**Please ensure that the TIMER lamp lights up.**

- Reservation will not change if (SEND) button is not pressed.

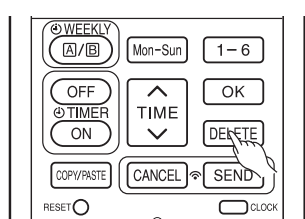

1

[Delete Mode A or Mode B]

1. Press (WEEKLY) button to select Mode A or Mode B.

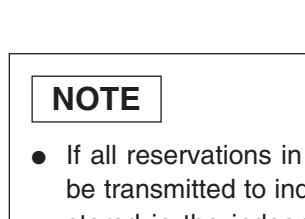

2



2. Direct the remote controller towards the indoor unit and press (DELETE) button for about 10 seconds while Mode A or Mode B display blinks.

After beep sound emitted from indoor unit, reservations for Mode A or Mode B will disappear.

#### NOTE

- If all reservations in the remote controller were deleted and pressed (SEND) button, no signal will be transmitted to indoor unit. TIMER lamp will remain off and no changes will be done to the reservations stored in the indoor unit.

## INFO FUNCTION

- By pressing  (INFO) button, temperature around remote controller and monthly power consumption will be displayed on the remote controller.
- After changing the batteries, direct the remote controller towards the indoor unit and press  (INFO) button. Current calendar and clock will be transmitted from indoor unit.
- In order to receive information from indoor unit, the distance between remote controller and receiver of indoor units is within 2 meters.

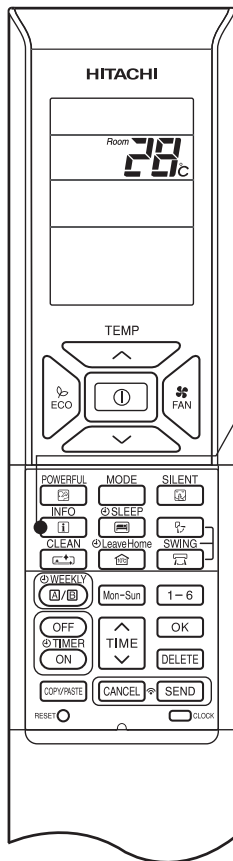

### ■ To check temperature around remote controller

1

Press  (INFO) button.

Temperature will be displayed for 10 seconds.

### ■ To check monthly power consumption

Direct the remote controller towards the receiver of indoor unit (within 2 meters in front of indoor unit) and press  (INFO) button. Wait for 2 seconds for signal transmission.

While temperature around remote controller is displayed, press  (INFO) button repeatedly. The display will show as below:

this month power consumption amount for heating → last month power consumption amount for heating → this month power consumption amount for cooling → last month power consumption amount for cooling → temperature around remote controller → this month power consumption amount for heating ..... cyclically.

- If indication is not given, bring remote controller closer to the receiver of the indoor unit.
- Indicated value shall be regarded as a guide only.



### ■ Current calendar and clock can be retrieved from indoor unit

Direct the remote controller towards the receiver of indoor unit (within 2 meters in front of indoor unit) and press  (INFO) button. Wait for 2 seconds for signal transmission.

Once received the current calendar and clock, check whether they are correct or not by pressing  (CLOCK) button.

- If there is no power supply to indoor unit or calendar and clock have not been set, INFO function cannot be used for sending or receiving information.

### NOTE

- In case failure occurs to the air conditioner, by pressing  (INFO) button, an error code will be displayed. Direct the remote controller towards the receiver of indoor unit (within 2 meters in front of indoor unit) and press  (INFO) button. Wait for 2 seconds for signal transmission. An error code will be displayed. Call service center and inform the error code.
- Information of "Monthly power consumption" is not available for 6 rooms multi system.
- Info Function to check monthly power consumption. During installation, in case of power failure or breaker ON / OFF, ensure to set the clock and calendar for each indoor unit (unit in standby mode or auto restart), for single or multi connection, by pressing  (START / STOP) button. Failure to do the above, monthly power consumption amount will not be displayed on the remote controller.

# OPERATION MODE LOCK

The remote controller can be set to fix the HEATING mode (including FAN), COOLING mode (including FAN) and DEHUMIDIFYING mode (including FAN) operations.

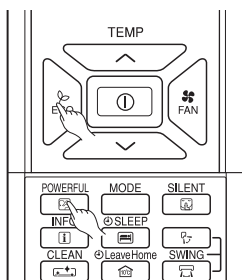

Method to lock HEATING mode (including FAN) operation.

Press (ECO) and (POWERFUL) buttons simultaneously for about 5 seconds when the remote controller is OFF.

“”, “” and “” will be displayed for about 10 seconds. Later, “” and “” will remain.

This indicates that HEATING mode operation is locked.

When pressing (MODE) button, “” or “” will be displayed.

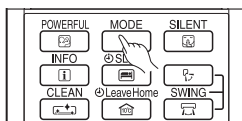

Method to unlock HEATING mode (including FAN) operation.

Press (ECO) and (POWERFUL) buttons simultaneously for about 5 seconds when the remote controller is OFF.

All operation mode symbols will appear on the display for about 10 seconds. After that, operation mode symbol before cancellation will be displayed.

This indicates that HEATING mode operation is unlocked.

Method to lock COOLING and DEHUMIDIFYING modes (including FAN) operations.

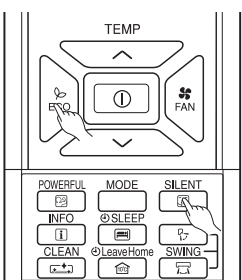

Press (ECO) and (SILENT) buttons simultaneously for about 5 seconds when the remote controller is OFF.

“”, “”, “” and “” will be displayed for about 10 seconds. Later, “” and “” will remain.

This indicates that COOLING and DEHUMIDIFYING mode operation is locked.

When pressing (MODE) button, “”, “” or “” will be displayed.

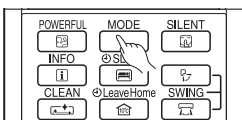

Method to unlock COOLING and DEHUMIDIFYING modes (including FAN) operations.

Press (ECO) and (SILENT) buttons simultaneously for about 5 seconds when the remote controller is OFF.

All operation mode symbols will appear on the display for about 10 seconds. After that, operation mode symbol before cancellation will be displayed.

This indicates that COOLING and DEHUMIDIFYING modes operation is unlocked.

## NOTE

- Operation Mode Lock function will not activate if TIMER reservations activate. TIMER reservations shall be deactivated first. Then, Operation Mode Lock function can be activated.
- HEATING, COOLING and DEHUMIDIFYING mode (including FAN) operations can be unlocked by pressing the (RESET) button. However, by pressing the (RESET) button, all the information stored in the remote controller will disappear. You may need to set the necessary information again.
- For multi connections, unit and mode which is set to lock HEATING and switched on first shall have higher priority. Other units which are chosen to operate at different modes shall be in STANDBY until either the first unit operation is switched off or the mode is selected to be same as the first unit.

## MAINTENANCE

### **⚠ CAUTION**

Cleaning and maintenance must be carried out only by qualified service personal. Before cleaning, stop operation and switch off the power supply.

### 1. AIR FILTER

Please clean the filter once about every two weeks. By doing so, the power rates are saved. In case the air filter is full of dust, the air flow will decrease and the cooling capacity will be reduced. Further, noise may occur. Be sure to clean the filter following the procedure below.

#### **PROCEDURE**

- 1** Open the front panel carefully and remove the filter.

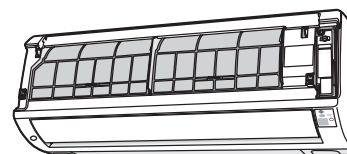

- 2** Vacuum dust from the air filter using vacuum cleaner. If there is too much dust, wash the filter with a detergent and rinse it thoroughly. After that, dry it in the shade.

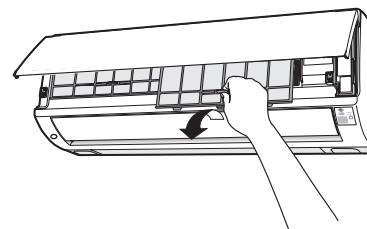

- 3**
- Set the filter with "FRONT" mark facing front, and slot them into the original state.
  - After attaching the filters, push the front panel at three arrow portions as shown in figure and close it.

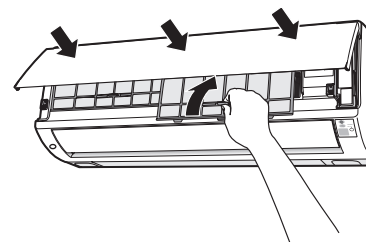

### **⚠ CAUTION**

- Do not wash with hot water at more than 40°C. The filter may shrink.
- When washing it, shake off moisture completely and dry it in the shade; do not expose it directly to the sun. The filter may shrink.
- Don't operate the unit without filter. Fault may occur if you continue.



## 2. CLEANING OF FRONT PANEL

- Remove the front panel and wash with clean water. Wash it with a soft sponge. After using neutral detergent, wash thoroughly with clean water.
- When front panel is not removed, wipe it with a soft dry cloth. Wipe the remote controller thoroughly with a soft dry cloth.
- Wipe the water thoroughly. If water remains at indicators or signal receiver of indoor unit, it causes trouble.

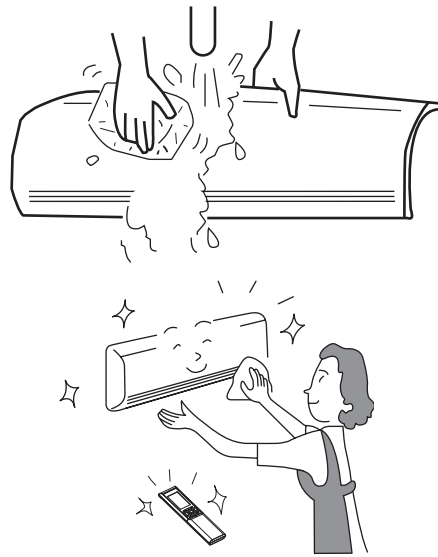

Method of removing the front panel.  
Be sure to hold the front panel with both hands to detach and attach it.

### Removing the Front Panel

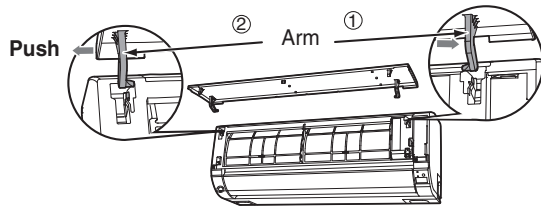

1. Push the end of the right-side arm outward to release the tab.
2. Move the left-side arm outward to release the left tab, and then pull the panel towards you.

### Attaching the Front Panel

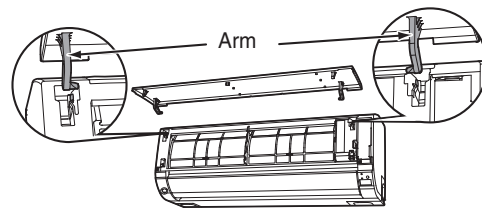

1. Insert the shaft of the left arm along the step on the unit into the hole.
2. Securely insert the shaft of the right arm along the step on the unit into the hole.
3. Make sure that the front panel is securely attached, and then close the front panel.

### ⚠ CAUTION

- Do not splash or direct water to the body of the unit when cleaning it as this may cause short circuit.
- Never use hot water (above 40°C), benzine, gasoline, acid, thinner or a brush, because they will damage the plastic surface and the coating.



## 3. MAINTENANCE AT BEGINNING OF LONG OFF PERIOD

- Run the unit by setting the operation mode to (FAN) and the fan speed to HI for about half a day on a fine day, and dry the whole of the unit.
- Switch off the power plug or turn off the circuit breaker.

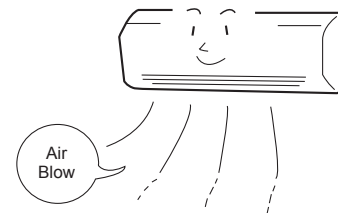

## INFORMATION

### CAPABILITIES

#### Heating Capability

- This room air conditioner utilizes a heat pump system that absorbs exterior heat and brings it into a room to be heated. As the ambient temperature gets lower, heating capability will also lower. In such a situation, the inverter works to increase compressor rpm to keep the unit's heating capability from decreasing. If the unit's heating performance is still unsatisfactory, other heating appliances should be used to augment this unit's performance.
- The air conditioner is designed to heat an entire room so that it may take some time before you feel warm. Timer operation is recommended for effective preheating ahead of the desired time.

#### Cooling and Dehumidifying Capabilities

- If the heat present in a room exceeds the unit's cooling capacity (for example, if there are many people in the room or other heating appliances are used), the preset room temperature may not be reached.

#### CAUTION

Do not use a stove or any other high-temperature devices in proximity to the indoor unit.







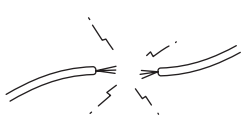

### REFRIGERANT INFORMATION

- **For the refrigerant charge information, please refer to the outdoor unit installation manual or specification label.**

## REGULAR INSPECTION

PLEASE CHECK THE FOLLOWING POINTS EVERY EITHER HALF YEARLY OR YEARLY. CONTACT YOUR SALES AGENT SHOULD YOU NEED ANY HELP.

1		 WARNING	Check to see if the unit's earth line has been connected correctly. If the earth line is disconnected or faulty, unit failure or electric shock hazard may result.
2		 WARNING	Check to see if the mounting frame has rusted excessively or if the outdoor unit has tilted or become unstable. It could collapse or fall, causing injury.
3		 WARNING	Check to see if the power plug is securely inserted into the wall socket. If the power plug is not inserted into the wall socket securely or becomes hot, an electric shock or fire may result. If dust or dirt is found on the power plug, clean the plug and insert it into the wall socket.

## AFTER SALES SERVICE AND WARRANTY

WHEN ASKING FOR SERVICE, CHECK THE FOLLOWING POINTS.

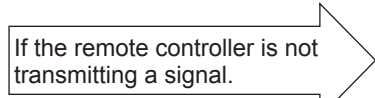
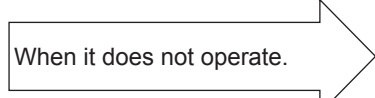
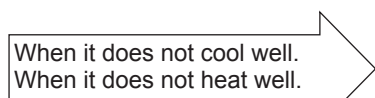
CONDITION	CHECK THE FOLLOWING POINTS
 If the remote controller is not transmitting a signal. (Remote controller display is dim or blank.)	<ul style="list-style-type: none"> <li>Do the batteries need replacement?</li> <li>Is the polarity of the inserted batteries correct?</li> </ul>
 When it does not operate.	<ul style="list-style-type: none"> <li>Is the fuse all right?</li> <li>Is the voltage extremely high or low?</li> <li>Is the circuit breaker "ON"?</li> <li>Is the power plug inserted?</li> <li>Do you have any power cut?</li> </ul>
 When it does not cool well. When it does not heat well.	<ul style="list-style-type: none"> <li>Is the air filter blocked with dust?</li> <li>Is the set temperature suitable?</li> <li>Have horizontal air deflectors been adjusted to their correct positions according to the operation mode selected?</li> <li>Are the air inlets or air outlets of indoor and outdoor units blocked?</li> <li>Is the fan speed "LOW" or "SILENT"?</li> </ul>

■ The following phenomena do not indicate unit failure.

During heating, the operation indicator blinks and air blow stops	<Operation start> The unit is preparing to blow warm air. Please wait. <In operation> The outdoor unit is defrosting. Please wait.
Hissing or fizzy sounds	Refrigerant flow noise in the pipe or valve sound generated when flow rate is adjusted.
Squeaking noise	Noise generated when the unit expands or contracts due to temperature changes.
Rustling noise	Noise generated with the indoor unit fan's rpm changing such as operation start times.
Clicking noise	Noise of the motorized valve when the unit is switched on.



Perking noise	Noise of the ventilation fan sucking in air present in the drain hose and blowing out dehumidifying water that had accumulated in the condensed water collector. For details, consult your sales agent.
Changing operation noise	Operation noise changes due to power variations according to room temperature changes.
Mist emission	Mist is generated as the air within the room is suddenly cooled by conditioned air.
Steam emitted from the outdoor unit	Water generated during defrosting operation evaporates and steam is emitted.
Odors	Caused as the smells and particles of smoke, food, cosmetics, etc. present in room air become attached the unit and blown off into the room again.
The outdoor unit continues to operate even if operation is stopped.	Defrosting is underway (as the heating operation is stopped, the microcomputer checks frost accumulated in the outdoor unit and instructs the unit to perform automatic defrosting if necessary).
The OPERATION lamp is blinking.	Shows preheating or defrosting operation is underway. As the protective circuit or preheat sensor operates when unit operation is stopped during preheating and then restarted, or when operation mode is switched from cooling to heating, the lamp continues to blink.
Does not reach the temperature setting	Actual room temperature may deviate slightly from the remote controller's temperature setting depending on the number of people in the room, indoor or outdoor conditions.

- If the unit still fails to operate normally after performing the above inspections, turn the circuit breaker off, or pull the power plug out, and contact your sales agent immediately.

Contact your sales agent immediately if the following phenomena should occur:

- The circuit breaker switches off or the fuse blows frequently.
- The switch operation is not stable.
- Foreign matter or water accidentally enters the unit interior.
- The power cord gets excessively hot or its insulation is torn or stripped.
- TIMER lamp on the indoor unit display blinks.



( As the nature of the failure can be identified by the blinking cycle, check the blinking cycle before turning off the circuit breaker. )



#### Notes

- In quiet operation or stopping the running, the following phenomena may occasionally occur, but they are not abnormal for the operation.
  - (1) Slight flowing noise of refrigerant in the refrigerating cycle.
  - (2) Slight rubbing noise from the fan casing which is cooled and then gradually warmed as operation stops.
- The odor will possibly be emitted from the room air conditioner because the various odor, emitted by smoke, foodstuffs, cosmetics and so on, sticks to it. So please clean the air filter and the evaporator regularly to reduce the odor.

- Please contact your sales agent immediately if the air conditioner still fails to operate normally after the above inspections. Inform your agent of the model of your unit, production number, date of installation. Please also inform him regarding the fault.

#### Please note:

On switching on the equipment, particularly when the room light is dimmed, a slight brightness fluctuation may occur. This is of no consequence.

The conditions of the local Power Supply Companies are to be observed.









