

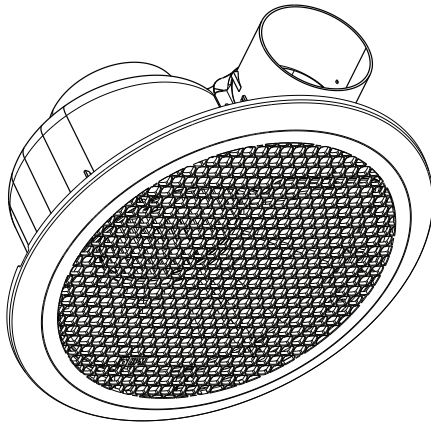

Ceiling Exhaust Fan - Ducted

Cat. No. EFD01RDWE, EFD01RDMS, EFD01SQWE

Instruction Manual



EFD01RDWE/ EFD01RDMS

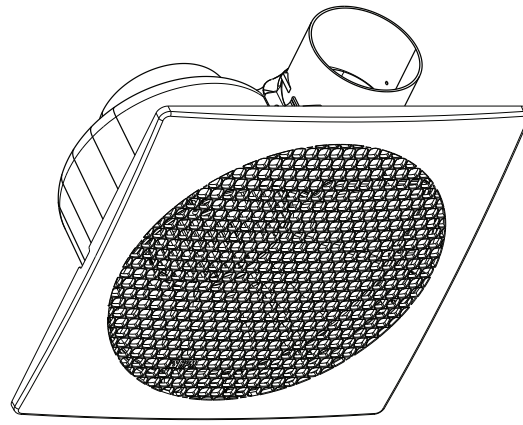

EFD01SQWE

Specifications

| Cat No | EFD01RDWE | EFD01RDMS | EFD01SQWE |
|---|-----------------------|-------------|--------------|
| Colour | White | Matt Silver | White |
| Supply Voltage | 230-240V a.c 50Hz | | |
| Power Rating | 40W max | | |
| Max Airflow Rate (Non-ducted) | 330m ³ /hr | | |
| Max Airflow Rate (Ducted – Ø150mm x 3m) | 250m ³ /hr | | |
| Protection Class | Class II | | |
| Duct Requirement | Ø150mm | | |
| Ceiling Cut-out Size | Ø298mm | | |
| Projection into Ceiling | 190mm | | |
| Protrusion from Ceiling | 26mm | | |
| Grille Size | Ø372mm | | 350 x 350 mm |

Please read carefully

Read through these instructions completely before commencing installation. Retain for future use.

1. This product shall be installed in accordance to AS/NZS 3000 Wiring Rules.
2. Regulations concerning the discharge of air must be fulfilled. Local building codes may require venting to the outside.
3. This product must be installed at least 2.2m above floor level.
4. Do not install within 120cm of a stove or inside a shower recess.
5. Cross Ventilation:

Ventilation products must have an adequate source of external air to ensure rated performance.

Steam and air will only be exhausted through the fan if there is sufficient flow of air through the room. Ensure adequate inlets exist through windows, vents or under the door. Airflow path from the inlet to the fan should ideally pass over the source of steam or air to be removed from the room.

Restrictions on replacement air entering the room to be ventilated, or pressure-differentials between the room and outside air will significantly reduce the exhaust fan's performance.

6. Compliance with Section 6 Damp Situation of AS/NZS 3000 Wiring Rules:

No part of the unit may be located directly above any part of the bath or shower recess or enclosure.

The unit must be installed within zones 2 and 3 only. For further information, refer to AS/NZS 3000.

7. Unit Orientation:

The unit must be installed to ensure the housing outlet and ducting is oriented in parallel to any roofing structures or supports. Refer to image below for correct installation orientation. Orientation which forces the unit to be ducted into a 90° bend immediately after the fan outlet will cause a significant performance reduction.

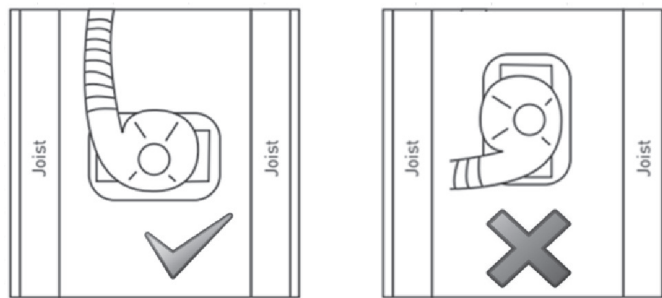

8. Duct Size and Length:

The unit must be installed with $\varnothing 150\text{mm}$ duct using the adaptor supplied to ensure optimum extraction and performance. The maximum recommended duct length is 3m. The graph below shows the unit's performance with 3m of duct. Longer ducts will reduce the unit's performance.

9. Duct Routing:

As the back pressure increases the unit's performance is reduced. Airflow will be reduced with bends in duct or squashing of duct. Every 90° bend/elbow results in approx 20% reduction in the unit's performance.

Please refer to the graph below, an almost linear relationship between back pressure and fan performance proves just how critical correct installation of the exhaust fan is in relation to performance.

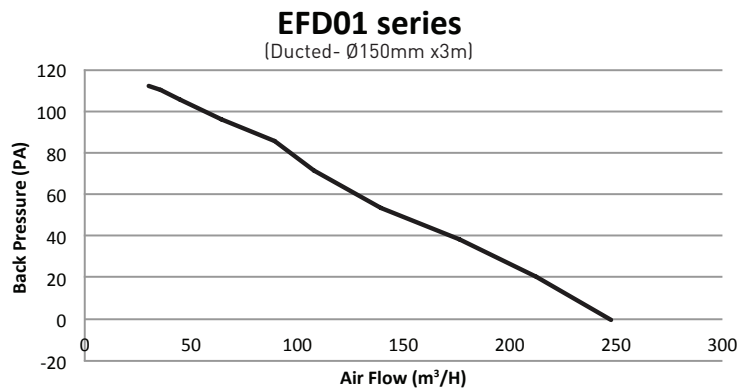

The unit shall be installed horizontally in the ceiling in accordance with example images shown below to ensure intended operation and rated performance. When fitted, the duct outlet must be the same height or lower than the exhaust fan.

The duct must not be installed vertically into a roof vent cap - the product is not designed or intended for this type of installation.

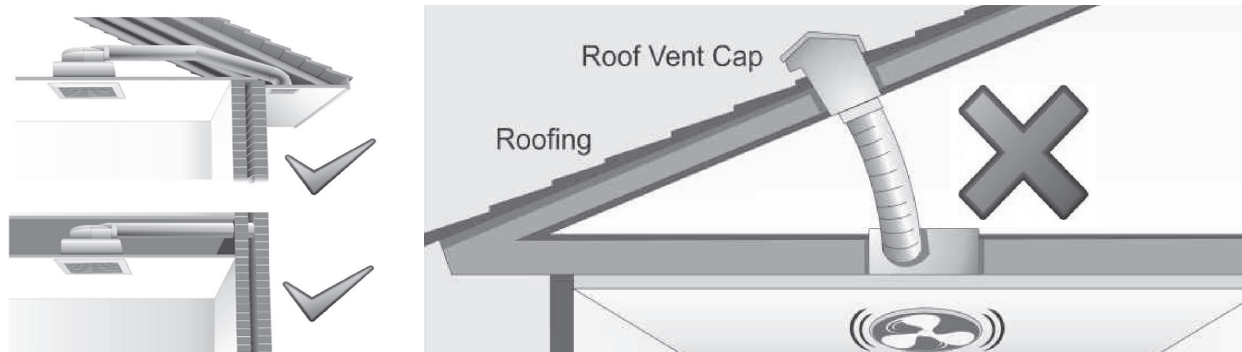

Installation

1. Determine position in ceiling where the exhaust fan is required to be installed (figure 1).
2. Use the template provided to draw a circle. To do this, insert a thumb tack at one end and insert a pencil at the other end and scribe a circle (figure 2).
3. Cut out around this line (figure 3).
4. Remove grille from the exhaust fan.
5. Attach duct adaptor to duct with duct tape (figure 4).
6. Ensure that a power outlet is installed in the ceiling near the intended position of the exhaust fan. Ensure that power to the outlet is off. Plug the exhaust fan into this outlet (figure 5).
7. Attach duct adaptor to the exhaust fan outlet (figure 6).
8. Insert the unit into the cavity (figure 7).
9. With the unit in place, turn the toggles (4x) clockwise and tighten the screws until the clamps securely grip the ceiling (figure 8).
10. Push grille onto unit and click into position (figure 9).

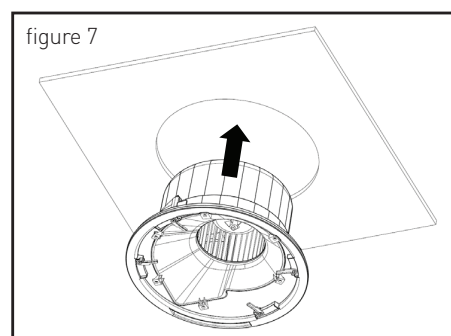
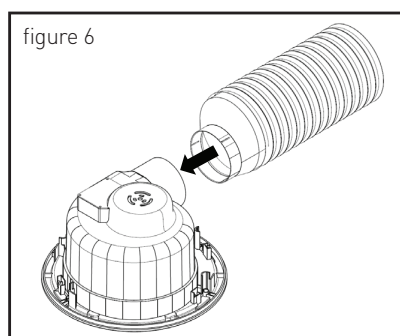
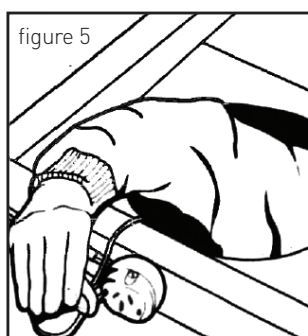
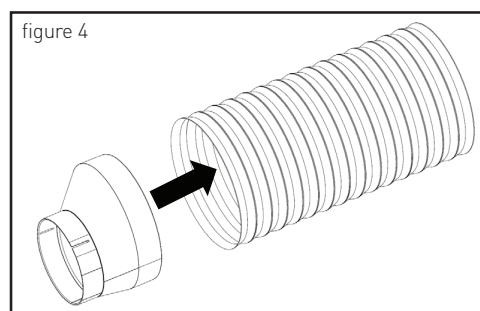
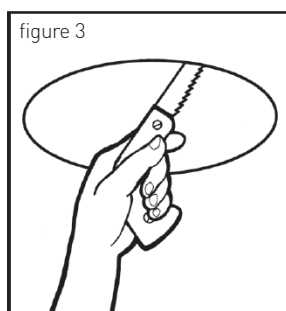
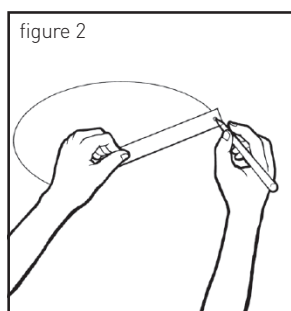
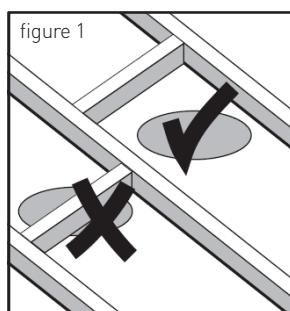

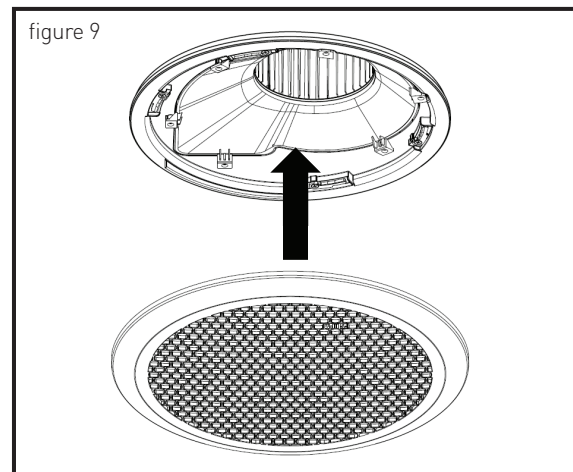
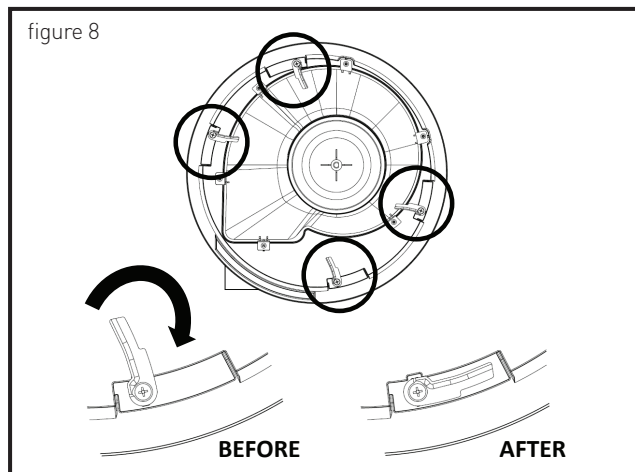

Disclaimers

1. This product must be installed and used as per these instructions.
2. This product should only be cleaned with a damp cloth. Cleaning agents and solvents should not be used.
3. This product is not intended for use by persons (including children) with reduced physical, sensory or mental capabilities, or lack of experience and knowledge, unless they have been given supervision or instruction concerning use of the appliance by a person responsible for their safety. Children should be supervised to ensure that they do not play with the appliance.
4. This product is intended for household use and similar purposes. It is not suitable for use in an environment heavily laden with dust. Under these conditions the life of the fan motor can be significantly reduced.
5. This product should not be enclosed in thermal insulation as it may cause the unit to overheat.
6. This product has been designed to operate in ambient temperatures -10°C to 40°C.
7. This product contains no serviceable parts and no attempt should be made to repair it. If the product is faulty it should be discarded.
8. Airflows listed in this product indicate the product performance. Refer to the BCA (Building Code of Australia), or similar, for the appropriate airflow required for a particular installation.
9. Ventilation products must have an adequate source of external air to ensure correct performance.
10. Consideration must be taken in the installation of ducts to ensure that condensation that will form in the duct will not run back into the fan housing.
11. Precautions must be taken to avoid the back-flow of gases into the room from the open flue of gas or other fuel-burning appliances.
12. This product has been designed for domestic or similar uses and is not suitable for a commercial installation.
13. This product is not suitable for installation in hazardous and/or corrosive areas.
14. The material in this product may vary in colour from batch to batch. Colour matching from one batch to another cannot be guaranteed.
15. This product utilises intellectual property in the form of registered designs, trademarks, and/or patents. Such intellectual property remains the property of HPM Legrand in all cases.
16. HPM Legrand reserves the right to modify the specification of this product at any time.

Warranty

HPM Legrand warrants this product for a period of 3 years from the date of purchase.

These goods come with guarantees that cannot be excluded under the Australian and New Zealand Consumer Laws. You are entitled to a replacement or a refund for a major failure and for compensation for any other reasonably foreseeable loss or damage. You are also entitled to have the goods repaired if the goods fail to be acceptable quality and the failure does not amount to a major failure.

See the Warranty card enclosed with this product for further details.

Customer Service

For all Customer Service and Technical Support please call Monday to Friday during business hours.

HPM Legrand Australia
1300 369 777
www.hpm.com.au

HPM Legrand New Zealand
0800 476 009
www.hpm.co.nz

ABN: 31 000 102 661

A Group brand | 