

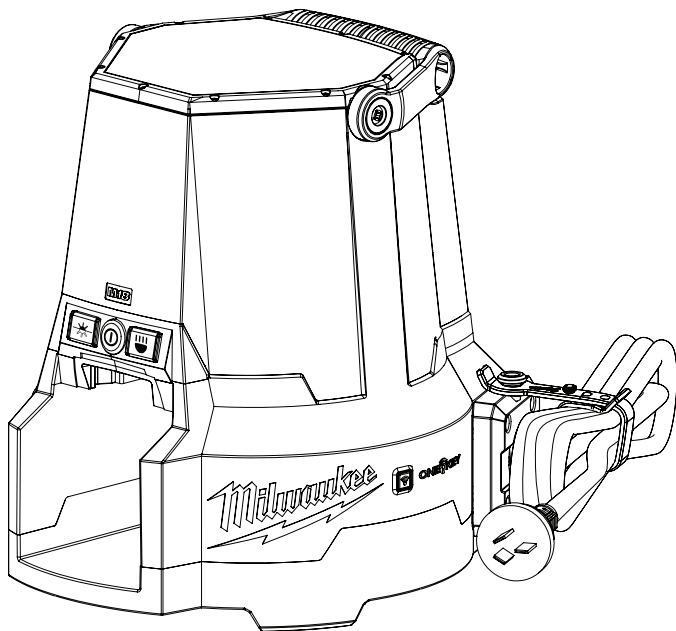

OPERATOR'S MANUAL



Cat. No.
M18 ONESLSP

M18™ LED COMPACT SITE LIGHT WITH ONE-KEY™

 **WARNING**

To reduce the risk of injury, user must read and understand operator's manual.



IMPORTANT SAFETY INSTRUCTIONS

WARNING

Read all safety warnings and all instructions. Failure to follow the warnings and instructions may result in electric shock, fire and/or serious injury. Save all warnings and instructions for future reference.

WORK AREA SAFETY

- To reduce the risk of injury, close supervision is necessary when an appliance is used near children.
- Store idle light out of reach of children. Warm lights can become hazardous in the hands of children.

ELECTRICAL SAFETY

- Power cord plugs must match the outlet. Never modify the plug in any way. Do not use any adapter plugs with earthed (grounded) power tools. Unmodified plugs and matching outlets will reduce risk of electric shock.
- Avoid body contact with earthed or grounded surfaces, such as pipes, radiators, ranges and refrigerators. There is an increased risk of electric shock if your body is earthed or grounded.
- Suitable for rain and wet locations. Store indoors. Water and dust resistant.
- To reduce the risk of electric shock, do not put light in water or other liquid. Do not place or store appliance where it can fall or be pulled into a tub or sink.
- Do not abuse the cord. Never use the cord for carrying, pulling or unplugging the power tool. Keep cord away from heat, oil, sharp edges or moving parts. Damaged or entangled cords increase the risk of electric shock.
- Arrange cords carefully to avoid hazardous environments. Tripping or snagging on cords can cause injury and product damage. Do not allow cords to run through puddles or across wet ground.
- Do not unplug by pulling on the cord. To unplug, grasp the plug, not the cord.
- Unplug the cord from outlet when not in use and before servicing or cleaning.
- Always use a suitable extension cord to reduce the risk of electric shock.
- If operating a light in a damp location is unavoidable, use a residual current device (RCD) protected supply. Use of a RCD reduces the risk of electric shock.

PERSONAL SAFETY

- Do not overreach. Keep proper footing and balance at all times. This enables better control of the light in unexpected situations.
- Do not use on a ladder or unstable support. Stable footing on a solid surface enables better control of the light in unexpected situations.

BATTERY TOOL USE AND CARE

- Recharge only with the charger specified by the manufacturer. A charger that is suitable for one type of battery pack may create a risk of fire when used with another battery pack.
- Use light only with specifically designated battery packs. Use of any other battery packs may create a risk of injury and fire.
- When battery pack is not in use, keep it away from other metal objects, like paper clips, coins, keys, nails, screws or other small metal objects, that can make a connection from one terminal to another. Shorting the battery terminals together may cause burns or a fire.
- Under abusive conditions, liquid may be ejected from the battery; avoid contact. If contact accidentally occurs, flush with water. If liquid contacts eyes, additionally seek medical help. Liquid ejected from the battery may cause irritation or burns.
- Do not use a battery pack or tool that is damaged or modified. Damaged or modified batteries may exhibit unpredictable behavior resulting in fire, explosion or risk of injury.
- Do not expose a battery pack or tool to fire or excessive temperature. Exposure to fire or temperature above 130°C (265°F) may cause explosion.
- Follow all charging instructions and do not charge the battery pack or tool outside the temperature range specified in the instructions. Charging improperly or at temperatures outside the specified range may damage the battery and increase the risk of fire.

SERVICE

- Have your light serviced by a qualified repair person using only identical replacement parts. This will ensure that the safety of the light is maintained.
- Never service damaged battery packs. Service of battery packs should only be performed by the manufacturer or authorised service providers.

SPECIFIC SAFETY RULES

- Chemical Burn Hazard. Keep batteries away from children.
- This tool contains a lithium button/coin cell battery. A new or used battery can cause severe internal burns and lead to death in as little as 2 hours if swallowed or enters the body. Always secure the battery cover with all screws. If it does not close securely, stop using the tool, remove the batteries, and keep it away from children. If you think batteries may have been swallowed or entered the body, seek immediate medical attention.
- Maintain labels and nameplates. These carry important information. If unreadable or missing, contact a MILWAUKEE® service facility for a replacement.

ADDITIONAL SAFETY WARNINGS

If the external flexible cable or cord of this luminaire is damaged, it shall be exclusively replaced by the manufacturer, service agent or a similar qualified person in order to avoid a hazard.

The light source contained in this luminaire shall only be replaced by the manufacturer, service agent or a similar qualified person.





Install with suitable protection box for the plug or use indoor only.

SPECIFICATIONS

Cat. No.	M18 ONESLSP
Ingress Protection.....	IP54 (AC output door closed) IP40 (AC output door open)
Battery Type	M18™
Charger Type.....	M18™
DC Input Volts.....	18
DC Input Amps.....	2.8
AC Input Volts.....	220-240
AC Output Volts.....	220-240
AC Input Amps.....	0.25
AC Output Amps.....	9.75*

*Reduce AC Output Amps by 1A per additional light added in sequence

SYMBOLOLOGY

	Volts
	Direct Current
	Alternating Current
	Regulatory Compliance mark (RCM). This product meets applicable regulatory requirements.

 **CAUTION** Bright Light -
Do Not Stare Into Light

 Read operator's manual

 Class II, double insulated

Do not dispose of electric tools together with household waste material. Electric tools and electronic equipment that have reached the end of their life must be collected separately and returned to an environmentally compatible recycling facility.



FUNCTIONAL DESCRIPTION

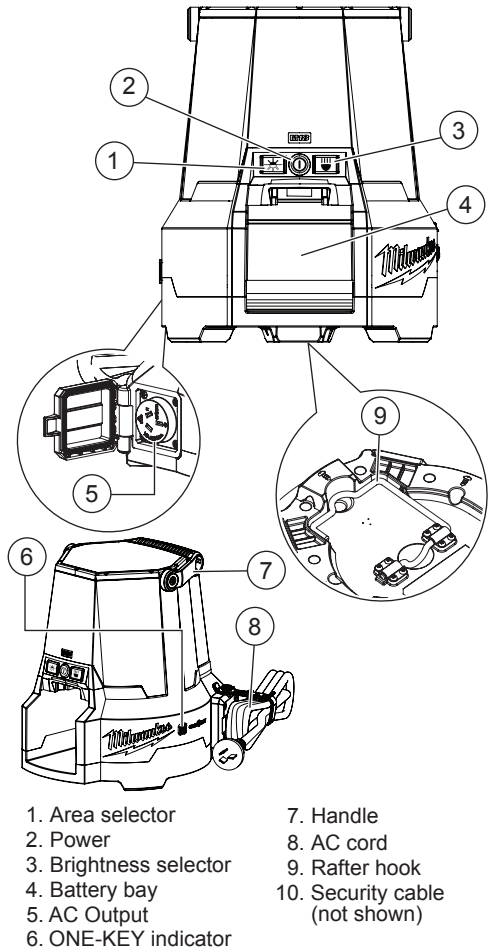

- | | |
|------------------------|-----------------------------------|
| 1. Area selector | 7. Handle |
| 2. Power | 8. AC cord |
| 3. Brightness selector | 9. Rafter hook |
| 4. Battery bay | 10. Security cable
(not shown) |
| 5. AC Output | |
| 6. ONE-KEY indicator | |

EXTENSION CORDS

Grounded tools require a three wire extension cord. As the distance from the supply outlet increases, you must use a heavier gauge extension cord. Using extension cords with inadequately sized wire causes a serious drop in voltage, resulting in loss of power and possible tool damage.

Guidelines for Using Extension Cords

- If you are using an extension cord outdoors, be sure it is marked with the suffix "W" to indicate that it is acceptable for outdoor use.
- Be sure your extension cord is properly wired and in good electrical condition. Always replace a damaged extension cord or have it repaired by a qualified person before using it.
- Protect your extension cords from sharp objects, excessive heat and damp or wet areas.

**READ AND SAVE ALL INSTRUCTIONS
FOR FUTURE USE.**

ASSEMBLY

⚠WARNING Recharge only with the charger specified for the battery. For specific charging instructions, read the operator's manual supplied with your charger and battery.

Inserting/Removing the Battery

Insert the battery pack by sliding battery pack into the body of the tool. Insert the battery pack until the battery latches lock.

To remove the battery pack, press in both battery latches and slide the battery pack off of the tool.

1. When power is supplied by AC input, light operates from DC power supply.
2. When AC input power is not present, light receives power from battery.
3. No current from DC power supply is allowed to flow into battery such that battery would receive charge current.
4. Switching between DC power supply and battery power occurs automatically upon application or removal of AC input power.

ONE-KEY™

To learn more about the ONE-KEY functionality for this tool, please reference the Quick Start guide included with this product or go to www.milwaukeetools.com.au/One-Key / www.milwaukeetools.co.nz/One-Key. To download the ONE-KEY app, visit the App Store or Google Play from your smart device.

OPERATION

⚠WARNING To reduce the risk of injury, do not look directly into the light when the light is on.

Using the Light

1. Insert battery pack or plug into AC power.
2. Press the Power **ⓘ** button to turn on the light.
3. Press the Brightness **☰** button to cycle through **High** (4400 lumens), **Medium** (2100 lumens), and **Low** (1000 lumens). The light will default to the selected brightness the next time it is turned on.
4. Press the Area Selector **☼** button to select front, back, or full lighting. The light will default to the selected area the next time it is turned on.
5. Press the Power **ⓘ** button to turn the light off.

NOTE: On battery power, the light will flash to indicate the battery is reaching end-of-charge.

Orientation

The light can be oriented in multiple ways:

- Placing it on its base
- Hanging it upright by the handle
- Hanging it upside down by the rafter hook

Daisy-chain/ String the Lights Together

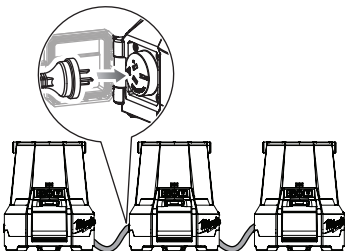

MAINTENANCE

⚠WARNING To reduce the risk of injury, always unplug the tool and charger and remove the battery pack from the charger or tool before performing any maintenance. Never disassemble the tool, battery pack or charger. Contact a MILWAUKEE® service facility for ALL repairs.

Maintain Light

Keep your light, battery pack and charger in good repair by adopting a regular maintenance program. If the light does not work properly, return the light to a MILWAUKEE® service facility for repairs.

Internal Battery

An internal battery is used to facilitate full ONE-KEY™ functionality.

To replace the battery:

1. Remove the battery pack and all extension cord connections.
2. Turn the tool over and remove the five screws holding the lens onto the base, as indicated by the screw symbols on the bottom of the tool. Do not remove the other screws in the base.
3. Remove the lens.
4. Remove the two screws holding the coin cell battery cover in place.
5. Remove the old battery. **WARNING!** Always keep batteries away from children and dispose of properly; new and used batteries can cause injury.
6. Insert the new battery.
Always use MILWAUKEE® replacement batteries; others may not be rated for high temperatures.
7. Replace the battery cover and tighten screws securely.
8. Replace the lens and tighten the screws securely.

⚠WARNING To reduce the risk of personal injury and damage, never immerse your tool, battery pack or charger in liquid or allow a liquid to flow inside them.

Cleaning

Clean dust and debris from vents. Keep handles clean, dry and free of oil or grease. Use only mild soap and a damp cloth to clean, since certain cleaning agents and solvents are harmful to plastics and other insulated parts. Do not use sprays or solvents. Some of these include gasoline, turpentine, lacquer thinner, paint thinner, chlorinated cleaning solvents, ammonia and household detergents containing ammonia. Never use flammable or combustible solvents around tools.

ACCESSORIES

⚠WARNING Use only recommended accessories. Others may be hazardous.

For a complete listing of accessories, go online to www.milwaukeetools.com.au/ www.milwaukeetools.co.nz or contact a distributor.

WARRANTY - AUSTRALIA and NEW ZEALAND

Please refer to Australian and New Zealand warranty supplied with tool. This warranty applies only to product sold in Australia and New Zealand.

SERVICE - AUSTRALIA and NEW ZEALAND

MILWAUKEE® prides itself in producing a premium quality product that is Nothing But Heavy Duty®. Your satisfaction with our products is very important to us! If you encounter any problems with the operation of this tool, please contact your authorised **MILWAUKEE®** dealer.

For a list of **MILWAUKEE®** dealers, guarantee or service agents please contact **MILWAUKEE®** Customer Service or visit our website.

(Australia Toll Free Telephone Number 1300 645 928)

(New Zealand Toll Free Telephone Number 0800 279 624)

or visit www.milwaukeetools.com.au / www.milwaukeetools.co.nz.

Milwaukee Electric Tool Corporation

13135 West Lisbon Road, Brookfield, Wisconsin U.S.A. 53005

Milwaukee Tool (Australia)

21 Kelletts Road, Rowville, VIC 3178
Melbourne, Australia

Milwaukee Tool (New Zealand)

2 Landing Drive, Mangere
Auckland, 2022, New Zealand

Designed by Milwaukee Electric Tool Corp.

Professionally Made in China for Milwaukee Tool (Australia) / Milwaukee Tool (New Zealand)

Printed in China