

# Installation and Operating Instructions

## Models:

**T7-6S-3**

**T7-9S-3**

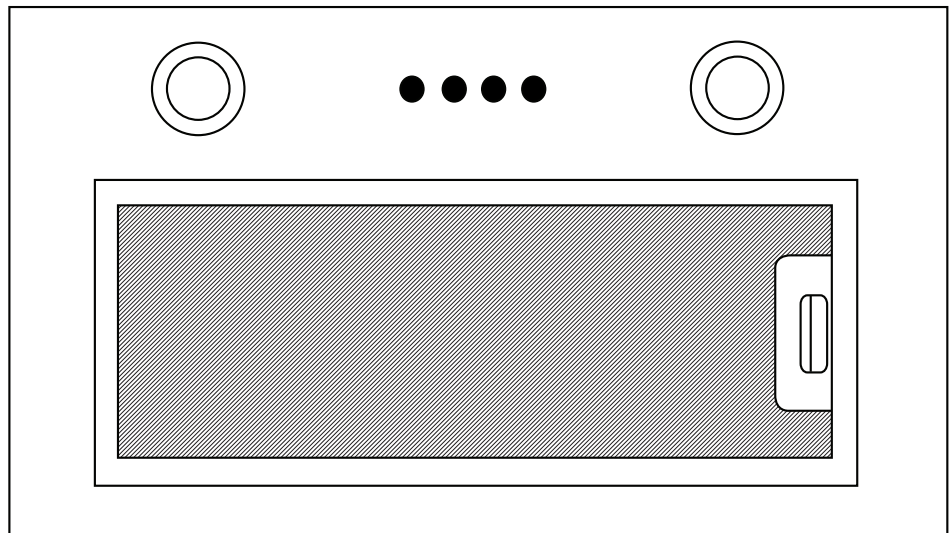

For your convenience, we recommend to attach the serial number label HERE.

As part of Parmco Appliances commitment to improving and updating product ranges, we reserve the right to alter, change and update technical specifications and appearance attributes of all Parmco Appliances products. E&OE.

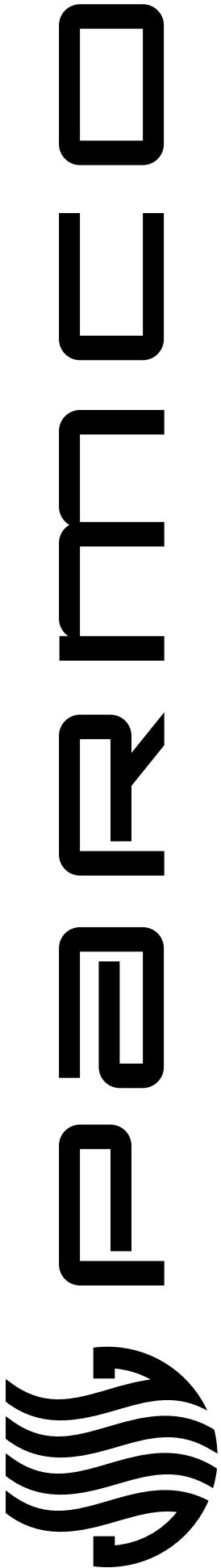



p: 09 573 5678  
 f: 09 573 5699  
 e: sales@parmco.co.nz  
 w: www.parmco.co.nz



# Parmco Appliances extended 7 year warranty

## The Warranty:

- This appliance is intended for domestic use in the owners' home. Use of the appliance for commercial purposes will limit the warranty period (please see Parmco website for commercial details).
- Subject to the terms and conditions contained within this warranty, if the product is not of Acceptable Quality (as defined in the Consumer Guarantees Act) within 7 years of the date of original purchase, then Parmco Sales undertakes to repair or, at its sole discretion, replace the product.
- The warranty does not cover the costs of transport, mileage or travelling time if the product is located beyond 30km of a recognised Service Agent.
- This warranty is offered as an extra benefit, and does not affect other legal rights, which can not be modified or excluded by agreement.
- This warranty only applies to goods supplied and installed in the North and South Islands of New Zealand.
- The provisions of this warranty are in addition to the rights and remedies available to consumers under the Consumer Guarantees Act 1993.

Product \_\_\_\_\_ Date of purchase \_\_\_\_\_  
 Serial Number \_\_\_\_\_  
 Dealer / Retailers Name \_\_\_\_\_  
 \_\_\_\_\_

Please retain this Warranty card together with receipt or other proof of purchase date when seeking service during the warranty period

Please contact Parmco at 09 573 5678 if your appliance needs servicing under warranty. Please have your model number and proof of purchase ready. Warranty repairs must be authorized by Parmco.



## The Warranty is not valid:

- If the product is not installed and operated in accordance with the operating instructions.
- If the product is not installed to comply with the electrical, gas, plumbing and other Regulations and Codes of Practice in New Zealand.
- If the product is operated on voltages or frequencies outside the normal range for domestic appliances in New Zealand.
- If the product is not used in normal domestic use, or if it is used in a business as defined in the Consumer Guarantees Act.
- If any serial number has been removed or defaced.
- If proof of date of purchase is not supplied, except at the sole discretion of Parmco Sales. Proof of purchase can be for the product itself, or if installed with a kitchen or house then proof of purchase can be from a Parmco reseller of products supplied by Parmco.
- If the products are purchased in a second hand condition from other parties (including but not limited to TradeMe, Sella, etc.)

## Liability under this warranty will not be accepted for:

- Wear and tear caused by normal domestic use of the product.
- Damage in transport.
- Damage caused to the product by neglect, abuse, negligence, wilful act or misuse.
- Any costs associated with the repair, replacement, removal or reinstallation of products installed in a damaged condition.
- Any defect caused by accident, misuse, neglect, tampering with or unauthorised modifications of the appliance or any attempt at internal adjustment or repair by any person other than an Authorised Service Agent.
- Service calls that relate principally to the following:
  - Instruction on how to use the product.
  - Repair or replacement of house fuses, electrical wiring, gas fitting or plumbing.
  - Normal or scheduled maintenance including blocked filters or ducting.
  - Consumable items such as light bulbs.
  - Any damage to hobs caused by spills when cooking.
  - Any breakage or damage of glass items.
- Any damage caused by non recommended product used for cleaning, maintaining, lubricating or similar.
- Any aspect relating to the installation of the product, or damage caused during installation including blocked access for repair.
- Any third party (including reseller) or consequential loss or damage (direct or indirect) however arising.



Dear Valued Customer,

Thank you and congratulations on purchasing your new Parmco appliance.

All Parmco products are made to the highest quality and design standards. We are sure you will enjoy your new appliance.

As a note, please read through these instructions carefully, as these will assist you in gaining a complete understanding of the functions and features offered by your appliance.

Please take special note of all detailed technical information and installation instructions. It is essential that you only allow a qualified technician to install this appliance to ensure the safety and reliability of this appliance.

Furthermore, not using appropriate personnel to install this appliance may affect any future warranty claims lodged, so please check with Parmco Appliances before any installation is carried out.

We hope you enjoy your new appliance. If you would like to find out more about this product or any other products in Parmco's extensive range, visit us on the web at [www.parmco.co.nz](http://www.parmco.co.nz).

Regards,  
**The Parmco Team**



Thank you for purchasing this rangehood. Please read the instructions manual carefully before you use the rangehood and retain the manual in a safe place for future reference.

Any installation work must be carried out by a qualified electrician. Before you use the rangehood, make sure that the voltage (V) and the frequency (Hz) indicated on the rangehood are exactly the same as the voltage (V) and the frequency (Hz) in your home.

Parmco will not bear any responsibility for any damages caused by inappropriate installation and usage.

## Functions and Features

- The rangehood is made of high quality materials with a streamlined design according to technical and physical engineering theory, coupled with a high end and luxurious age aesthetic feeling.
- The rangehood is equipped with a large power, low noise electric motor and centrifugal fan. It produces strong suction, low noise, no stick grease filter and is easy to clean.
- The grease filter is easy to remove and clean, and simply wipe lightly to clean the motor and other interior parts.

## Schematic diagram

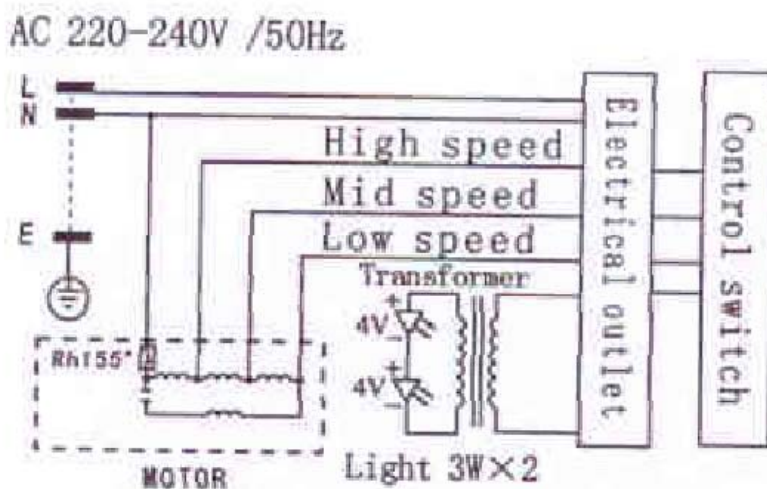

## Installation

1. The rangehood should be placed at a distance of 65cm above an electric cooktop or 75cm above a gas cooktop.
2. Cut a hole in the cupboard of 490x265mm for model T7-6S-3 and 715x265mm for model T7-9S-3. Make sure there is a minimum 35mm gap between the cutout edge and the cupboard edge.
3. Take down the filter and remove the four screws on the side panels of the rangehood.
4. Fix the hood into the cabinet using the screws.
5. Fix the face panel into the body using the screws and reinsert the filter.

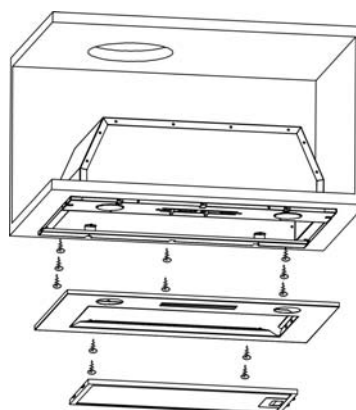
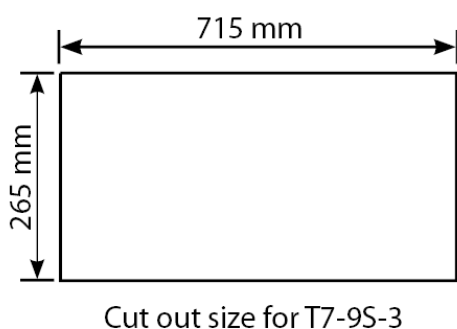
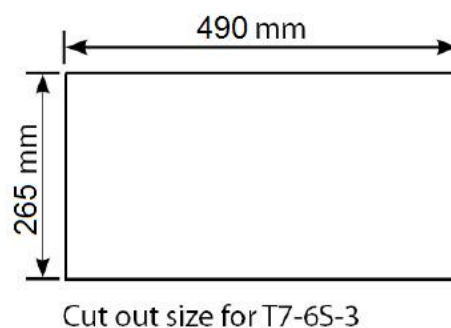
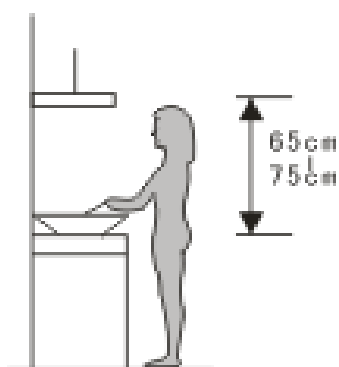

### Changing the Light bulb

Remove the filter, unplug the wiring connector and take out the bulb by pushing the light downwards.

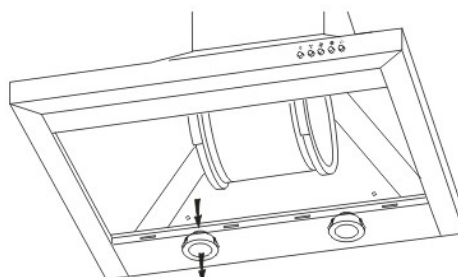

### How to use the Control Panel

1. Turn on the power and the buzzer will buzz five times, indicating the appliance is turned on.
2. Press the "Low" button to run the motor at low speed. Press it again and the motor will stop.
3. Press the "Mid" button to run the motor at medium speed. Press it again and the motor will stop.
4. Press the "High" button to run the motor at high speed. Press it again and the motor will stop.
5. Press the "Light" button to turn on the two lighting lamps. Press it again and the lamps will turn off. With every press, the buzzer will buzz one time.

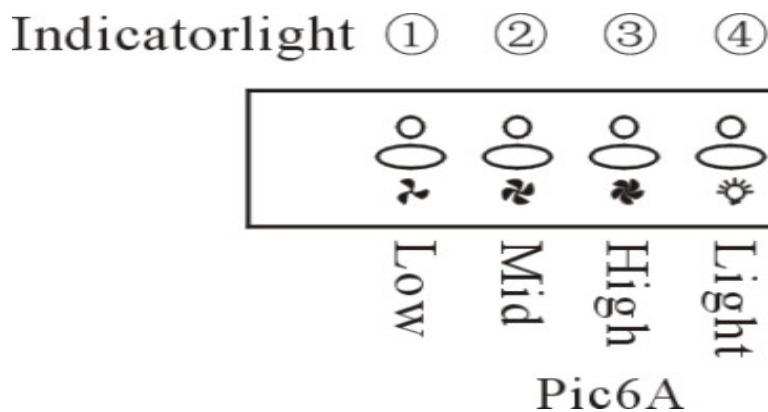

### Maintenance

1. The rangehood and its filter mesh should be cleaned regularly in order to keep it in good working condition. As the grease filters are made of metal, do not clean the filters with detergents that will corrode metal products.
2. Clean the filters as below:  
Method one:  
Put the filter in 40°C-50°C hot water. Pour in some grease-loosening detergent, soak it for about 2-3 minutes and then clean it with a soft brush. Do not brush too hard to avoid damaging the filter.  
Method two:  
Put the filter into a dishwasher with detergent for cleaning. Set the temperature at around 60°C. Be careful not to use detergents that are corrosive to metal products, that is, most dishwasher powders.
3. To protect the main body from corrosion over time, the rangehood should be cleaned with soapy hot water or non corrosive detergent once a week. Do not use grinding detergent as it will damage the body.

4. Keep the motor and other spare parts free from water, as this will cause damage to the appliance.
5. To remove and insert the filter press on the handle as illustrated below.

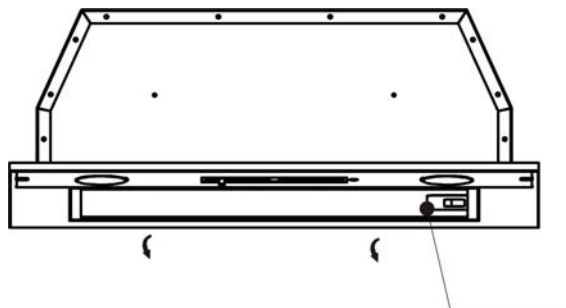

### Attention

- The rangehood uses 220-240V, 50Hz power.
- Cut off the power when you clean.
- Do not expose the filter to fire or flames.
- Do not leave the filter lying around to avoid damage to the filter.
- If there is damage to the plug or plug wire, contact a qualified electrician or professional to replace with the specific flexible wire.

### Technical Reference

Model	T7-6S-3; T7-9S-3
Rated voltage	220-240V 50Hz
Lighting power	3W x 2
Motor power	270W
Duct diameter	150mm
Air flow	1000m <sup>3</sup> /h

### Warning

- Keep your children away from using the rangehood.
- Your rangehood is intended for domestic use only. It is not suitable for barbecue, roast shop or other commercial use.
- Any installation work must be carried out by a qualified electrician or professional person.
- The rangehood and its filter mesh should be cleaned regularly in order to keep it in good working condition.
- Before cleaning, always ensure that you have switched your rangehood off.
- Clean the rangehood according to the instructions manual and keep the

rangehood from any danger of burning.

- Do not dry your rangehood using fire.
- If there are any faults with your rangehood, please call the Parmco service department at 09 573 5678.
- Do not exhaust the air from the rangehood through the same flue as the cooktop or other kitchen appliances.

## Troubleshooting Tips

If any problem occurs, please remove the plug from the socket and contact Parmco service department at 09 573 5678.

<b>Problem</b>	<b>Solution</b>
Lights don't work, but motor works	Change the bulb
	Call Parmco service department
Lights work, but motor does not work	Restart the motor
	Call Parmco service department
Lights don't work, motor doesn't work	Call Parmco service department
The body of the rangehood shakes	Remove obstructions in the ducting
	Make sure the installation is secure
	Call Parmco service department
Insufficient suction	Readjust the distance between the rangehood and the cooktop
	Reduce cross-ventilation or open the window
	Adjust the length of the exhaust pipe
	Check the outlet valve is open
	Call Parmco service department