

Swinburne University of Technology
Centre for Sustainable Infrastructure



ICCONS Thru-Bolt stud anchor testing

January 2017

Report prepared for:
ICCONS Pty. Ltd.

Report by:
Kia Rasekhi and Dr. Jessey Lee

EXECUTIVE SUMMARY

Swinburne University of Technology was commissioned by ICCONS to carry out testing of M12×135mm Thru-Bolt stud anchors according to Clause 7.5.12.3 of NZS 3604:2011 requirements for external walls. The purpose of the tests was to assess tension, shear in plane and shear out of plane capacities of the specified anchor in concrete with characteristic compressive strength (f'_c) of 20MPa at 28 days in close to edge applications. This report summarises the results of tests conducted.

Special concrete test blocks were cast and test setups were developed. The results for the tests conducted are summarised in Table 1.

Table 1: Summary of capacities of M12×135mm Thru-Bolt stud anchors

Type of test	Mean ultimate strength (kN)	Characteristic strength (kN)	Mean concrete strength at testing (MPa)
Tension	15.9	14.6	20.7
Shear – in plane	10.8	4.6	20.7
Shear – out of plane	5.8	4.1	23.6

Contents

Executive Summary.....	i
1 Introduction	1
2 Concrete test block and Anchors	1
3 Installation of anchors	1
4 Test Setup	2
4.1 Tension test.....	2
4.2 Shear test	4
5 Test Results	7
5.1 Tension test results	7
5.2 In plane shear test results.....	9
5.3 Out of plane shear test results.....	11
6 conclusionS	12
APPENDIX A – Load displacement curves for tension tests.....	13
APPENDIX B – Load displacement curves for in plane shear tests	15
APPENDIX C – Load displacement curves for out of plane shear tests.....	18

1 INTRODUCTION

Swinburne University of Technology was commissioned by ICCONS to carry out testing of M12×135mm Thru-Bolt stud anchors (refer Figure 1) according to Clause 7.5.12.3 of NZS 3604:2011 requirements for external walls. The purpose of the tests was to assess tension, shear in plane and shear out of plane capacities of the specified anchor in concrete with characteristic compressive strength (f'_c) of 20MPa at 28 days in close to edge applications.

The scope of work included: (i) casting of test blocks measuring 2.0m × 1.4m × 0.4m with concrete having characteristic compressive strength of 20MPa at 28 days; (ii) design and fabrication of test rigs which accommodate testing of the anchors in tension, shear in plane and out of plane. (iii) conduct testing on anchors and concrete cylinder compression tests; and (vi) provide a report on the work completed.

The work was undertaken at the Smart Structures Laboratory, Swinburne University of Technology (SUT) in Hawthorn, Victoria.



Figure 1: Thru-Bolt stud anchor as provided by Icons

2 CONCRETE TEST BLOCK AND ANCHORS

Concrete was cast at Westkon Precast using standard N20 mix from Boral Concrete, $f'_c = 20\text{MPa}$, 14mm aggregate with 80mm slump.

The concrete was placed in the moulds in layers directly from the mixing truck. The concrete was vibrated to ensure appropriate compactness. Standard cylinders were also cast to confirm the compressive strength by testing.

All anchors for testing were supplied by Icons.

3 INSTALLATION OF ANCHORS

After 28 days of casting, the holes for the anchors were drilled to a depth of 75mm with a hammer drill and a brand new 12mm carbide tipped drill bit. The drill bit was checked after every 10 drills to ensure the diameter of the hard metal bit is within the tolerance specified in ETAG001. The drilled holes were cleaned as per instructions provided by ICCONS.

For all anchors, the bottom plate was 90 × 45mm MGP10 structural pine. A length of bituminous damp-proof course (DPC) was placed between the bottom plate and concrete surface for all shear tests. The bottom plate overhang was 10mm as per information supplied by ICCONS as shown in Figure 2. A 50×50mm washer was utilised in all tests. The anchors were installed to an embedment

depth of 65mm with 50mm edge distance as per installation instructions provided by ICCONS. A torque of 45Nm was applied to the anchors with a calibrated torque wrench.

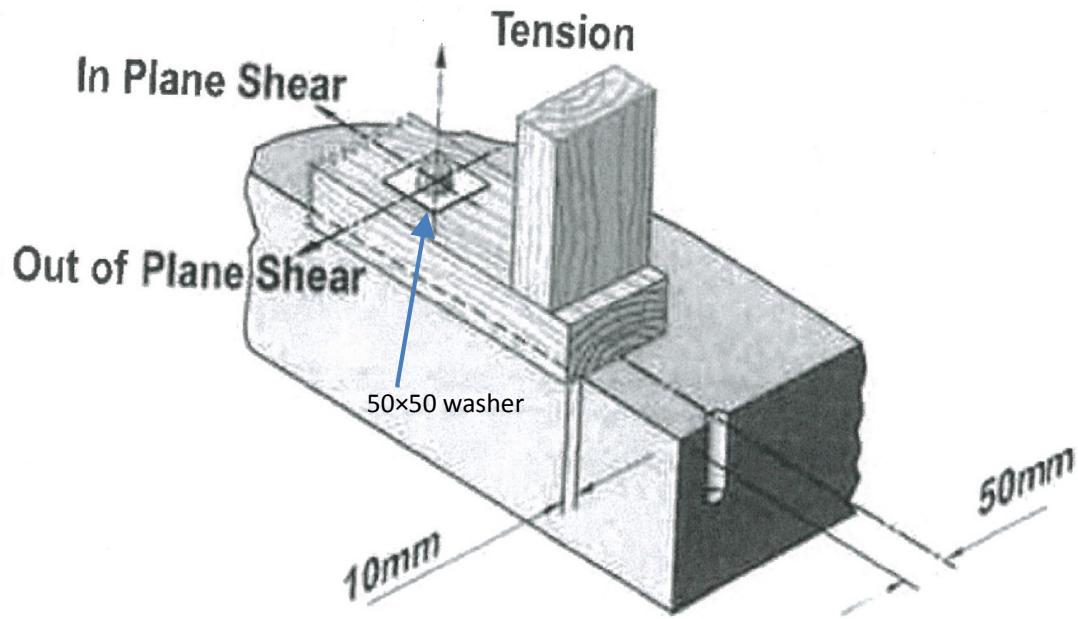

Figure 2: Installation of anchors

4 TEST SETUP

4.1 Tension test

Concrete blocks were laid side by side on the laboratory strong floor. Figure 3 shows the location of anchors for tension tests. The tension load was applied to the anchor under displacement control with a 500kN capacity closed loop hydraulic actuator with a self-reacting frame. Calibrated displacement transducers were positioned on each sides of the anchor to measure the displacement of the anchor relative to the concrete surface during loading. Refer to Figure 5 to Figure 6 for tension test setup. The measurements from the displacement transducers and the load applied from the actuator were digitally recorded during the loading. The tests were conducted by a qualified test engineer.

Loading regime for all tension tests was conducted as per BRANZ Report No. 125 (2004) supplied by ICCONS. The loading regime involved cycling three times to each of +0.25, +0.375, +0.5, +1.0, +2.0 etc. multiplied by the target load specified in NZS 3604.

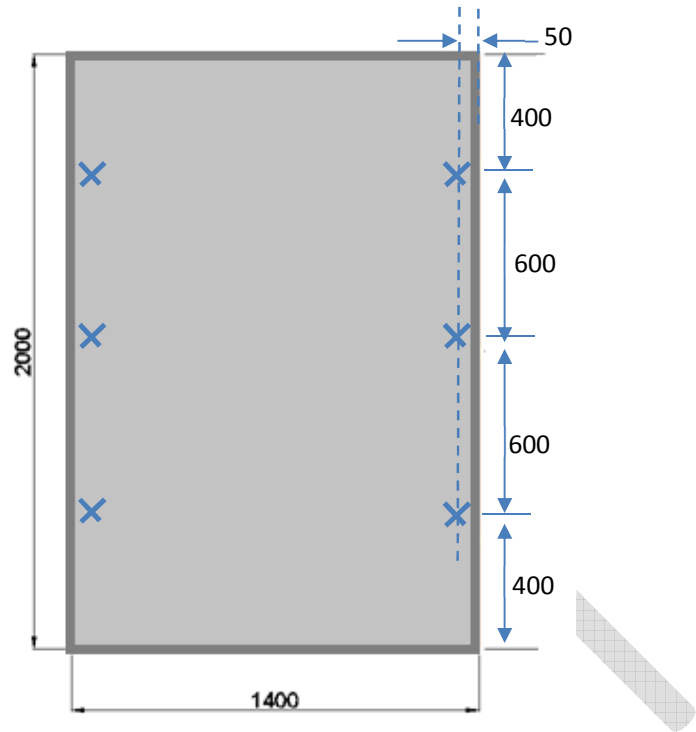

Figure 3: Schematic location of anchors for tension tests (all dimensions specified in mm), plan view

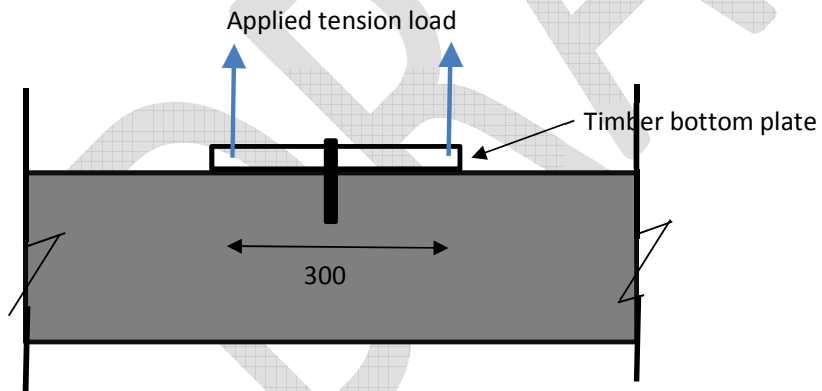

Figure 4: Schematic tension test setup

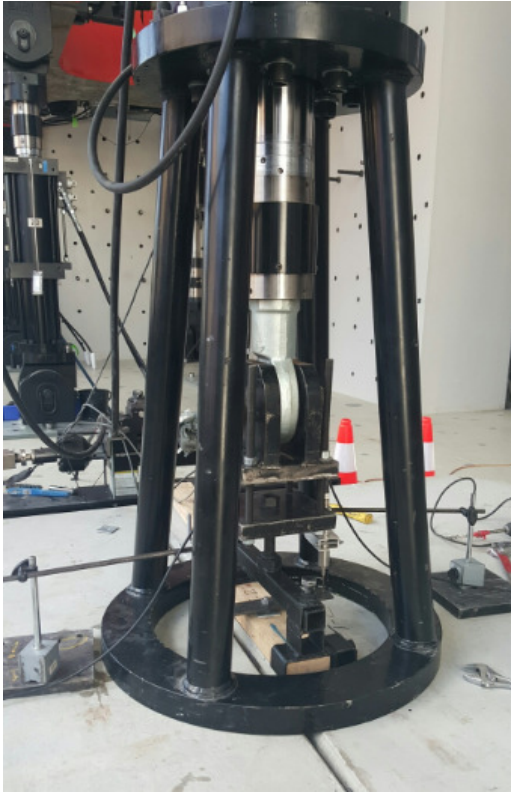

Figure 5: Test setup and instrumentations for tension test

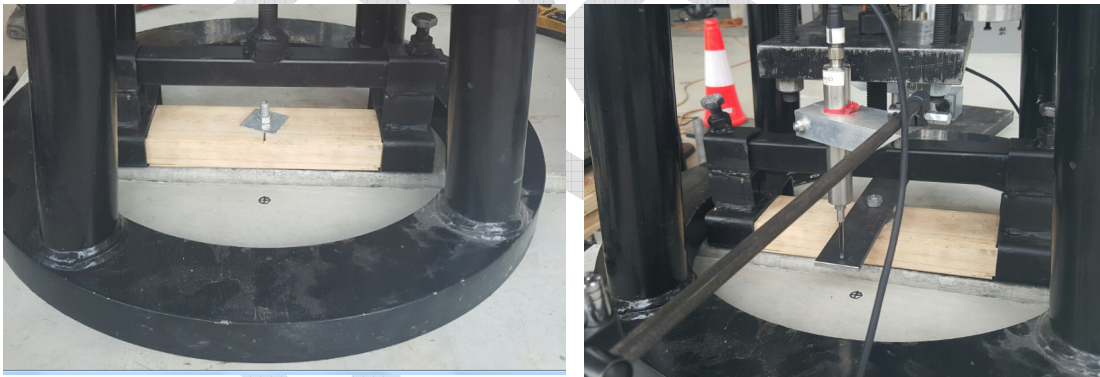

Figure 6: Close up view of test setup

4.2 Shear test

Figure 7 to Figure 3 show the location of anchors for shear tests and general test set up. The load was applied to the anchor under displacement control with a 100kN capacity closed loop hydraulic actuator. A calibrated displacement transducer was positioned to measure the displacement of the anchor relative to the concrete surface during loading. Refer to Figure 8 to Figure 10 for in plane shear test setup and Figure 11 to Figure 13 for out of plane shear test setup. The measurements from the displacement transducer and the load applied from the actuator were digitally recorded during the loading of each anchor. Tests were conducted by a qualified test engineer.

For the shear tests, the loading regime was conducted as per BRANZ Report No. 125 (2004) supplied by ICONS. The first series for each configuration was cycled three times to each of +0.25, +0.375, +0.5, +1.0, +2.0 etc. multiplied by the target load specified in NZS 3604. The remaining specimens in the series were then cycled to multiples of the displacement recorded at half the ultimate load achieved in the first specimen, as detailed in EM1.

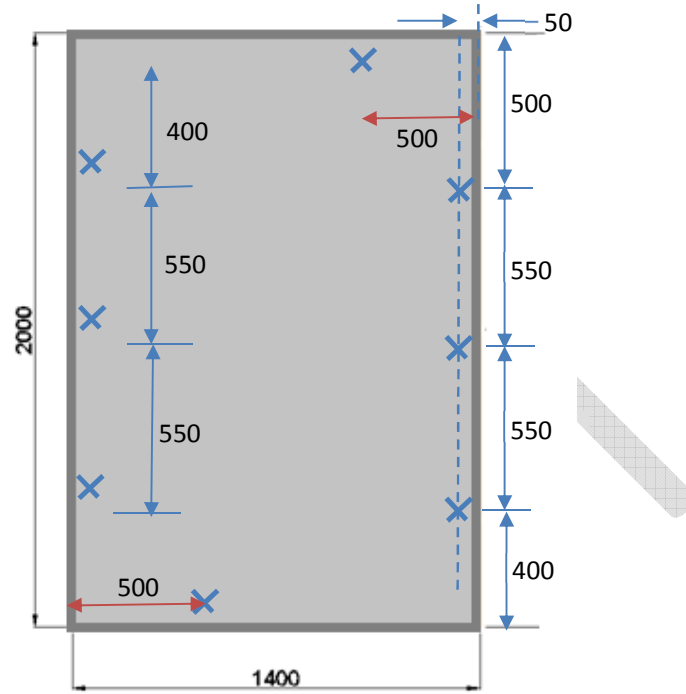

Figure 7: Schematic location of anchors for shear tests (all dimensions specified in mm), plan view

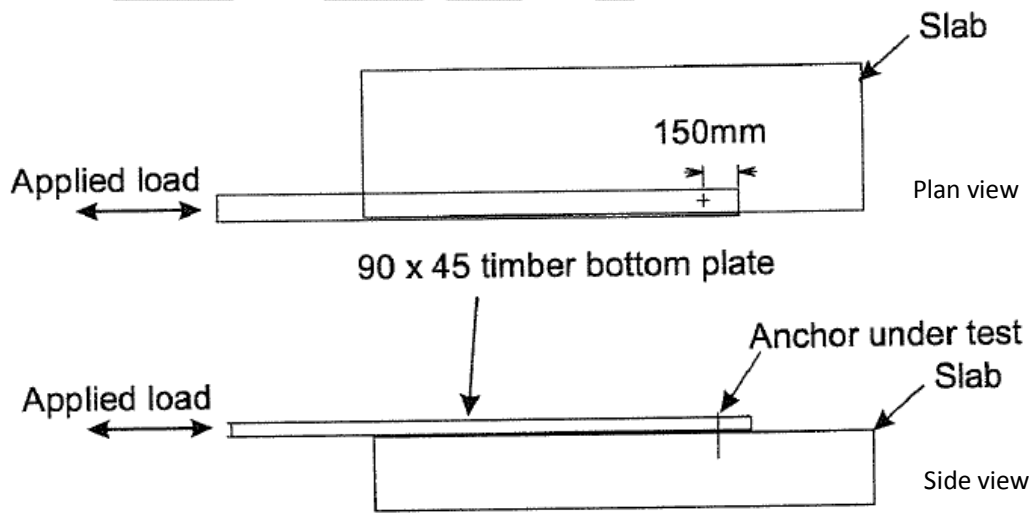

Figure 8: Schematic in plane shear test setup as per BRANZ Study Report No. 125

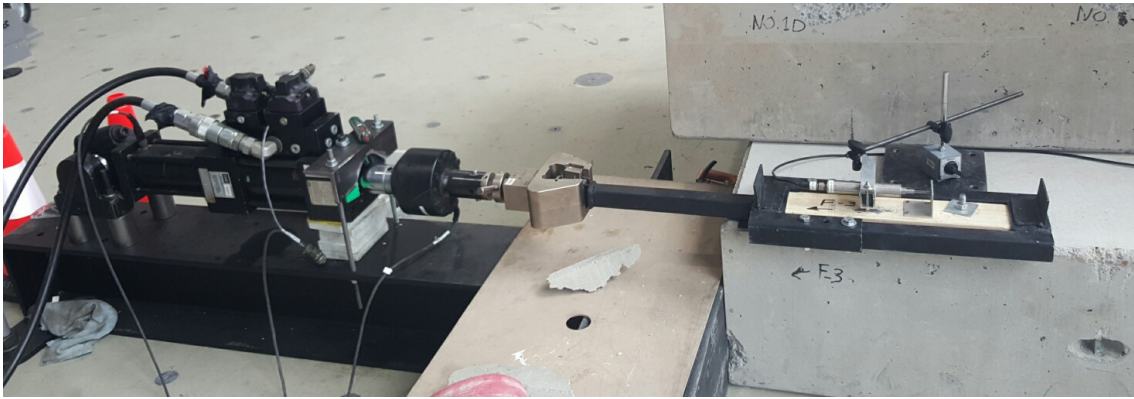

Figure 9: Shear in-plane test setup

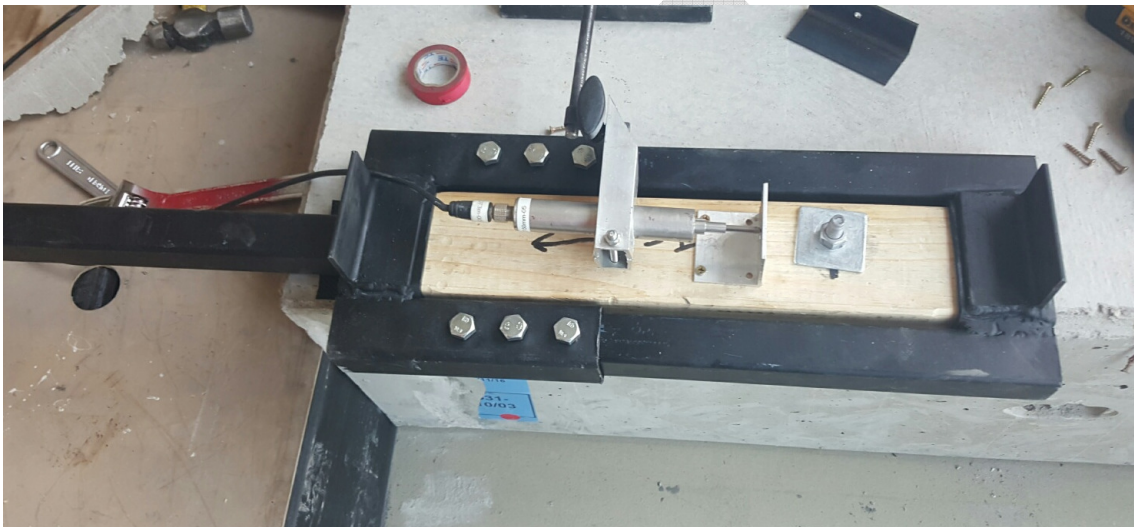

Figure 10: Shear in-plane test setup (zoomed in view)

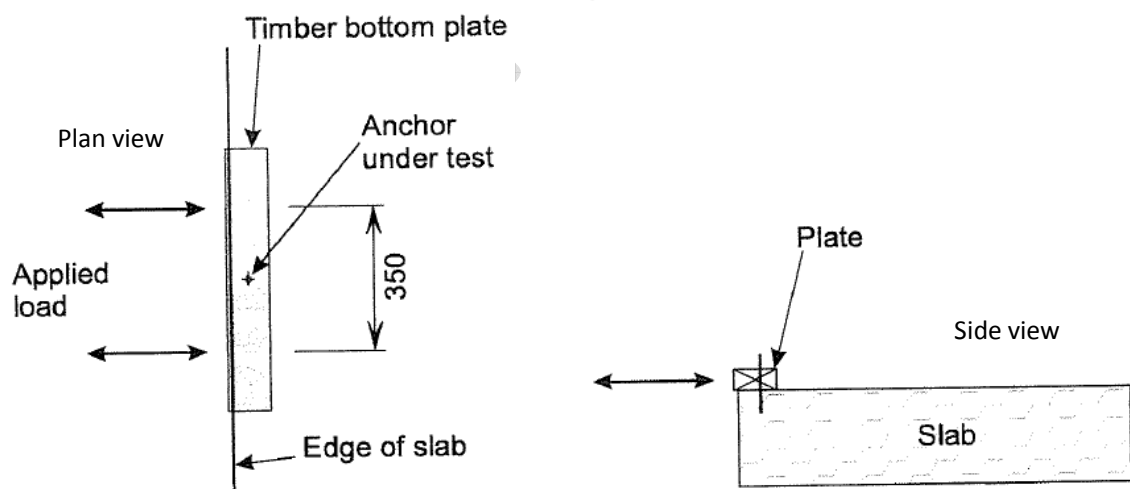

Figure 11: Schematic out of plane shear test setup as per BRANZ Study Report No. 125

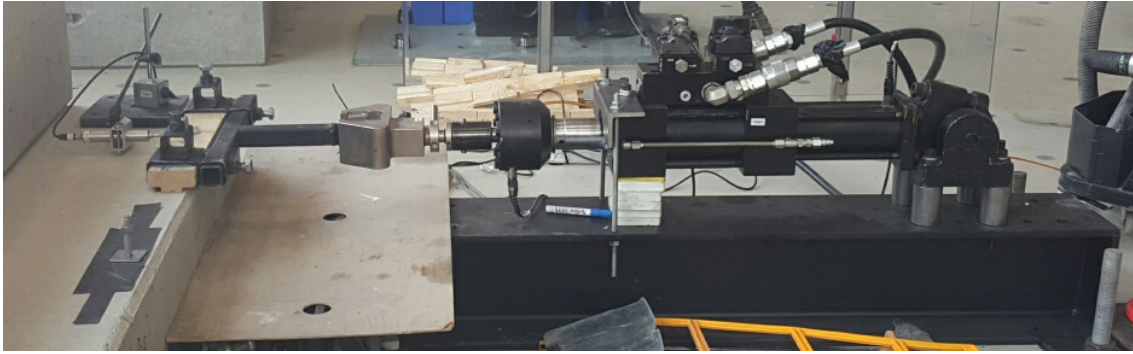

Figure 12: Shear out of plane test setup

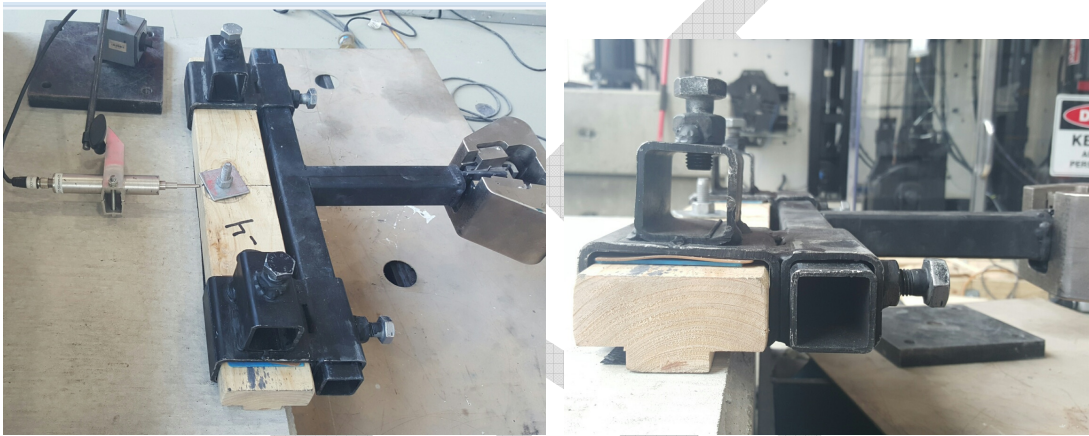

Figure 13: Close up view of the out of plane shear test setup

5 TEST RESULTS

5.1 Tension test results

Results from basic tension tests are summarised in Table 2.

Table 2: Tension test results for Thru-Bolt stud anchors

Test	Failure mode	Peak load from 3rd cycle (kN)	Maximum Ult. Load (kN)
1	Timber	14.0	15.9
2	Concrete	14.0	15.4
3	Concrete	14.0	15.8
4	Concrete	14.0	16.4
5	Concrete	14.0	15.9
Average ult. load			15.9

Average concrete cylinder strength (f_{cm}) = 20.7MPa

Number of specimens = 5

Standard deviation = 0.39 kN

Coefficient of variation = 2.4%
Sampling factor, $k_s = 3.4$
Characteristic strength = 14.6kN

Figure 14 shows the photo of bottom plate failure from the test while Figure 15 shows concrete failure from specimens. Load displacement curves from the tests can be found in Appendix A.



Figure 14: Timber failure





Figure 15: Concrete failure

5.2 In plane shear test results

Results from in plane shear tests are summarised in Table 3.

Table 3: In plane shear test results for Thru-Bolt stud anchors

Test	Peak load at 3rd cycle (+ve)	Peak load at 3rd cycle (-ve)	Failure mode	Avg. peak load from 3 rd cycle (kN)
1	14.0	14.0	Concrete	14.0
2	9.8	9.1	Anchor in shear	9.4
3	10.4	10.1	Anchor in shear	10.3
4	10.1	10.5	Anchor in shear	10.3
5	10.0	10.2	Anchor in shear	10.1
Average 3rd cycle peak load				10.8

Average concrete cylinder strength (f_{cm}) = 20.7MPa

Number of specimens = 5

Standard deviation = 1.82kN

Coefficient of variation = 16.9%

Sampling factor, k_s = 3.4

Characteristic strength = 4.6kN

Figure 16 shows the photo of concrete failure from the test while Figure 17 and Figure 18 show anchor failure from specimens. Load displacement curves from the tests can be found in Appendix B.

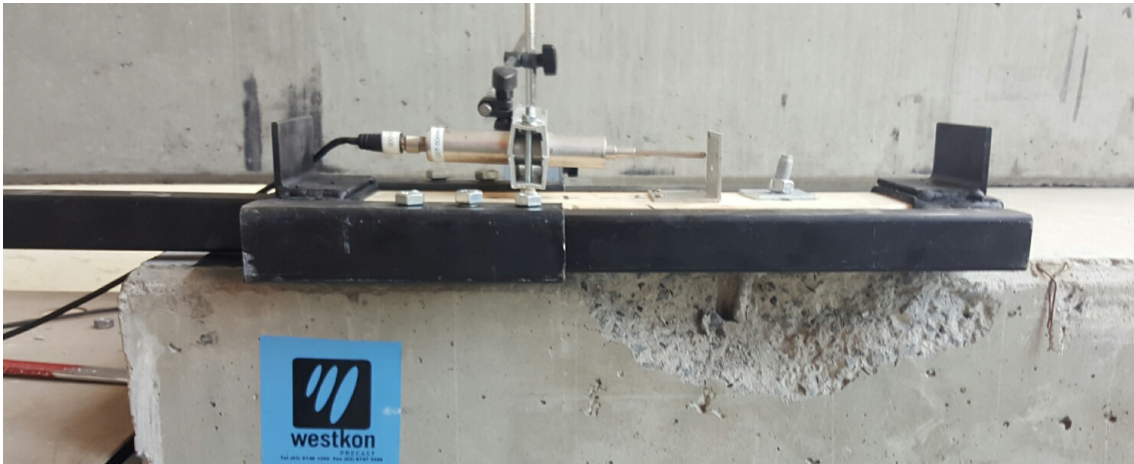

Figure 16: Concrete failure



Figure 17: Anchor in shear failure



Figure 18: Anchor in shear failure (zoomed in)

5.3 Out of plane shear test results

Results from out of plane shear tests are summarised in Table 4.

Table 4: Out of plane shear test results for Thru-Bolt stud anchors

Test	Peak load at 3rd cycle (+ve) (kN)	Peak load at 3rd cycle (-ve) (kN)	Failure mode	Avg. peak load from 3 rd cycle (kN)
1	6.0	6.0	Concrete	6.0
2	5.7	6.4	Concrete	6.1
3	5.5	6.3	Concrete	5.9
4	4.4	7.7	Concrete	6.0
5	4.1	5.7	Concrete	4.9
Average 3 rd cycle peak load				5.8

Average concrete cylinder strength (f_{cm}) = 23.6MPa

Number of specimens = 5

Standard deviation = 0.48 kN

Coefficient of variation = 8.3%

Sampling factor, k_s = 3.4

Characteristic strength = 4.1kN

Figure 19 shows typical concrete failure from specimens. Load displacement curves from the tests can be found in Appendix C.



Figure 19: Concrete failure

6 CONCLUSIONS

Experimental test setups were developed to test Thru-Bolt stud anchors in tension, shear – in plane and out of plane. The anchors were installed in drilled holes of 12mm in diameter and hole depth of 75mm with embedment depth of 65mm, at 50mm to concrete edge with 90x45 MGP10 structural pine as bottom plate. The stud anchors were tightened with a torque of 45Nm. Installation of anchors was done in accordance to instructions provided by ICCONS.

Table 5 summarises the results for the Thru-Bolt stud anchors

Table 5: Summary of results for Thru-Bolt stud anchors

Type of test	# of samples	COV	Average peak load from 3 rd cycle (kN)	Characteristic strength (kN)	Mean concrete strength at testing (MPa)
Tension	5	2.4%	15.9	14.6	20.7
Shear – in plane	5	16.9%	10.8	4.6	20.7
Shear – out of plane	5	8.3%	5.8	4.1	23.6

APPENDIX A – LOAD DISPLACEMENT CURVES FOR TENSION TESTS

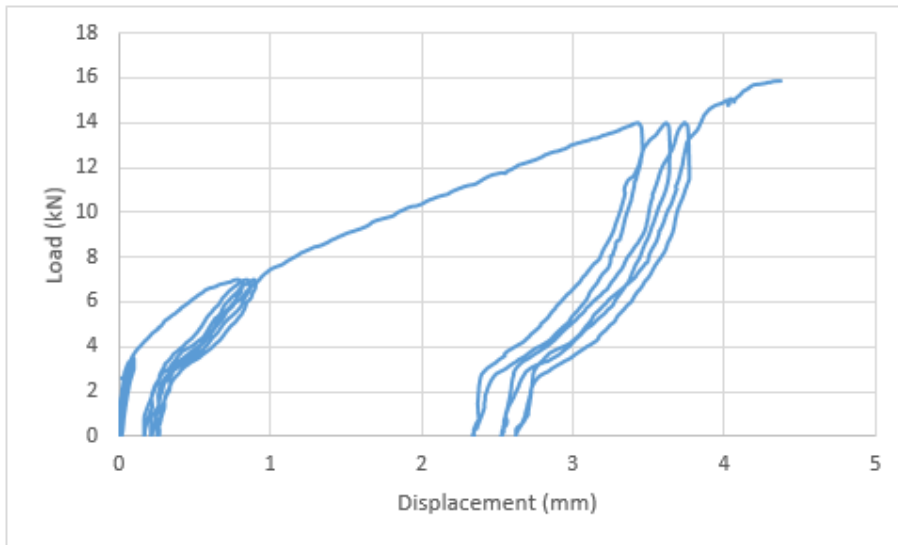

Figure 20: Load displacement curve for tension test #1 for Thru-Bolt stud anchor

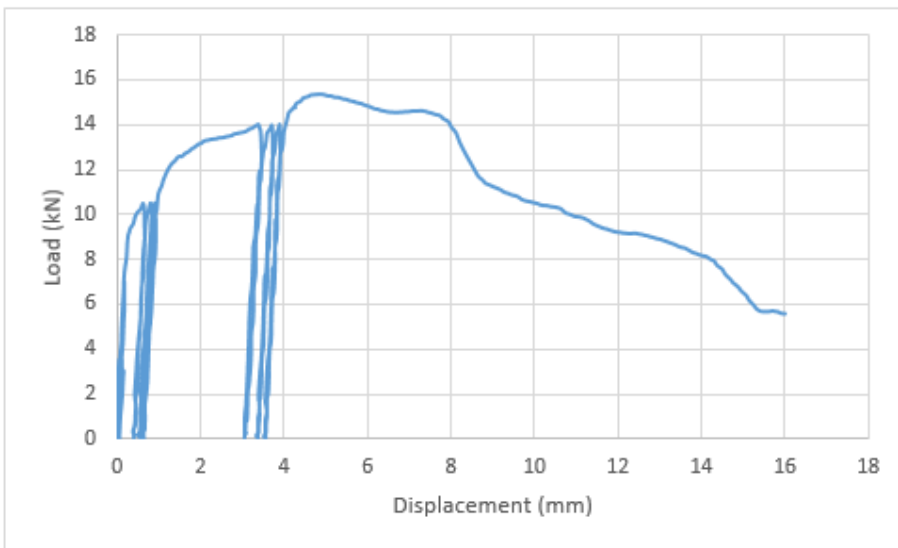

Figure 21: Load displacement curve for tension test #2

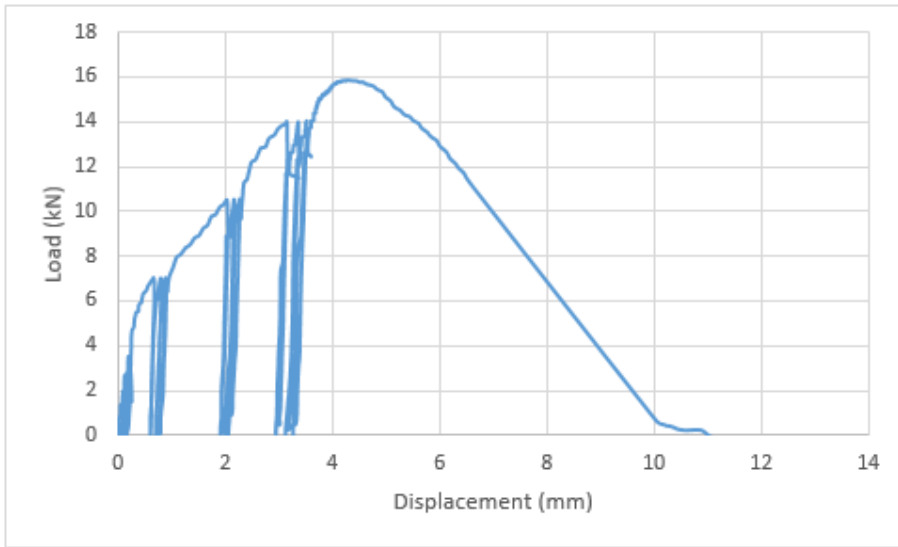

Figure 22: Load displacement curve for tension test #3

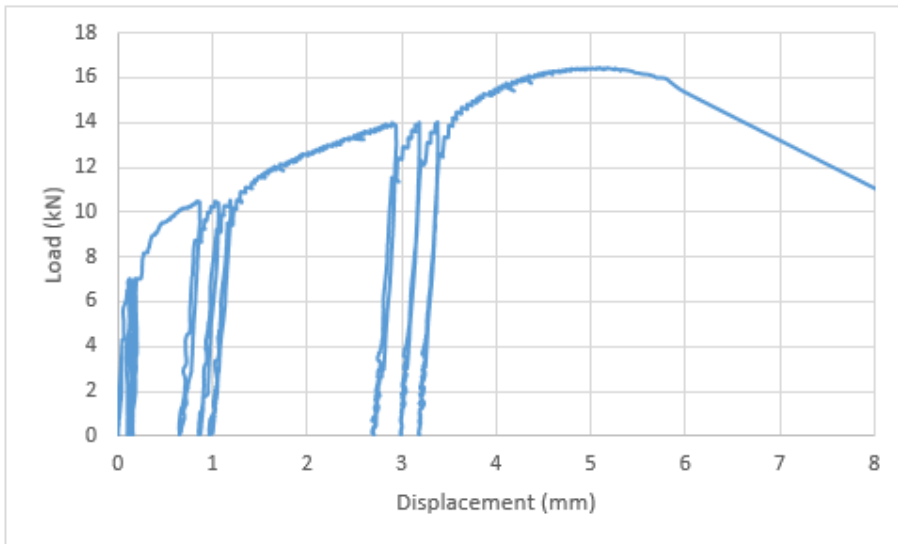

Figure 23: Load displacement curve for tension test #4

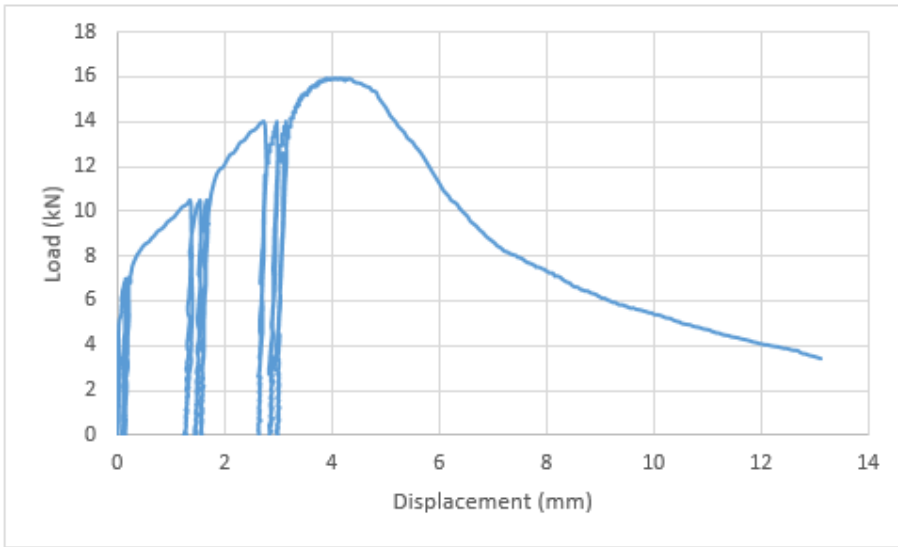

Figure 24: Load displacement curve for tension test #5

APPENDIX B – LOAD DISPLACEMENT CURVES FOR IN PLANE SHEAR TESTS

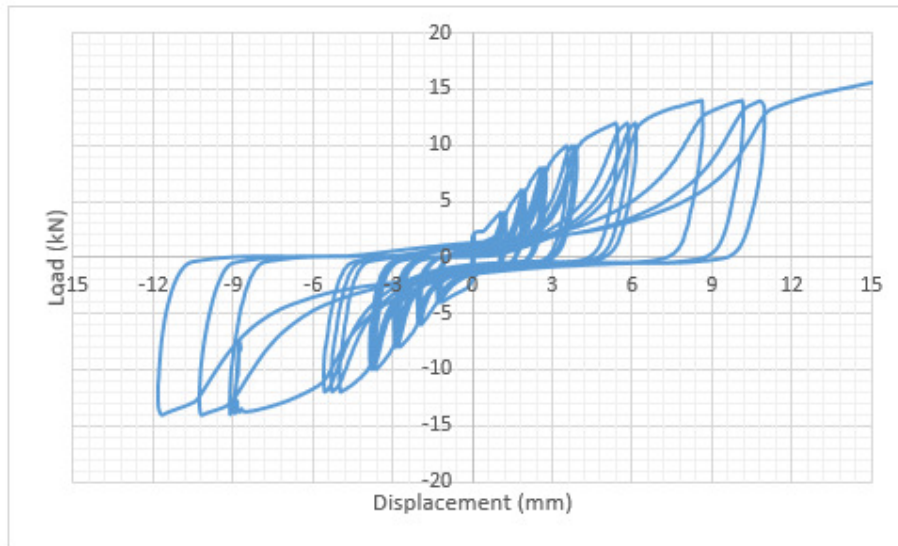

Figure 25: Load displacement curve for in plane shear test #1 for Thru-Bolt stud anchor

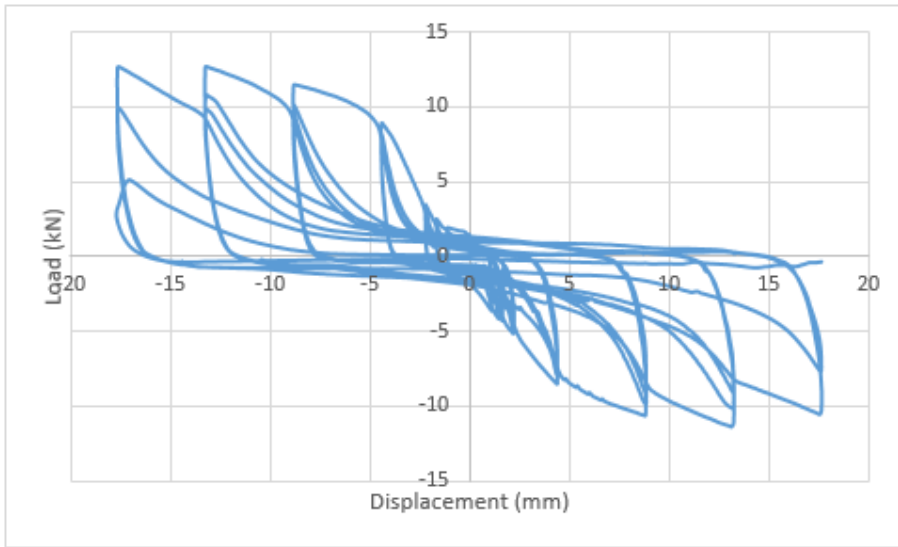

Figure 26: Load displacement curve for in plane shear test #2

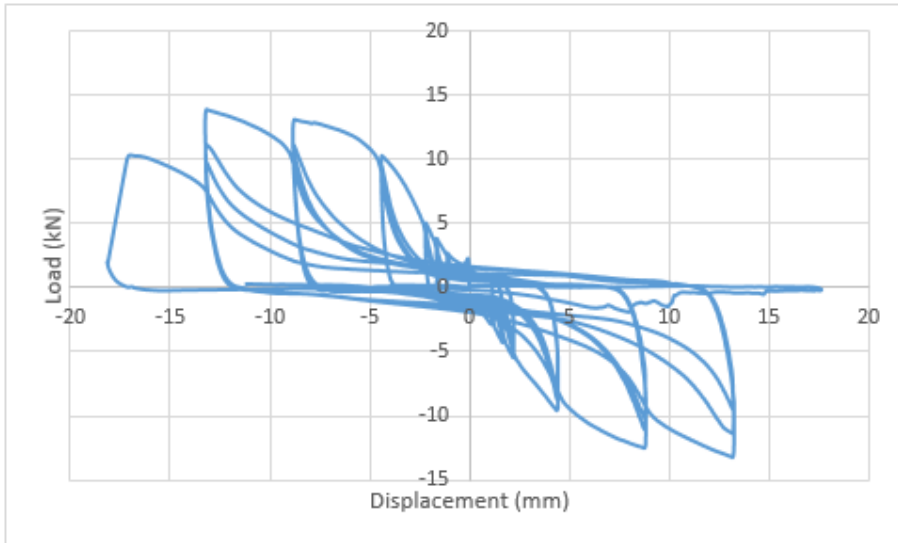

Figure 27: Load displacement curve for in plane shear test #3

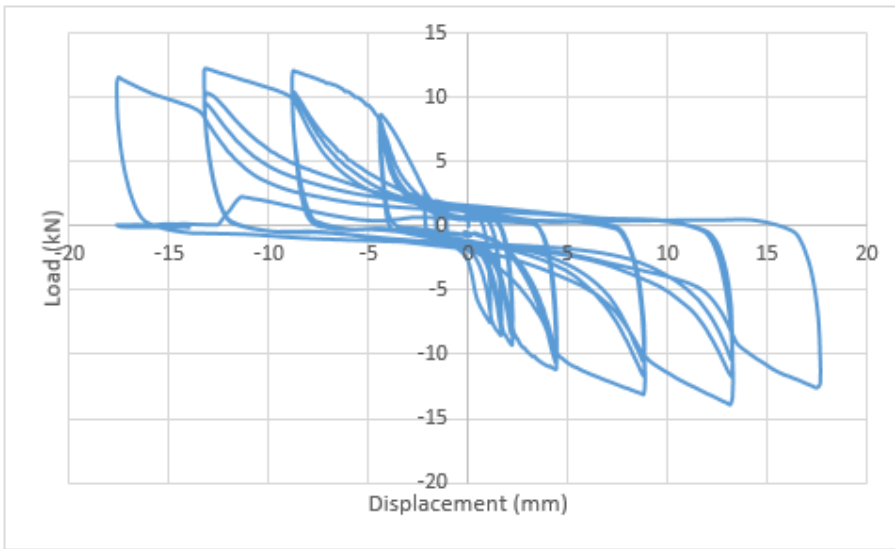

Figure 28: Load displacement curve for in plane shear test #4

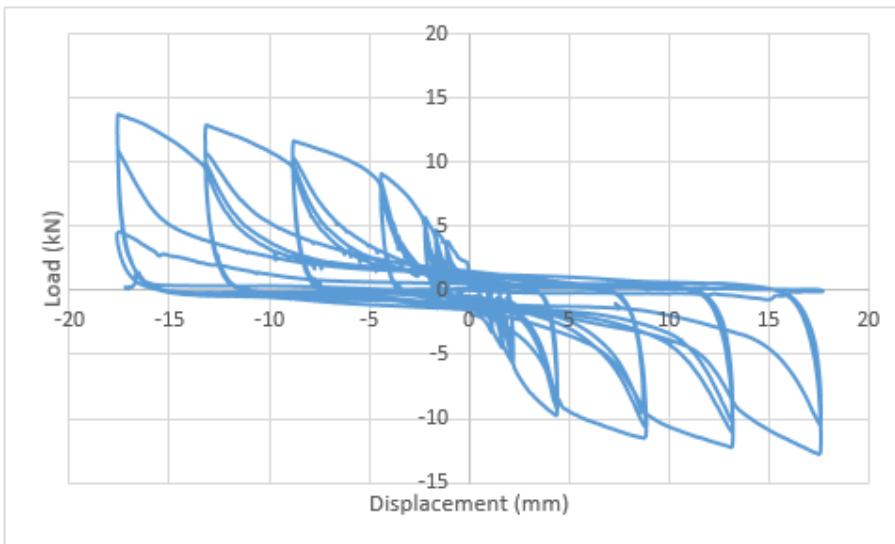

Figure 29: Load displacement curve for in plane shear test #5

APPENDIX C – LOAD DISPLACEMENT CURVES FOR OUT OF PLANE SHEAR TESTS

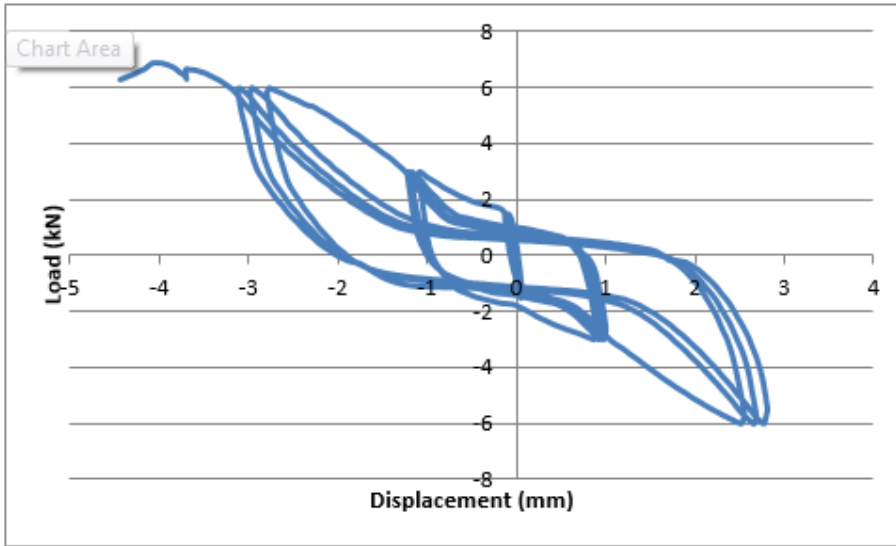

Figure 30: Load displacement curve for out of plane shear test #1 for Thru-Bolt stud anchor

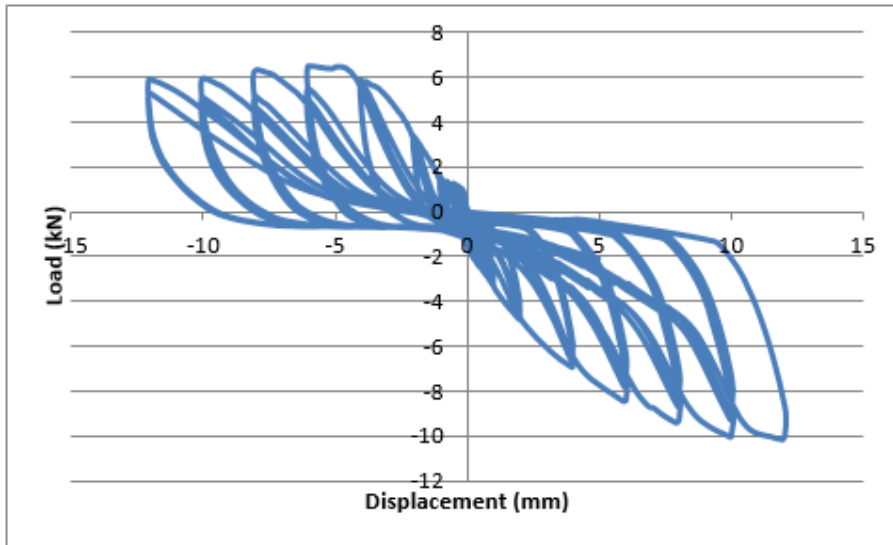

Figure 31: Load displacement curve for out of plane shear test #2

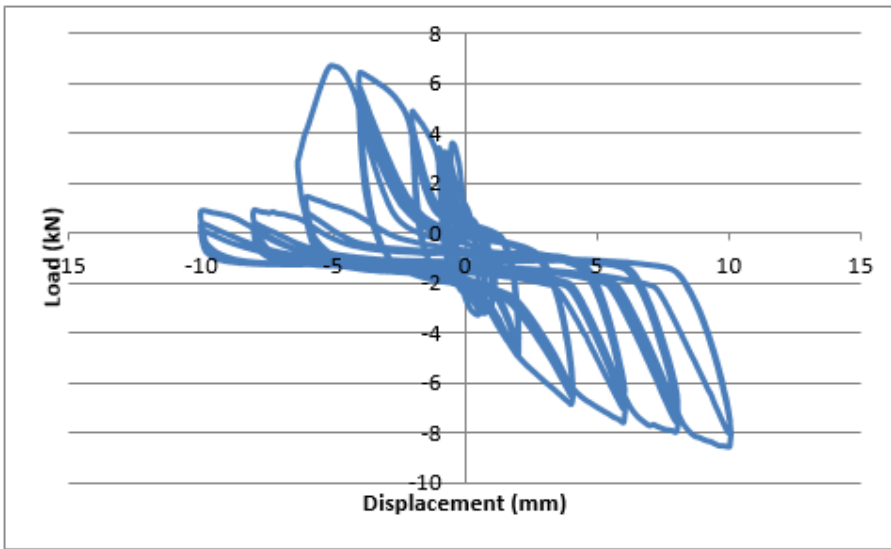

Figure 32: Load displacement curve for out of plane shear test #3

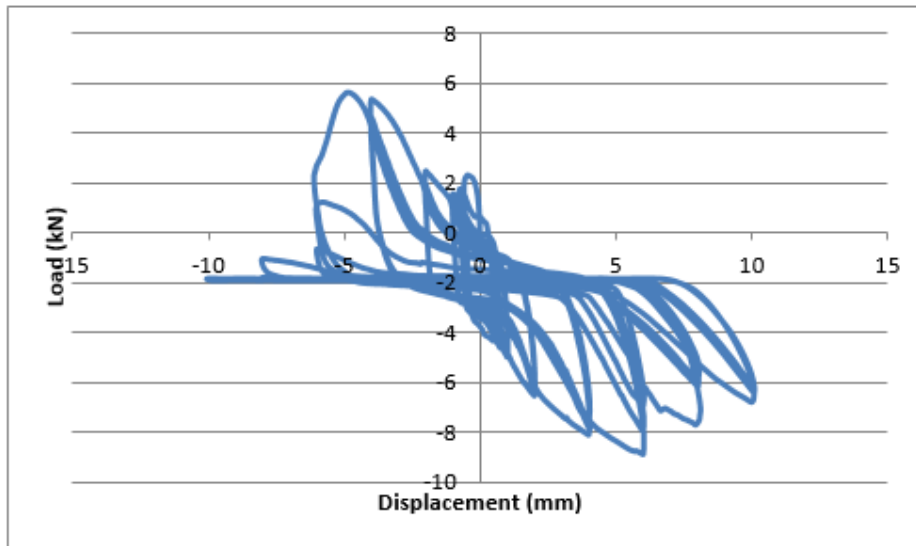

Figure 33: Load displacement curve for out of plane shear test #4

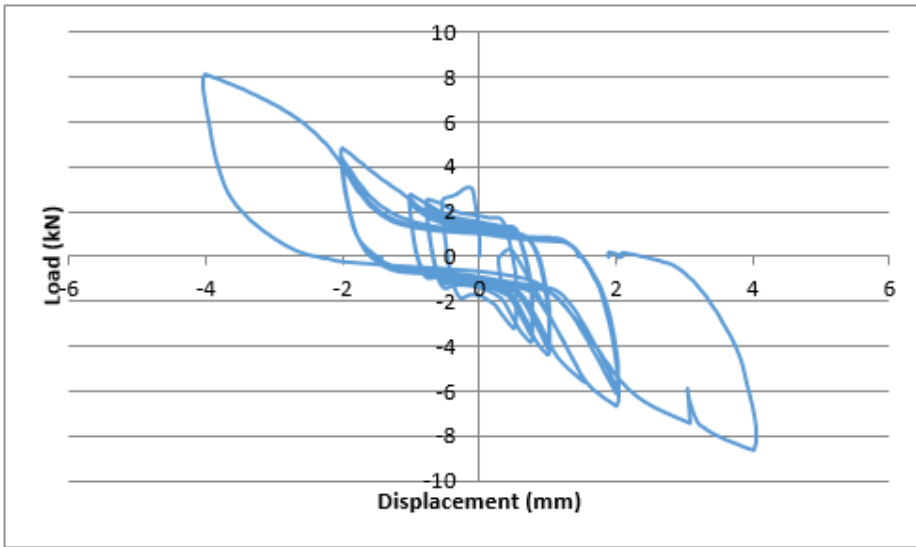

Figure 34: Load displacement curve for out of plane shear test #5

DRAFT