

For doors that < slide > inside walls

## HowTO install this TimberFormed® Single sliding door unit



Before you start:

### READ this HowTO (Installation Instructions) CAREFULLY!

(It could save you  
lots of work!)

Other CS Cavity Sliders fitted with timber jambs are covered by this HowTO. They are:

EasyOpen® WC	(EO)	
MidWay®	(MW)	
Serveries™	(SERV)	
SofStop®	(SF)*	
SoundStop®	(SS)*	* Extra data sheets may be required for these units.
System50Kit®	(S50)*	

Check out the full range of products and use our online calculator at: [www.csfordoors.co.nz](http://www.csfordoors.co.nz)

**Keep this HowTO handy.  
You may need it later on.**

Another quality product from:



## WHAT YOU NEED TO KNOW FIRST.

### Construction of the wall.

The wall referred to in these instructions is ex 100mm x 50mm wooden framework. In reality this may mean a 94mm x 47mm or 90mm x 45mm wooden framework.

Although not shown, the unit covered in this HowTO may also be fitted into other types of wall materials (steelstud, concrete, brick, etc.).

For concrete or masonry type walls:

fix ex 100mm x 50mm timber fixing plates into the opening on both sides and under the head.

Fix these in place with ø10mm x 98mm long countersunk masonry anchors at 400mm centres.

### Lintel or trimmer sizes.

CS CavitySliders are non-loadbearing units. They require the lintel (or trimmer, ceiling joist or structural component) directly above the track to span the full trim size opening width. Timber lintels sized from NZS3604 are acceptable if the weight of the door leaf/leaves is less than 75kg/m total door width. If heavier, specific design is required for all other kinds of structural components and for the timber lintels.

### The hole in the wall.

Calculation of how big the hole in the wall framing should be to fit in this unit:

**CS TimberFormed Single unit**

**Height** = door leaf height + 95mm  
(also for EO, MW, SERV, SS, S50)

**Height** = door leaf height + 105mm (SOFSTOP only)

**Width** = (door leaf width x 2) + 30mm  
(also for MW, SERV, SF, SS, S50)

**Width** = (door leaf width x 2) - 70mm (for EO only)

### Standard clearances under the door.

With this CS TimberFormed unit sitting hard on top of the concrete or timber floor, the clearance under the door leaf ranges between 22 - 30mm (adjustable). The majority of these standard clearances is taken up by the floor covering (e.g. carpet, tiles etc.).

### Modified clearances under the door.

If you require **more** than 30mm clearance under the door: pack the unit off the floor by the extra amount you need.

If you need **less** than 22mm clearance under the door leaf (e.g. for polished timber floors) there are three options to do this:

- A CS FOR DOORS can supply special seals that can be fitted to the bottom of the door leaf.
- B\* A door leaf up to 15mm taller can be fitted.
- C\* The whole cavity can be made up to 15mm shorter.  
(\*B & C are only available when pre-ordered.)

### Contamination of the top track.

Never drill, nail or screw through the centre section of the track. Make sure no dirt, grit or aluminium swarf gets into the track. This could impair the smooth running of the carriages.

### Fixing cavity slider to the floor

Installing the cavity slider 100% plumb and level will **NOT** guarantee a correctly sliding door. If any of the wall, lintel, floor and door are not plumb and straight this can cause the door to slide incorrectly into the pocket. It is for this reason that the skirting block fixing (found at the base of the cavity slider behind the split jambs) is only secured once you have ensured door is running parallel to the cavity pocket.

Go to page **3** (overleaf) →

## NOW FOR THE INSTALLATION.

### 1 Remove packaging and check components.

Lay the CS TimberFormed unit flat on the ground in front of the door opening.

Remove the transportation cleat (if still fitted) from the bottom plate assembly. (Take out the two screws and the three staples.)

Check for any obvious product defects.

Lay the unit on its back and sight the gap to check for normal clearances (drawing T).

If anything looks out of specification or you are unsure, contact CS before beginning your install.

### 2 Fit the door leaf (if not already fitted).

Refer to 'Fitting your own door', instruction 15, overleaf).

### 3 Fit the closing jamb to the unit (drawing W).

Use 2 screws 8 gauge x 25mm long, as supplied (drawing W). For NoClosingJamb (NCJ) detail option ignore this (refer to the Additional HowTO Information sheet).

### 4 Place the whole unit into the framed opening in the wall.

Check that the jack studs on both sides of the door opening are plumb in both directions.

### 5 Fix the aluminium back stud.

Plumb-up the two timber split jambs (drawing U). Use a level!

While keeping the timber split jambs plumb, pack behind the aluminium back stud as shown. Screw the aluminium back stud including the packing to the 100mm x 50mm jack stud through the pre-punched holes.

**Timber studs:** use 8 gauge x 29mm wood screws.

**Steel studs:** 8 gauge x 29mm self-tapping screws. (For NCJ detail option the track should butt into the finished wall lining. Refer to the Additional HowTO Information sheet).

### 6 Level the track (drawing W).

The track must be fitted level and straight.

**Do not** pack above the track.

The track for all units with doors over 910mm wide must be fixed to the lintel at 600mm centres through the aluminium flanges on both sides of the track.

Fit the first screws 50mm back from the closing jamb end of the track.

Counter bore the timber pelmet blocks (drawing W) so that the screw heads pull hard up under the aluminium flanges.

For **timber** lintels: Use 8 gauge screws penetrating the lintel by at least 25mm.

For **light steel** lintels (under 2mm wall thickness): Use 8 gauge self-tapping screws which penetrate the lintel by at least 5mm.

For **heavy steel** lintels: Use M5 machine bolts and nuts.

For **Full-Height** (FH) detail option: The bottom of the track should finish flush with the underside of the finished ceiling (refer to the Additional HowTO Information sheet).

### 7 Fix the closing jamb (if required)(drawing U).

Plumb closing jamb. Use a level!

Pack and nail at 500mm centres to the jack stud through the recessed centre section of the closing jamb and packing.

### 7 First: fix the top of the closing jamb (drawing U). Second: fix the bottom of the closing jamb.

For **timber**: use  $\varnothing$ 2.8mm x 60mm nails.

For **steel**: use 8 gauge self tapping screws.

Ensure that the distances between the closing jamb and the split jamb are the same.

**The distance at the bottom must never be more than the distance at the top.** Measure this carefully! Fix between the top and bottom.

Use a level to make sure that the closing jamb is straight and plumb.

### 8 Fix the bottom plate assembly (drawing X).

The door must slide parallel with the bottom plate assembly (see the 2 sets of black A-A arrows). If not, gently tap the front of the assembly to the left or right until it does.

The door should now slide smoothly and fit into the recess in the closing jamb, leaving parallel gaps on either side between the door leaf and the closing jamb.

Fix the skirting block fixing to the floor only when the cavity pocket has been adjusted so that the **door closes neatly into the closing jamb and slides parallel to the bottom plate of the cavity slider**. Fix the bottom plate assembly to the floor as follows:

#### ▮ To **concrete** floors:

Fix with  $\varnothing$ 8mm x 90mm masonry anchors through the pre-drilled holes in the skirting fixing blocks of the bottom plate. (See the red stamped arrow on the timber).

#### ▮ To **timber** floors:

Fix the bottom plate assembly with  $\varnothing$ 3.15mm x 75mm nails on either side in the centre of the skirting fixing block thickness. (See the red stamped  $\oplus$  on the timber). Pre-drill  $\varnothing$ 3mm holes for these nails.

### 9 Adjust the door height (drawing V).

Use the small end of the spanner supplied to rotate the hexagonal nut at the bottom of the carriage hanger shaft. Adjust the doors for plumb.

To **raise** door: Rotate spanner from **left to right**.  
To **lower** door: Rotate spanner from **right to left**.

Note: The top of the hanger shaft screws into a self-locking nut. If the hexagonal nut is turned downwards too far, the shaft will become loose from the self-locking nut. If the turning resistance suddenly feels much easier, you have gone too far.

### 10 Fit the head jambs (drawing W)

(if not already fitted). Before fitting head jambs, check that you have the desired clearance under the door and that the door is plumb (instruction 9). Slide the head jamb into place between the vertical jambs. When installing a unit with NCJ detail, scribe to suit the distance between the split jamb and opposing wall. (Refer to the Additional HowTO Information sheet.)

'Flush up' the joints, then screw them into place with the 8 gauge x 32mm long countersunk head screws (as supplied). Gently tap wooden plugs to cover the screw heads.

For Serveries units (SERV) the sill (not included unless asked for) should not be thicker than 25mm and fit neatly between the vertical jambs.

## FINISHING THE INSTALLATION.

Go to page **4** (overleaf) 

# T JAMB CLEARANCE

See points 1 and 11.

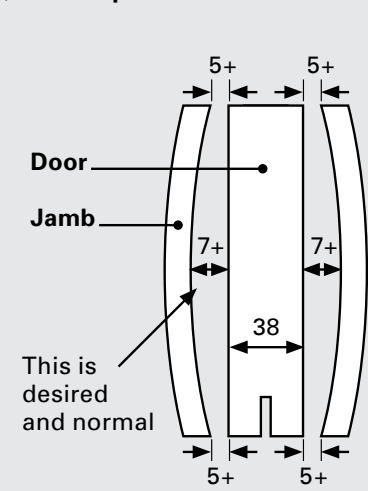

Jamb spreader

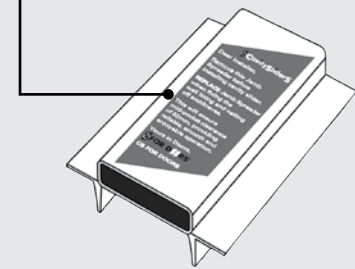

# U ELEVATION

See points 5 and 7.

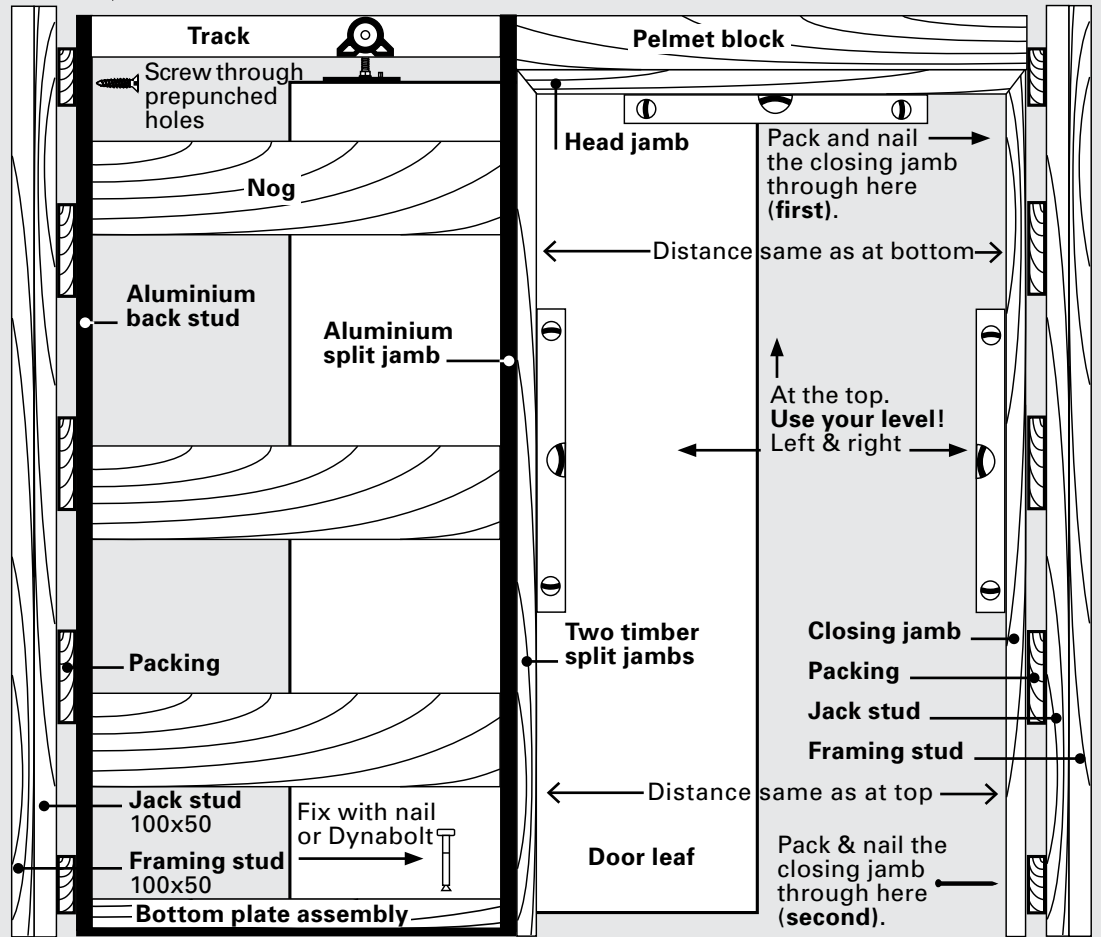

# V ADJUSTING & REMOVING CarriSnap™ CARRIAGES

See points 9, 14 & 16.

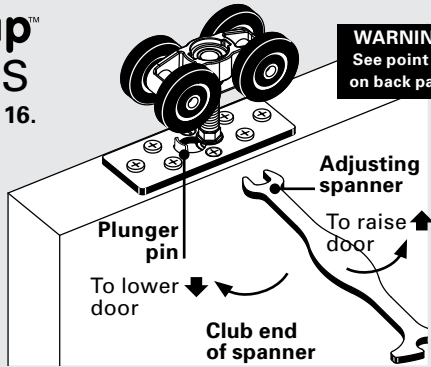
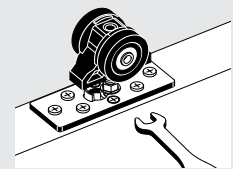

# X BOTTOM PLATE ASSEMBLY

See points 8, 13 and 14.

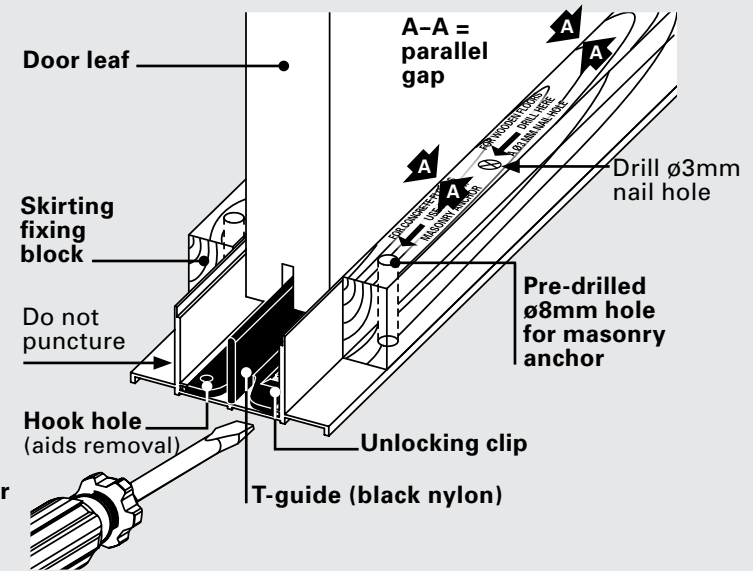

# W TRACK CROSS SECTION

See points 3, 6, 10, 12 and 16.

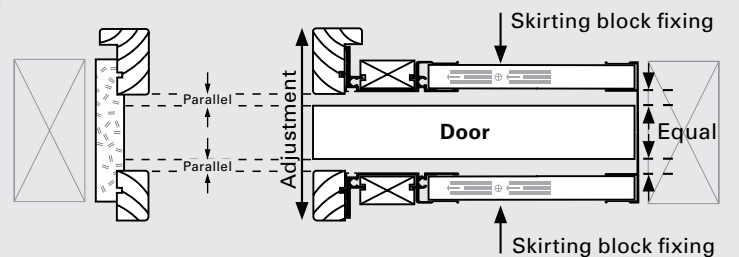
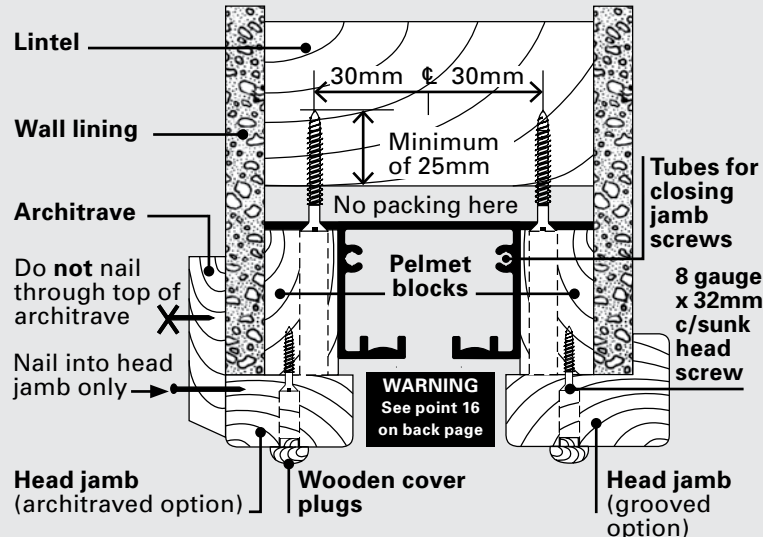

**11 Fixing the wall linings** (drawing T).

The cavity slider comes with split jambs intentionally 'rounded out' as shown (drawing T). This round out is to accommodate any slight bowing of the door leaf and to allow door hardware to clear the jambs.

The supplied 'jamb spreader' should be inserted into the cavity slider opening prior to fixing wall linings and architraves.

Wherever possible, linings should only be glued on. Use short drywall screws to hold linings in place until glue is dry. For 10mm linings use maximum 25mm long drywall screws.

We recommend sealing the inside of all plasterboard linings and mdf architraves.

**12 If fitting architraves** (drawing W).

Nail the architraves to the four vertical jambs and the two horizontal head jambs.

Use panel pins with a maximum length of 25mm plus the thickness of the architrave.

Nail the back of the architrave to the split jamb blocks using panel pins with a maximum length of the combined thicknesses of the architrave and wall linings plus 15mm.

Note: Nail the horizontal architraves to the head jambs; however do not nail them to the timber pelmet blocks above the head jamb.

**13 If fitting skirtings** (drawing X).

When you fix the skirtings, make sure that you do **not** puncture the aluminium extrusion of the bottom plate assembly. The maximum length of the panel pins are the combined thicknesses of the skirting and the wall lining **plus** 17mm.

**Do not hammer too hard against the bottom plate. This may damage the channel through which the door leaf slides.**

**14 Removing the door leaf** (drawing X, V, Y).

Begin by removing the head jamb from one side (if fitted).

Fit the club end of the adjusting spanner over the hexagonal nut at the bottom of the hanger pin (drawing V).

Use the extended part of the spanner to press down the plunger pin that protrudes up from the mounting plate. Once this plunger is fully depressed, slide the spanner sideways towards the plunger pin.

The whole carriage (including the shaft) will now disengage from the mounting plate.

It is not always easy to slide the spanner sideways. You may need to relieve the door's weight by putting a wedge between door and floor.

If you need to remove the T-guide: lift the unlocking clip (drawing X) and pull the black nylon T-guide forward. Use a hook to aid removal if required.

To remove the carriages: Slide them out of the notched end of the track.

**15 Fitting your own door** (drawing Z).

a) At the bottom of the door leaf cut a groove to the dimension and tolerance shown (drawing Z). Make it central to the door thickness and absolutely straight.

b) Drill mounting plate holes to the correct size and depth as marked (drawing Z).

c) Fix both mounting plates to the door. Make sure they are placed exactly in the centre of the door thickness. **Go to page 5** →

d) Load the carriages through the notched end of the track.

e) Position the door underneath the carriages. Raise the door up so that the round head of the wheel hanger shaft lines up with the keyhole shaped hole in the mounting plate (drawing Z).

f) Depress the plunger using the wheel hanger shaft head and slide sideways until it snaps into locked position. Repeat for the other carriage.

**16 WARNING** (drawing V and W).

**CS Cavity Sliders require the track running surface to be clean and free of any contamination or damage. For smooth reliable service, the tyres on the carriage should not be chipped, dented or have swarf embedded in the tyre.**

Please ensure you take extra care with the carriages to avoid any damage during the installation process.

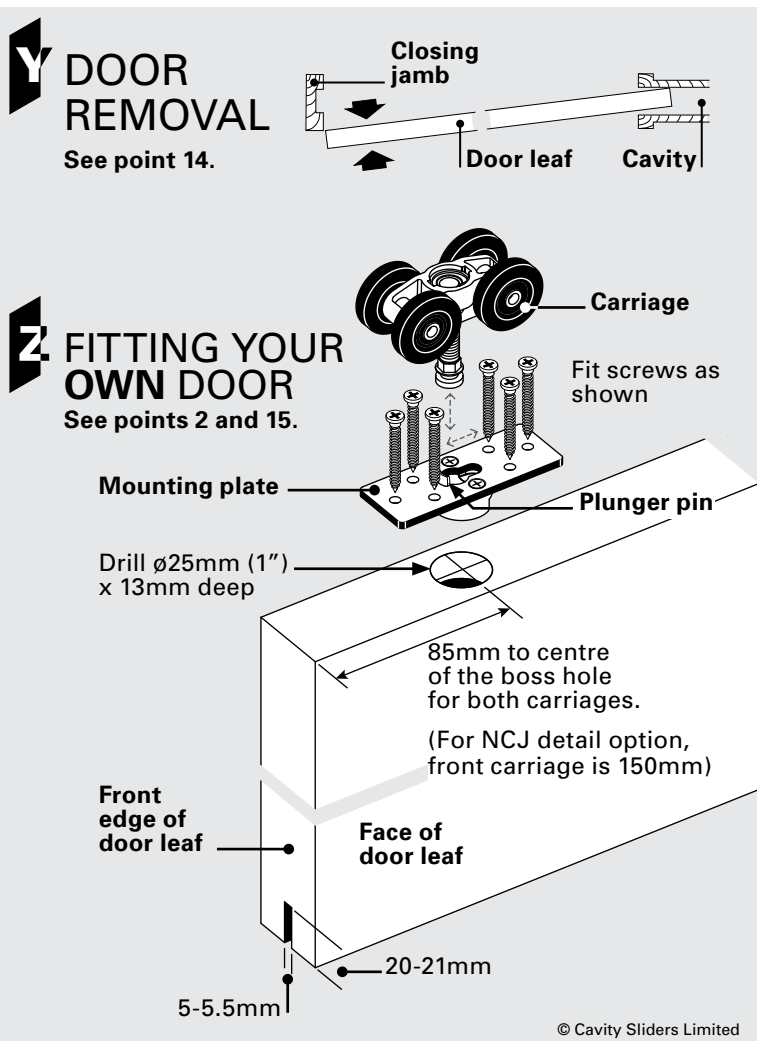

**Cavity Sliders Limited  
Auckland Head Office**

5 - 7 Rakino Way  
Mt Wellington  
PO Box 112349, Penrose  
Auckland 1642, NZ  
T 09 276 0800  
F 09 276 2525



info@csforddoors.co.nz  
www.csforddoors.co.nz



For doors that <slide> inside walls

All copyright and other property in this document is reserved by Cavity Sliders Limited. Details and specifications are subject to change without notice. Whilst all care is taken to ensure the accuracy of all information, no responsibility will be accepted for any errors or omissions. \*Guarantee conditions apply. Contact CS FOR DOORS for details  
© CS FOR DOORS, CS CAVITY SLIDERS and CS TIMBERFORMED are Registered Trademarks. New Zealand Patent No: 533838.

For doors that < slide > inside walls

## HowTO install this TimberFormed® Bi-Parting sliding door unit



Before you start:

### READ this HowTO(Installation Instructions) CAREFULLY!

(It could save you  
lots of work!)

Other CS Cavity Sliders fitted with timber jambs are covered by this HowTO. They are:

EasyOpen® WC	(EO)	
MidWay®	(MW)	
Serveries™	(SERV)	
SofStop®	(SF)*	* Extra data sheets may be required for these units.
SoundStop	(SS)*	
System50Kit®	(S50)*	

Check out the full range of products and use our online calculator at: [www.csfordoors.co.nz](http://www.csfordoors.co.nz)

Keep this HowTO handy. You may need it later on.

Another quality product from:



### WHAT YOU NEED TO KNOW FIRST.

#### 1 Construction of the wall.

The wall referred to in these instructions is ex 100mm x 50mm wooden framework. In reality this may mean a 94mm x 47mm or 90mm x 45mm wooden framework.

Although not shown, the unit covered in this HowTO may also be fitted into other types of wall materials (steelstud, concrete, brick, etc.).

For concrete or masonry type walls:

fix ex 100mm x 50mm timber fixing plates into the opening on both sides and under the head.

Fix these in place with ø10mm x 98mm long countersunk masonry anchors at 400mm centres.

#### 1 Lintel or trimmer sizes.

CS Cavity Sliders are non-loadbearing units. They require the lintel (or trimmer, ceiling joist or structural component) directly above the track to span the full trim size opening width. Timber lintels sized from NZS3604 are acceptable if the weight of the door leaf/leaves is less than 75kg/m total door width. If heavier, specific design is required for all other kinds of structural components and for the timber lintels.

#### 1 The hole in the wall.

Calculation of how big the hole in the wall framing should be to fit in this unit:

**CS TimberFormed Bi-Parting unit**

**Height** = door leaf height + 95mm  
(Also for EO, MW, SERV, SS, S50)

**Height** = door leaf height + 105mm (for SOFSTOP only)

**Width** = (door leaf width x 4) + 10mm

(Also for MW, SERV, SF, SS, S50)

**Width** = (door leaf width x 4) - 190mm (for EO only)

#### 1 Standard clearance under the door.

With this CS TimberFormed unit sitting hard on top of the concrete or timber floor, the clearance under the door leaf ranges between 22 - 30mm (adjustable). The majority of this standard clearance is taken up by the floor covering (e.g. carpet, tiles etc.).

#### 1 Modified clearance under the door.

If you require **more** than 30mm clearance under the door: pack the CS TimberFormed unit off the floor by the extra amount you need.

If you need **less** than 22mm clearance under the door leaf (e.g. for polished timber floors) there are three options to do this:

**A** CS FOR DOORS can supply special seals which fit to the bottom of the door leaves.

**B\*** A door leaf up to 15mm taller can be fitted.

**C\*** The whole unit can be made up to 15mm shorter.

**\*B & C** are only available when **pre-ordered**.

#### 1 Contamination of the top track.

Never drill, nail or screw through the centre section of the track. Make sure no dirt, grit or aluminium swarf gets into the track. This could impair the smooth running of the carriages.

#### 1 Fixing cavity slider to the floor

Installing the cavity slider 100% plumb and level will **NOT** guarantee a correctly sliding door. If any of the wall, lintel, floor and door are not plumb and straight, this can cause the door to slide incorrectly into the pocket.

It is for this reason that the skirting block fixing (found at the base of the cavity slider behind the split jambs) is only secured once you have ensured door is running parallel to the cavity pocket.

## NOW FOR THE INSTALLATION.

### 1 Remove packaging and check components.

Lay the units flat on the ground in front of the door opening.

Remove the transportation cleat (if still fitted) from the bottom plate assembly. (Take out the two screws and the three staples.)

Check for any obvious product defects.

Lay each unit on its back and sight the gap to check for normal clearances (drawing V).

If anything looks out of specification or you are unsure, contact CS before beginning your install.

### 2 Fit the door leaves (if not already fitted). Refer to 'Fitting your own doors' (overleaf).

### 3 Prepare and place both units as a pair into the framed opening in the wall (drawing U and X).

Check that the jack studs on both sides of the door opening are plumb in both directions (drawing U).

Ensure that the tracks are connected neatly together with the alignment pins fitting into the corresponding screw tubes (drawing X).

### 4 Fix the aluminium back studs.

Plumb-up the two timber split jambs (drawing U). Use a level!

While keeping the timber split jambs plumb, pack behind the aluminium back studs as shown. Screw the aluminium back studs including the packing to the 100mm x 50mm jack stud through the pre-punched holes.

**Timber studs:** use 8 gauge x 29mm wood screws.

**Steel studs:** 8 gauge x 29mm self-tapping screws.

### 5 Level the tracks (drawing X).

The tracks must be fitted level and straight.

**Do not** pack above the tracks.

The tracks must be fixed to the lintel at 600mm centres through the aluminium flanges on both sides, starting 50mm from the track meeting point. The screw heads must pull hard up under the aluminium flanges (drawing X).

For **timber** lintels: Use 8 gauge screws penetrating the lintel by at least 25mm.

For **light steel** lintels (under 2mm wall thickness): Use 8 gauge self-tapping screws which penetrate the lintel by at least 5mm.

For **heavy steel** lintels:

Use M5 machine bolts and nuts.

For **Full-Height** (FH) detail option:

The bottom of the track should finish flush with the underside of the finished ceiling (refer to the Additional HowTO Information sheet).

### 6 Fix the bottom plate assembly (drawing Y).

The doors must slide parallel with the bottom plate assembly (see the 2 sets of black **A-A** arrows). If not, gently tap the front of the assembly to the left or right until they do.

The doors should now slide smoothly and butt neatly together when both doors are closed.

Fix the skirting block fixing to the floor only when the cavity pocket has been adjusted so that the **doors slide parallel to the bottom plate of the cavity slider and meet neatly in the middle.**

### 6 Fix bottom plate assembly to the floor as follows:

#### ▮ To **concrete** floors:

Fix with  $\varnothing 8\text{mm}$  x 90mm masonry anchors through the pre-drilled holes in the skirting fixing blocks of the bottom plate.

(See the red stamped arrow on the timber).

#### ▮ To **timber** floors:

Fix the bottom plate assembly with  $\varnothing 3.15\text{mm}$  x 75mm nails on either side in the centre of the skirting fixing block thickness.

(See the red stamped  $\oplus$  on the timber).

Pre-drill  $\varnothing 3\text{mm}$  holes for these nails.

### 7 Adjust the door heights (drawing W).

Use the small end of the spanner supplied to rotate the hexagonal nut at the bottom of the carriage hanger shaft.

Adjust the doors for plumb, making sure they butt neatly together when closed with no gaps.

To **raise** door: Rotate spanner from **left to right**.

To **lower** door: Rotate spanner from **right to left**.

Note: The top of the hanger shaft screws into a self-locking nut. If the hexagonal nut is turned downwards too far, the shaft will become loose from the self-locking nut. If the turning resistance suddenly feels much easier, you have gone too far. With the head jambs not yet fitted, now is a good time to adjust where the doors stop.

The black plastic stop fitted to the mount plate is what contacts the track stop.

Using a 4mm Allen key, loosen the track stops and push them towards the cavity pockets. Gently slide each door towards the centre closed position (where the tracks meet) and then open again. Lock the track stops in place and test that the doors finish where you need them to stop.

### 8 Fit the head jambs

(if not already fitted). (drawing X).

Before fitting head jambs, check that you have the desired clearance under the door, that the two doors meet neatly together and are plumb (instruction 7). Slide the head jambs into place between the vertical jambs.

This goes for both grooved and architraved jambs: 'Flush up' the joints. Then screw them into place with the 8 gauge x 32mm long countersunk head screws (as supplied). Gently tap wooden plugs to cover the screw heads. For Serveries units (SERV) the sill is not included unless asked for.

## FINISHING THE INSTALLATION.

### 9 Fixing the wall linings.

The cavity slider comes with split jambs intentionally 'rounded out' as shown (drawing V). This round out is to accommodate any slight bowing of the door leaf and to allow door hardware to clear the jambs.

The supplied 'jamb spreader' should be inserted into the cavity slider opening prior to fixing wall linings and architraves.

Wherever possible, linings should only be glued on. Use short drywall screws to hold linings in place until glue is dry. For 10mm linings use maximum 25mm long drywall screws.

We recommend sealing the inside of all plasterboard linings and mdf architraves.

Go to page **4** (overleaf) 

# U ELEVATION See points 3 and 4.

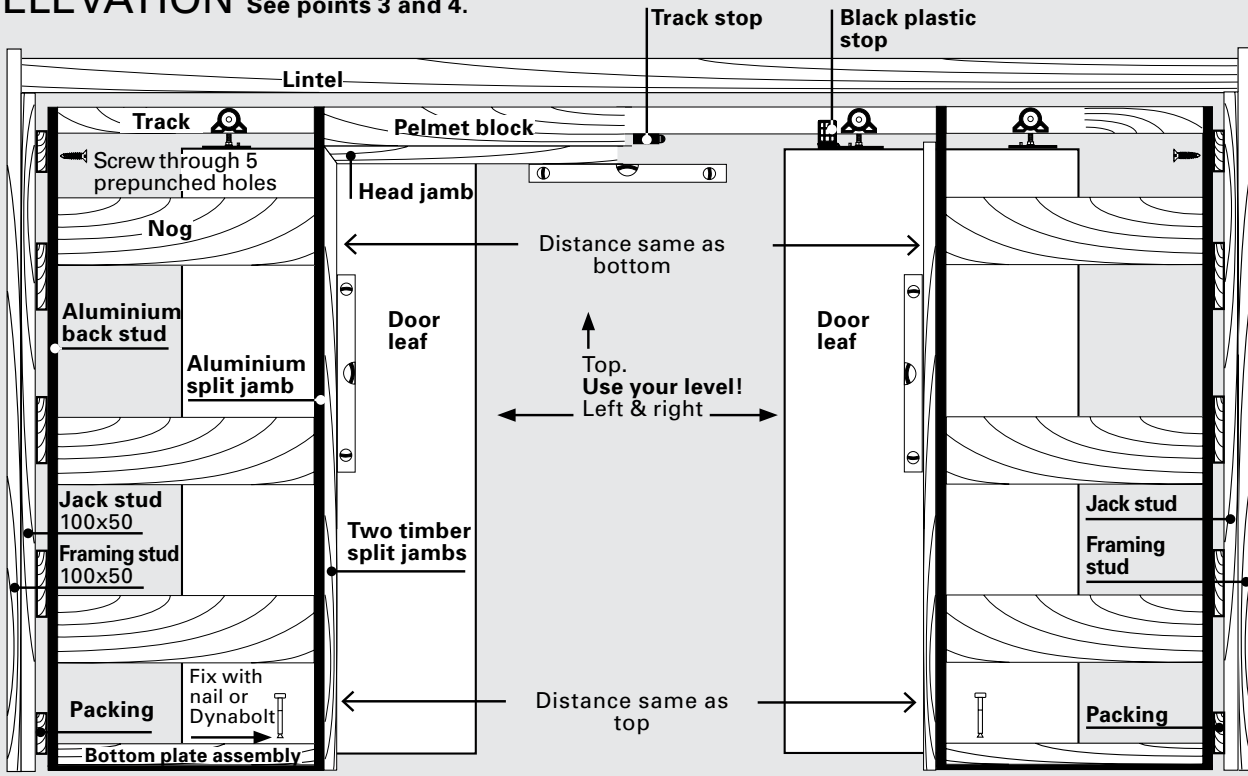

# W ADJUSTING & REMOVING CarriSnap™ CARRIAGES

See points 7, 12 & 14.

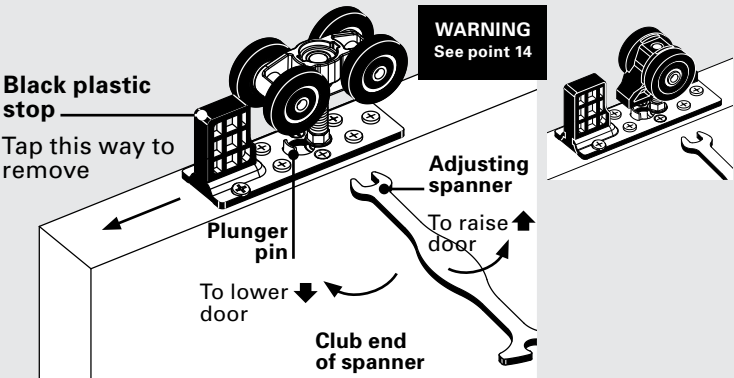

# V JAMB CLEARANCE

See points 1 and 9.

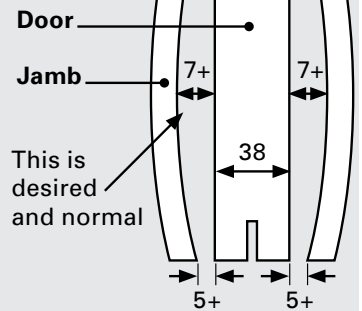
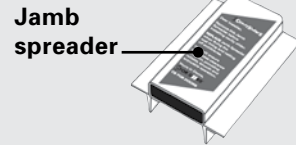

# Y BOTTOM PLATE ASSEMBLY

See points 6 and 11.

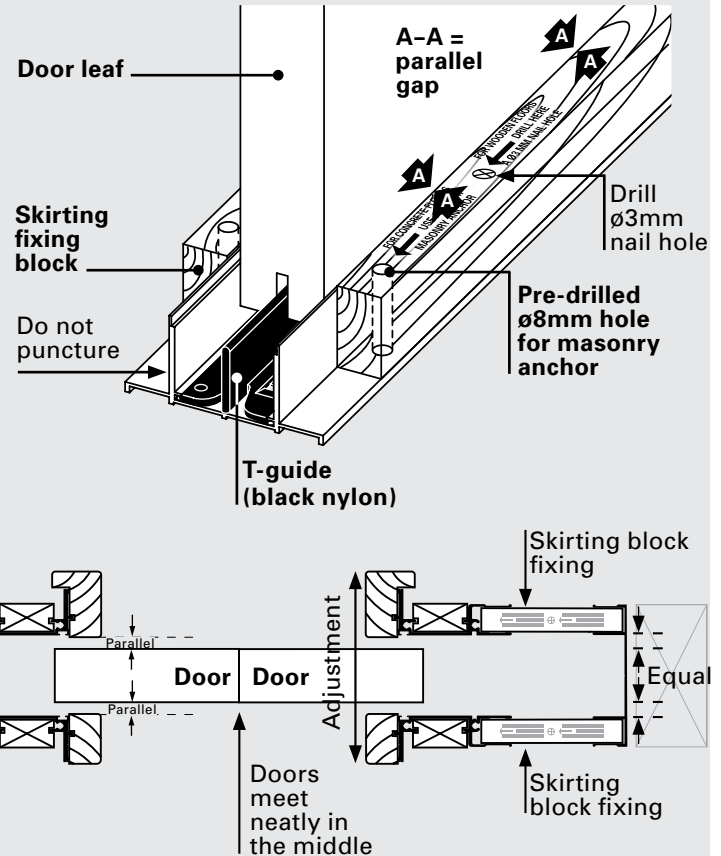

# X TRACK CROSS SECTION

See points 3, 5, 8 & 10.

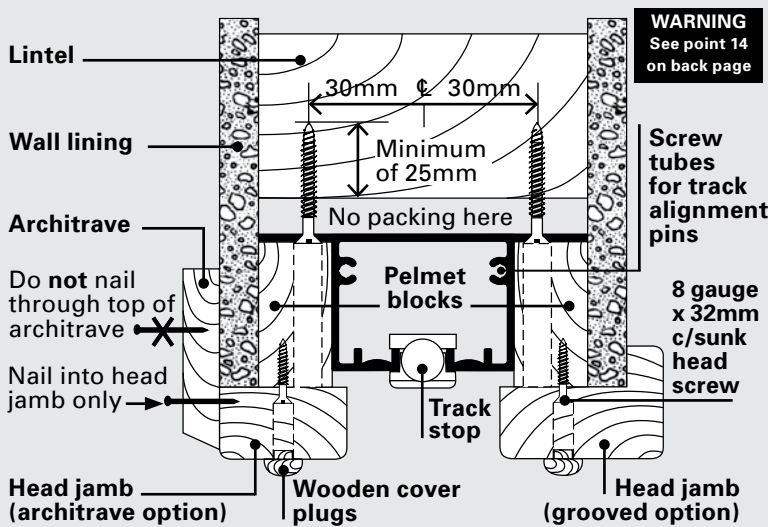

## 10 If fitting architraves (drawing X).

Nail the architraves to the four vertical jambs and the two horizontal head jambs.

Use panel pins with a maximum length of 25mm plus the thickness of the architrave.

Nail the back of the architrave to the split jamb blocks using panel pins with a maximum length of the combined thickness of the architrave and wall linings **plus** 15mm.

Note: Nail the horizontal architraves to the head jambs; however do **not** nail them to the timber pelmet blocks above the head jamb.

## 11 If fitting skirtings (drawing Y).

When you fix the skirtings, make sure that you do **not** puncture the aluminium extrusion of the bottom plate assembly.

The maximum length of the panel pins are the combined thickness of the skirting and the wall lining **plus** 17mm.

**Do not hammer too hard against the bottom plate. This may damage the channel through which the door leaf slides.**

## 12 Removing the door leaves (drawing W).

Begin by removing the head jamb from one side (if fitted).

Fit the club end of the adjusting spanner over the hexagonal nut at the bottom of the hanger pin (drawing W).

Use the extended part of the spanner to press down the plunger pin that protrudes up from the mounting plate. Once this plunger is fully depressed, slide the spanner sideways towards the plunger pin.

The whole carriage (including the shaft) will now disengage from the mounting plate.

It is not always easy to slide the spanner sideways. You may need to relieve the door's weight by putting a wedge between door and floor.

Do the same with the other carriages.

Finally, remove the black plastic stop that is tightly fitted into the mounting plate at the front of each door leaf. Remove this by tapping it out in the direction shown using a hammer and drift. (drawing W).

If you want to take the carriages out: Slide them towards the centre of the opening.

Use a 4mm Allen key to remove the track stops fitted in the middle where the doors meet.

## 13 Fitting your own doors (drawing Z).

At the bottom of the door leaf cut a groove to the dimension and tolerance shown (drawing Z). Make it central to the door thickness and absolutely straight.

Drill mounting plate holes to the correct size and depth as marked (drawing Z).

Fix both mounting plates to the door. The larger of the two mounting plates (the one with the black plastic stop) fits closest to the leading edge of the door. Make sure the black plastic stop is facing the leading edge of the door.

Remove the track stops from the centre of each track (drawing Y) by loosening the two stainless steel cap screws.

Slide the stops to the centre of the track where they will drop out through the carriage access slot.

Load the carriages into the track through the notch in the track.

4  
PAGE

13 Position the door underneath the carriages. Raise the door up so that the round head of the wheel hanger shaft lines up with the keyhole shaped hole in the mounting plate (drawing Z).

Depress the plunger using the wheel hanger shaft head and slide sideways until it snaps into locked position. Repeat for the other carriages.

Re-fit the track stops to the tracks with each rubber buffer part pointing towards the cavity pocket. Temporarily tighten the cap screws.

Continue at instruction 3 on page 3.

## 14 **WARNING** (drawing W and X).

**CS Cavity Sliders require the track running surface to be clean and free of any contamination or damage. For smooth reliable service, the tyres on the carriage should not be chipped, dented or have swarf embedded in the tyre.**

Please ensure you take extra care with the carriages to avoid any damage during the installation process.

5  
PAGE

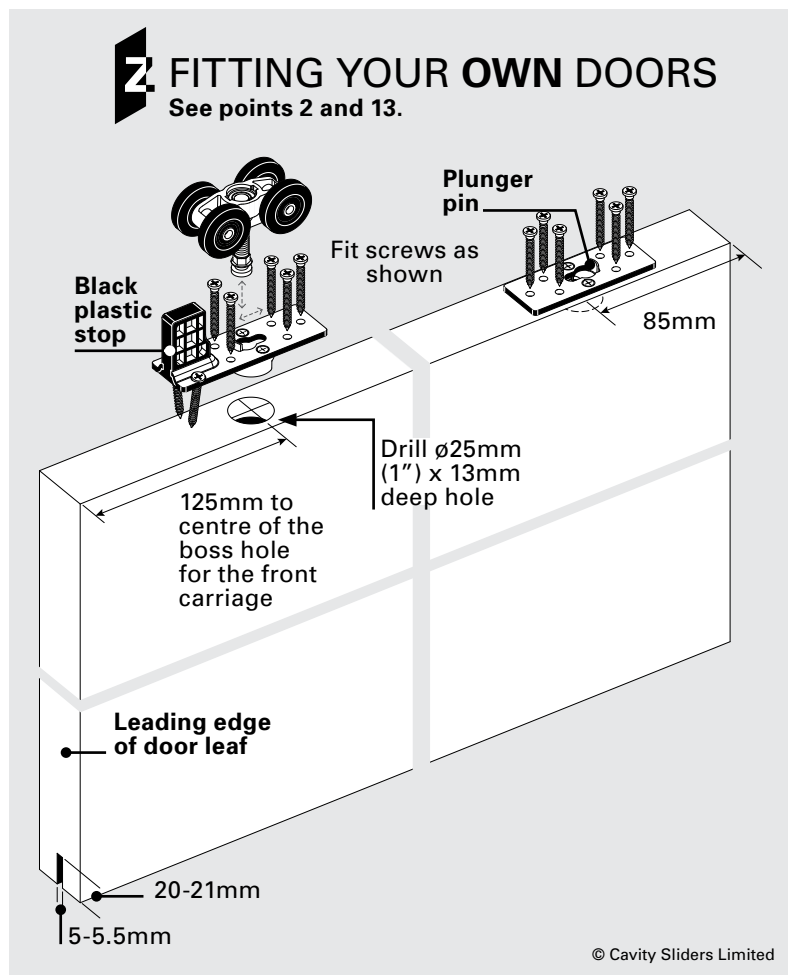

© Cavity Sliders Limited

**Cavity Sliders Limited**  
**Auckland Head Office**

5 - 7 Rakino Way  
Mt Wellington

PO Box 112349, Penrose  
Auckland 1642, NZ

T 09 276 0800

F 09 276 2525

**FOR DOORS**

info@csfordoors.co.nz  
www.csfordoors.co.nz

**CavitySliders**

For doors that <slide> inside walls

All copyright and other property in this document is reserved by Cavity Sliders Limited. Details and specifications are subject to change without notice. Whilst all care is taken to ensure the accuracy of all information, no responsibility will be accepted for any errors or omissions.

\*Guarantee conditions apply. Contact CS FOR DOORS for details.

© CS FOR DOORS and CS Cavity Sliders are Registered Trademarks. New Zealand Patent No: 533838.

Go to page **5** →