

DynaFlash Universal Back Flashing  
External Corner

Scale:	1:2
Do not scale from drawings. Contact Dynex Extrusions Ltd for exact dimensions <a href="http://www.Dynex.co.nz">www.Dynex.co.nz</a> 0800 4 DYNEX (0800 4 39639)	
Date:	Oct 2016
Detail No:	<b>DF - 01</b>

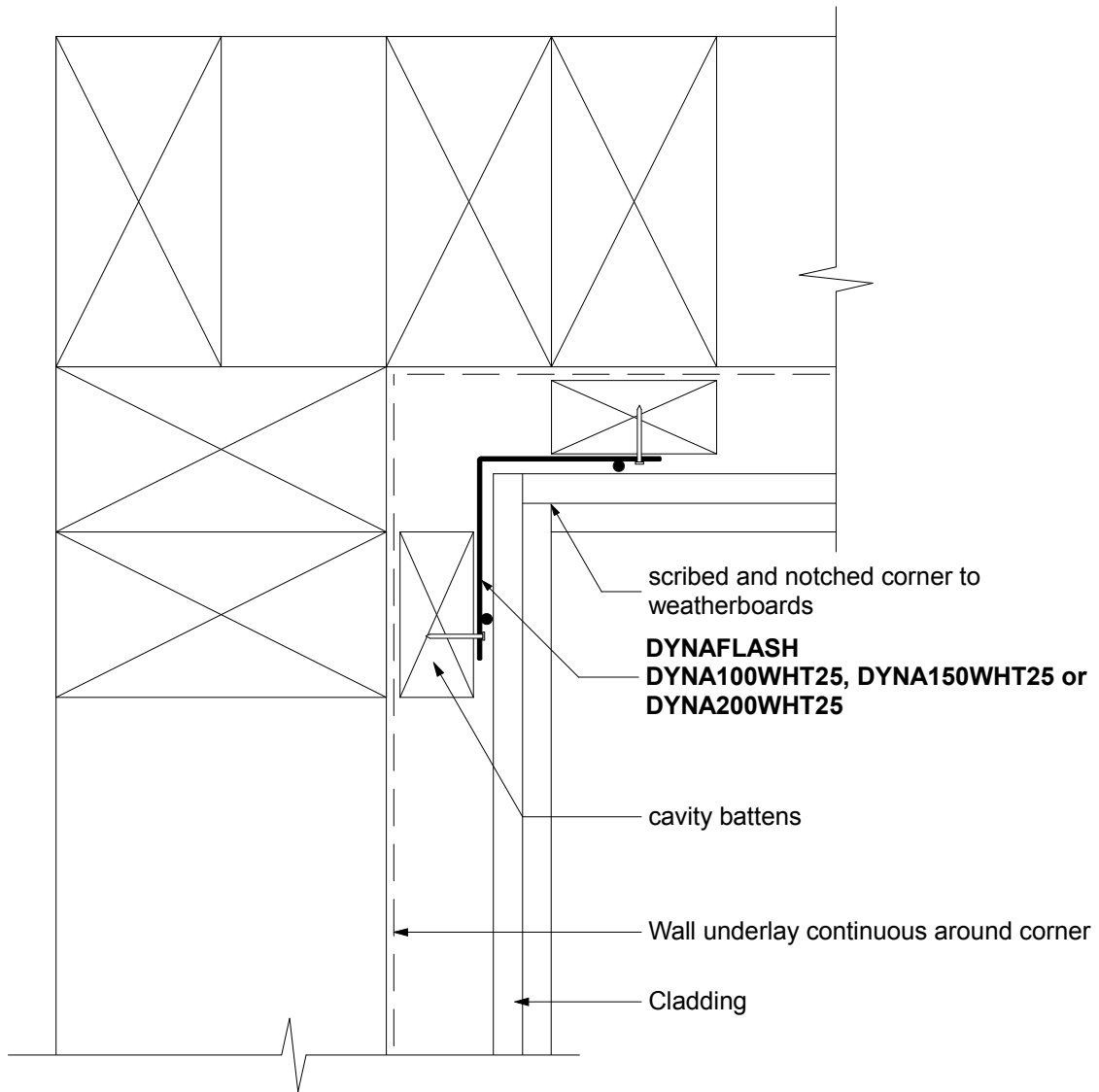

DynaFlash Universal Back Flashing  
 Internal Corner

Scale:	1:2
Do not scale from drawings. Contact Dynex Extrusions Ltd for exact dimensions <a href="http://www.Dynex.co.nz">www.Dynex.co.nz</a> 0800 4 DYNEX (0800 4 39639)	
Date:	Oct 2016
Detail No:	<b>DF - 02</b>

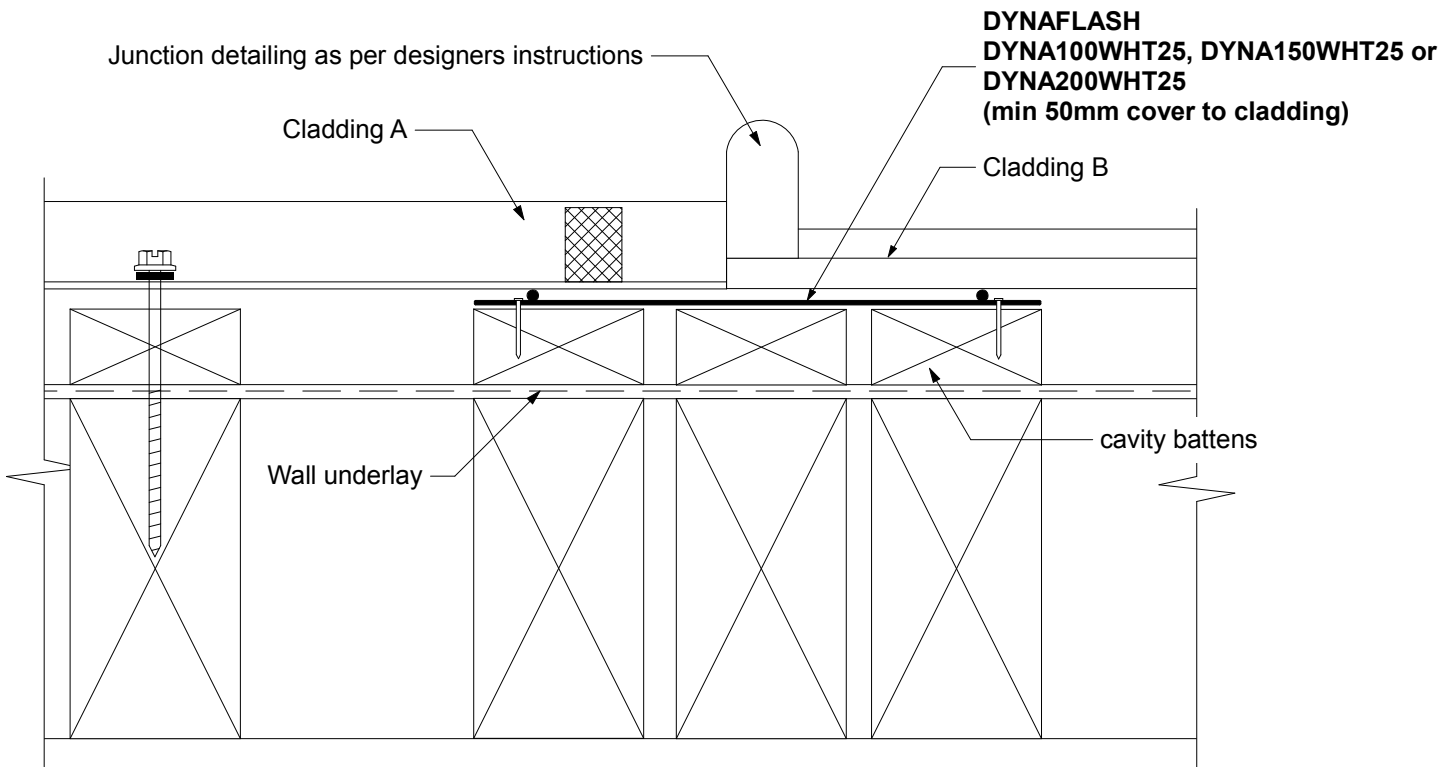

DynaFlash Universal Back Flashing  
Flat Transition

Scale:	1:2
Do not scale from drawings. Contact Dynex Extrusions Ltd for exact dimensions <a href="http://www.dynex.co.nz">www.dynex.co.nz</a> 0800 4 DYNEX (0800 4 39639)	
Date:	Oct 2016
Detail No:	<b>DF - 03</b>

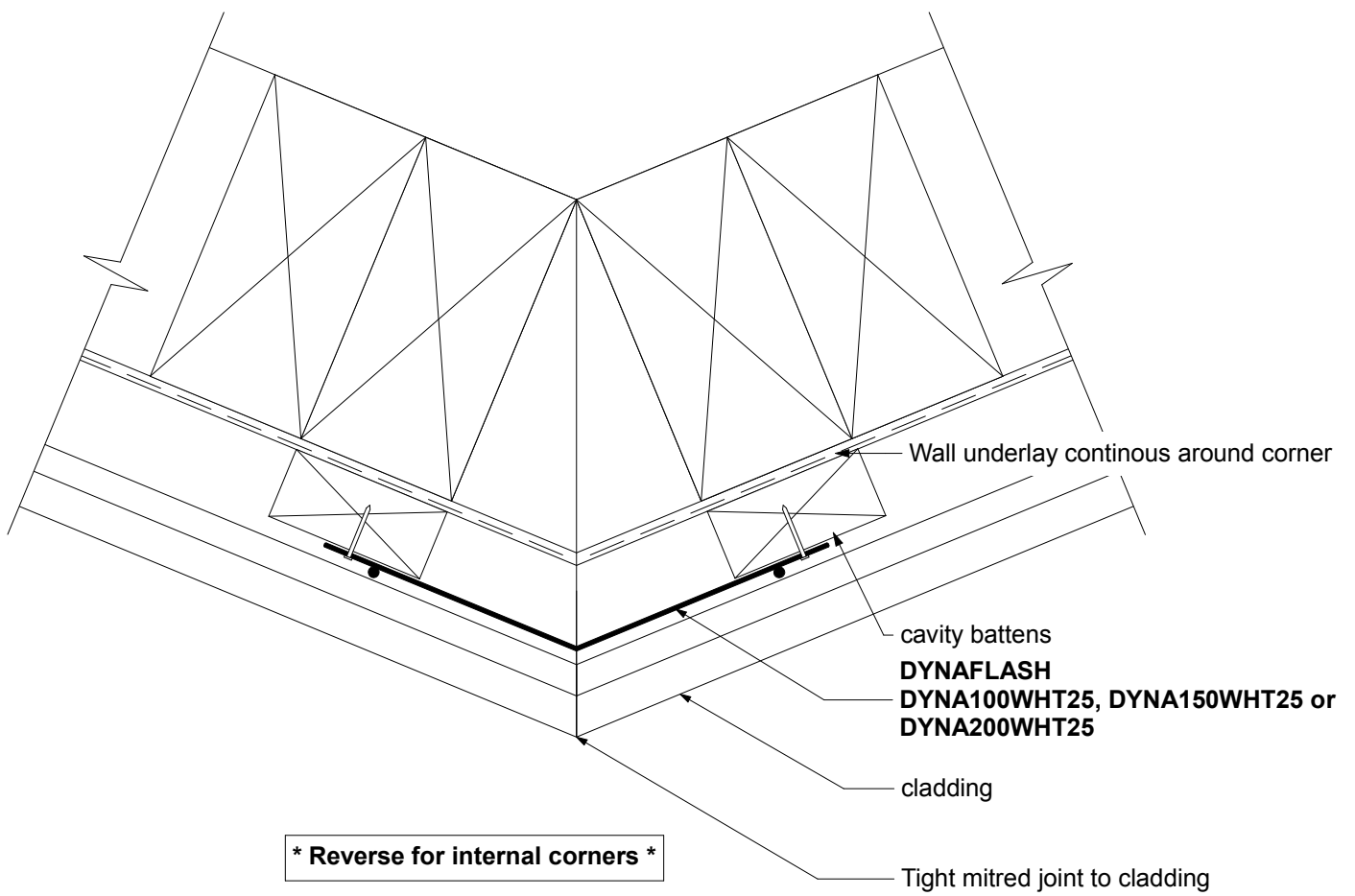

DynaFlash Universal Back Flashing  
 Angled Corner

Scale:	1:2
Do not scale from drawings. Contact Dynex Extrusions Ltd for exact dimensions <a href="http://www.dynex.co.nz">www.dynex.co.nz</a> 0800 4 DYNEX (0800 4 39639)	
Date:	Oct 2016
Detail No:	<b>DF - 04</b>

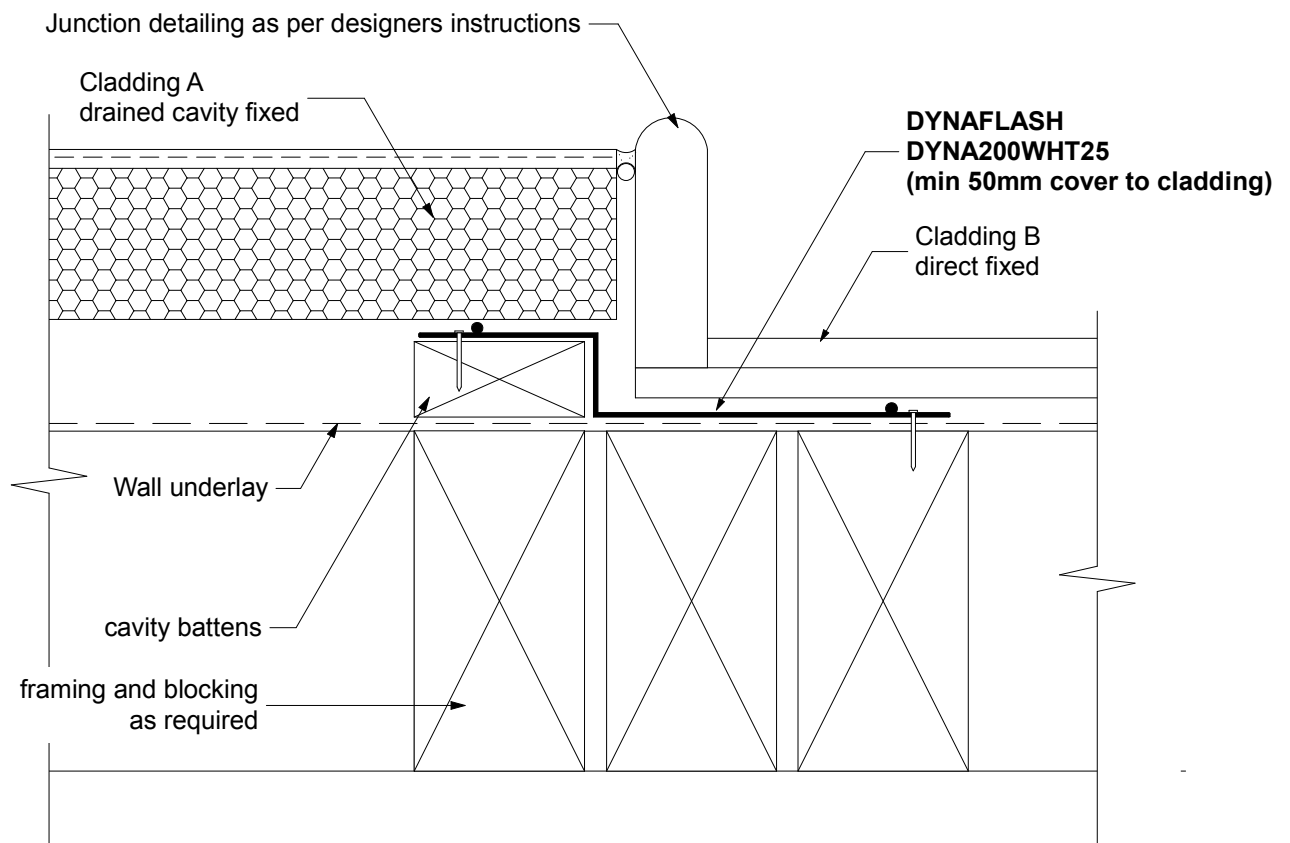

DynaFlash Universal Back Flashing  
 "Z" Flashing Transition

Scale:	1:2
Do not scale from drawings. Contact Dynex Extrusions Ltd for exact dimensions <a href="http://www.dynex.co.nz">www.dynex.co.nz</a> 0800 4 DYNEX (0800 4 39639)	
Date:	Oct 2016
Detail No:	<b>DF - 05</b>

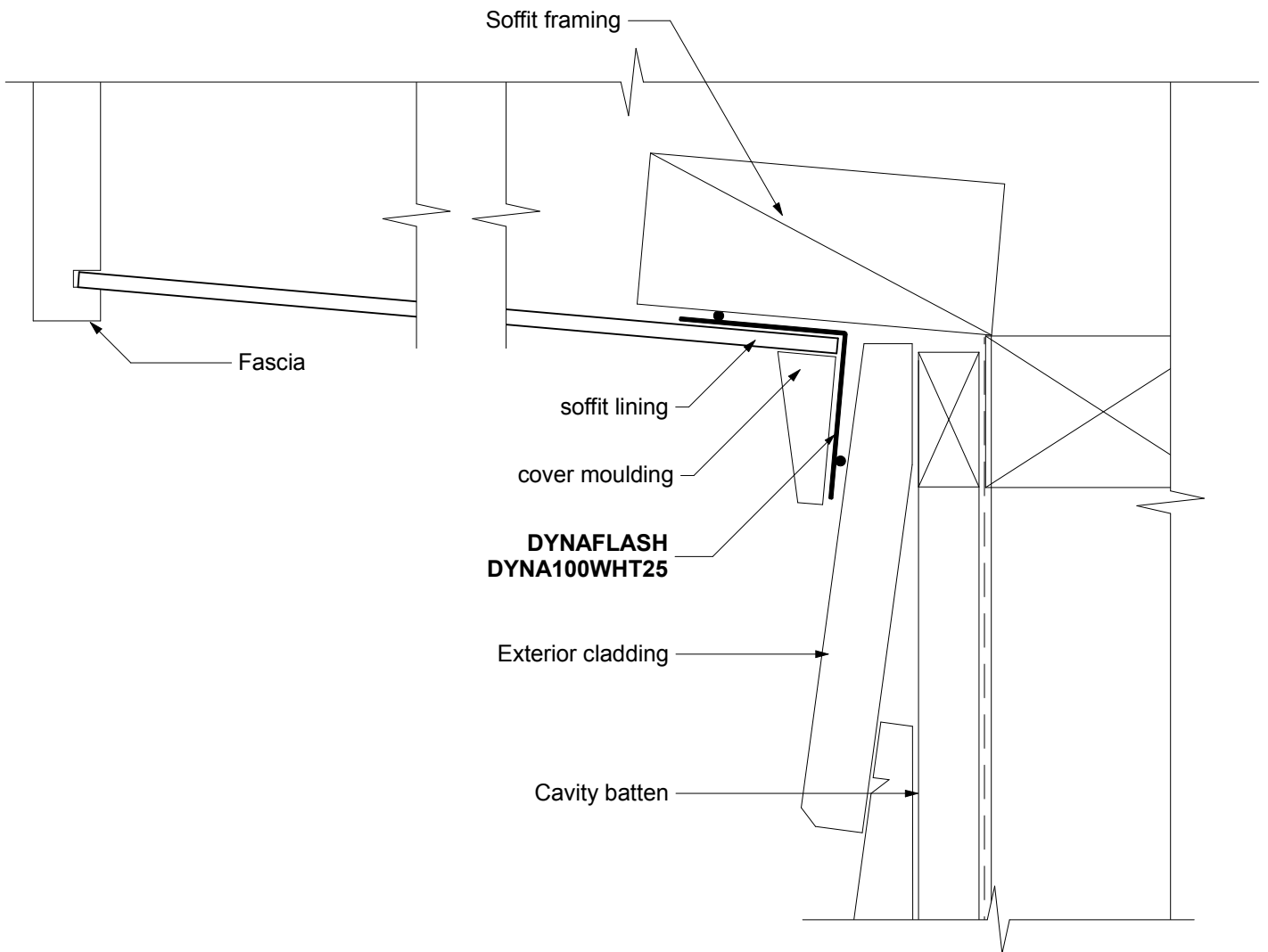

DynaFlash Universal Back Flashing  
Reverse Raking Soffit

Scale:	1:2
Do not scale from drawings. Contact Dynex Extrusions Ltd for exact dimensions <a href="http://www.Dynex.co.nz">www.Dynex.co.nz</a> 0800 4 DYNEX (0800 4 39639)	
Date:	Oct 2016
Detail No:	<b>DF - 06</b>