



Installation Manual

Content

1	Introduction	3	7	Waterproofing	16
2	Safe working practices	5	8	Finishes	17
3	Framing	7	9	Maintenance	18
3.1	General	7	10	Product information	18
3.2	Loading Consideration	7		Product warranty	19
3.3	Framing Set Out	7			
3.4	Sub Floor Ventilation	8			
4	Internal floor — dry area	8			
4.1	Tile and Slate Underlay Installation	8			
4.2	HardiePanel Compressed Sheet Installation	11			
5	Internal floor — wet area	12			
5.1	Tile and Slate Underlay Installation	12			
5.2	HardiePanel™ Compressed Sheet Installation	12			
5.3	Control Joints	12			
6	External deck	13			
6.1	HardiePanel™ Compressed Sheet Fixing	13			
6.2	Jointing Options	13			
6.3	Deck Jacks	15			

WE VALUE YOUR FEEDBACK

To continue with the development of our products and systems, we value your input. Please send any suggestions, including your name, contact details, and relevant sketches to:

Ask James Hardie™

Fax 0800 808 988

literaturefeedback@jameshardie.co.nz

1 Introduction

James Hardie manufactures three types of fibre cement flooring products which can be used as a substrate to lay tiles, heavy grade vinyl or cork over for use in dry or wet area applications. These products provide a durable, strong and moisture resistant substrate which helps to minimise tile cracking and reduce damage from moisture ingress.

Tile and Slate Underlay is an internal flooring underlay sheet with a pre-marked nailing pattern on the face of the sheet. Its main features are:

- Larger board size which is ideal for bigger bathrooms and other large floor areas being tiled.
- Smaller board size is ideal for smaller bathrooms or hard to get to projects where floor areas are being tiled.
- Can be easily cut with a score and snap knife.
- Pre-sealed to improve tile adhesion.

HardiePanel™ Compressed Sheet is an 18mm thick high density sheet which can be used as internal flooring or external decking. HardiePanel Compressed Sheet may be covered with vinyl, tiles, marble, slate or granite etc. It may be used for internal floors where heavy duty, impact resistant or a water resistant floor is required. HardiePanel Compressed is particularly suitable where mortar beds or epoxy screeds are used to create a fall to waste with a tiled finish in areas like bathrooms and laundries.

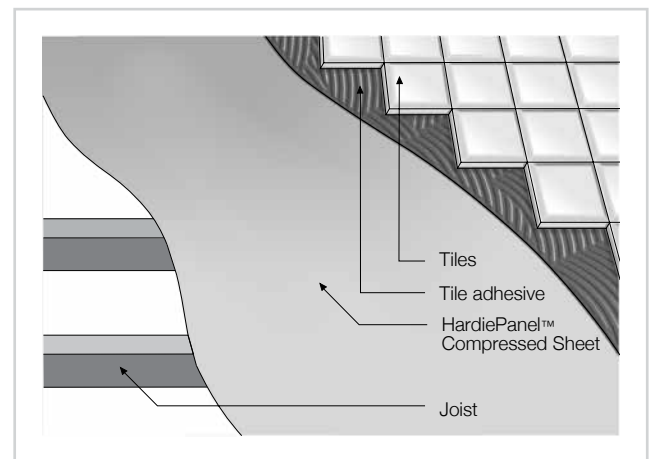
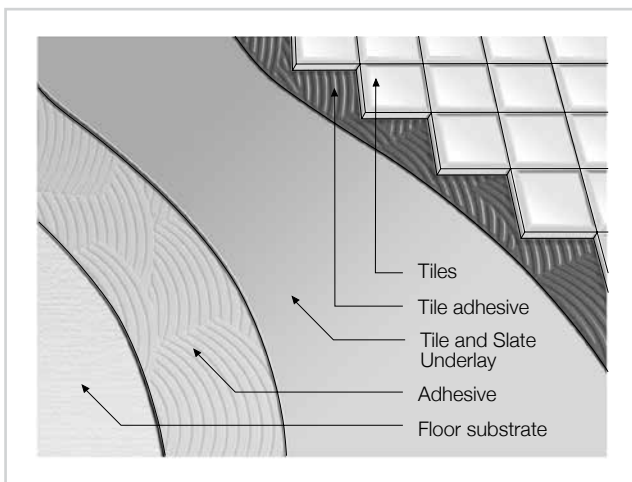

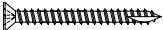
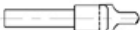
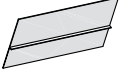

Table 1

James Hardie product information			
PRODUCT	DESCRIPTION	SIZE (MM)	CODE
	18mm HardiePanel Compressed Sheet	2400 x 1200	400094
	Used under tiles / marble / slate/ granite / treadable exterior coatings	1800 x 1200	400096
	Tile and Slate Underlay	1800 x 1200	403341
	6mm underlay sheet with pre-marked nailing pattern on the face.	1800 x 900	400418
	Suitable for tiles	1800 x 600	404110







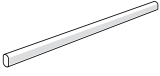

Scyon® Secura™ Interior Flooring is a 19mm thick low density presealed sheet which is used as internal flooring. Please refer to the Scyon Secura Interior Flooring Installation Manual for more details.

Table 2

Accessories supplied by James Hardie					
ACCESSORIES	DESCRIPTION	PRODUCT CODE	ACCESSORIES	DESCRIPTION	PRODUCT CODE
	Underlay nails To fix Tile and Slate underlay 25 x 2.5mm annular threaded galv. nails. Selling unit: 500g	300390		HardieBlade Saw Blade 185mm diameter Used to cut HardiePanel Compressed Sheet	300660
	Compressed Sheet Screw To fix HardiePanel Compressed Sheet Stainless steel 316 50mm x 10g (100/Jar)	300904		Tungsten Carbide Drill Bit 18mm: to predrill holes for Compressed Sheet Screw	300566
	Aluminium 'T' Socket 2400	304103			

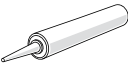
Accessories not supplied by James Hardie

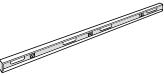
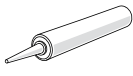
James Hardie recommends the following products for use in conjunction with its flooring products. James Hardie does not supply these products and does not provide a warranty for their use. Please contact the component manufacturer for information on their warranties and further information on their products.

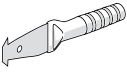
ACCESSORIES	DESCRIPTION	ACCESSORIES	DESCRIPTION
	Backing rod Backing to be used with sealant in movement joints.		Notched trowel For adhesive application on the floor.
	Sander For sanding uneven underlying flooring.		Solvent adhesive Used for adhering underlay onto particle board or plywood floors in tiled applications.
	Sealant Suitable sealant for use in movement joints.		Waterproofing membrane Used over the underlay in wet areas. Use the approved products and applications.
	Level/straight edge For checking straightness of underlying flooring.		Socket adhesive Sika Super Grip® 30mins
	Paslode nail gun B40210 Used to fire nails into Tile and Slate Underlay.		25 x 3.06mm nail D40201 Used in Paslode B40210 nail gun to fix Tile and Slate Underlay
	Score and Snap knife To cut Tile and Slate Underlay		

2 Safe working practices

WARNING – DO NOT BREATHE DUST AND CUT ONLY IN WELL VENTILATED AREA

James Hardie products contain sand, a source of respirable crystalline silica which is considered by some international authorities to be a cause of cancer from some occupational sources. Breathing excessive amounts of respirable silica dust can also cause a disabling and potentially fatal lung disease called silicosis, and has been linked with other diseases. Some studies suggest smoking may increase these risks. During installation or handling: (1) work in outdoor areas with ample ventilation; (2) minimise dust when cutting by using either 'score and snap' knife, fibre cement shears or, where not feasible, use a HardieBlade™ Saw Blade and dust-reducing circular saw attached to a HEPA vacuum; (3) warn others in the immediate area to avoid breathing dust; (4) wear a properly-fitted, approved dust mask or respirator (e.g P1 or P2) in accordance with applicable government regulations and manufacturer instructions to further limit respirable silica exposures. During clean-up, use HEPA vacuums or wet cleanup methods — never dry sweep. For further information, refer to our installation instructions and Safety Data Sheets available at www.jameshardie.co.nz.

FAILURE TO ADHERE TO OUR WARNINGS, SAFETY DATA SHEETS, AND INSTALLATION INSTRUCTIONS MAY LEAD TO SERIOUS PERSONAL INJURY OR DEATH.

James Hardie recommended safe working practices

CUTTING OUTDOORS

1. Position cutting station so wind will blow dust away from user or others in working area.
2. Use one of the following methods to cut Tile and Slate Underlay based on the required cutting rate:

BEST

- Score and snap
- Hand guillotine
- Fibreshear

BETTER

- Dust reducing circular saw equipment with HardieBlade™ Saw Blade and HEPA vacuum extraction.

GOOD

- Dust reducing circular saw equipped with HardieBlade™ Saw Blade.

3. Use the following method to cut HardiePanel Compressed Sheet:

BEST

- Dust reducing circular saw equipment with HardieBlade™ Saw Blade and HEPA vacuum extraction.

GOOD

- Dust reducing circular saw with HardieBlade™ Saw Blade.

CUTTING INDOORS

- Cut only using score and snap, hand guillotine or fibreshears (manual, electric or pneumatic).
- Position cutting station in well-ventilated area.

SANDING/DRILLING/OTHER MACHINING

When sanding, drilling or machining you should always wear a P1 or P2 dust mask and warn others in the immediate area.

IMPORTANT NOTES:

1. PFor maximum protection (lowest respirable dust production), James Hardie recommends always using "Best" — level cutting methods where feasible.
2. PNEVER use a power saw indoors
3. PNEVER use a circular saw blade that does not carry the HardieBlade logo
4. NEVER dry sweep — Use wet suppression or HEPA Vacuum
5. NEVER use grinders
6. ALWAYS follow tool manufacturer's safety recommendations

P1 or P2 respirators should be used in conjunction with above cutting practices to further reduce dust exposures. Additional exposure information is available at www.jameshardie.co.nz to help you determine the most appropriate cutting method for your job requirements. If concern still exists about exposure levels or you do not comply with the above practices, you should always consult a qualified industrial hygienist or contact James Hardie for further information.

WORKING INSTRUCTIONS

Refer to recommended Safe Working Practices before starting any cutting or machining of product.

SCORE-AND-SNAP

Score-and-snap is a fast and efficient method of cutting James Hardie Tile and Slate Underlay using special tungsten tipped score-and-snap knife.

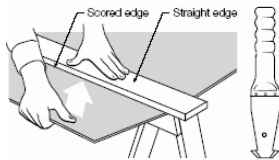

Preferably score on the face side of the product. Score against a straight edge and repeat the action to obtain adequate depth for clean break — normally one third of sheet thickness. Snap upwards to achieve break. Smooth any rough edges with a rasp.

HAND GUILLOTINE

Tile and Slate Underlay can be cut using hand guillotine method. Make guillotine cut on the off-cut side of line to allow for the thickness of the blade.

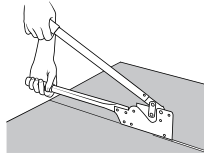

FIBRESHEAR

An electrically powered, fast, clean and effortless way of cutting James Hardie Tile and Slate Underlay, especially around curves such as archways. Make fibreshear cut on the 'off-cut' side of the line to allow for the thickness of the shear.

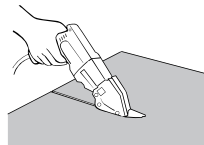

HARDIEBLADE SAW BLADE

The HardieBlade Saw Blade used with a dust-reducing saw connected to a HEPA vacuum allows for fast, clean cutting of HardiePanel Compressed Sheet and Tile and Slate Underlay. A dust-reducing saw uses a dust deflector or a dust collector connected to a vacuum system. When sawing, clamp a straight-edge to the sheet as a guide and run the saw base plate along the straight edge when making the cut.

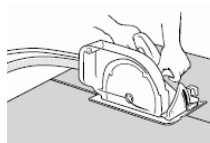

HOLE-FORMING

For smooth clean cut circular holes:

Mark the centre of the hole on the sheet. Pre-drill a 'pilot' hole.

Using the pilot hole as a guide, cut the hole to the appropriate diameter with a hole saw fitted to a heavy duty electric drill.

For irregular holes:

Small rectangular or circular holes can be cut by drilling a series of small holes around the perimeter of the hole then tapping out the waste piece from the sheet face.

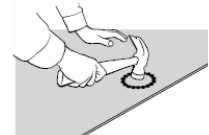

Tap carefully to avoid damage to sheets, ensuring that the sheet edges are properly supported.

STORAGE AND HANDLING

To avoid damage, all James Hardie building products should be stored with edges and corners of the sheets protected from chipping.

James Hardie building products must be installed in a dry state and protected from rain during transport and storage. The product must be laid flat under cover on a smooth level surface clear of the ground to avoid exposure to water, moisture, etc.

QUALITY

James Hardie conducts stringent quality checks to ensure that any product manufactured falls within our quality spectrum. It is the responsibility of the builder to ensure that the product meets aesthetic requirements before installation. James Hardie will not be responsible for rectifying obvious aesthetic surface variations following installation.

3 Framing

3.1 GENERAL

All construction must be carried out in accordance with the relevant building regulations and standards. Prior to installation, ensure the new / existing flooring and supporting framing is suitable.

Tile and Slate Underlay is suitable as a substrate for tiles over internal timber, particle board, plywood floors or composite flooring substrates in wet and dry areas.

A waterproofing membrane must be applied over the Tile and Slate Underlay or HardiePanel Compressed Sheet in internal wet areas prior to the installation of tiles.

Notes

1. Tile and Slate Underlay or HardiePanel Compressed Sheet must not be used on concrete slabs.
2. To build up height of concrete, purpose-made concrete levelling compounds are more suitable.
3. For tiling of internal walls use James Hardie Villaboard® Lining as the tiling substrate.

3.2 LOADING CONSIDERATION

HardiePanel Compressed Sheet is a structural flooring product which is fixed directly over the floor joists.

For residential applications, Table 3.1 of AS 1170.1 specifies a concentrated load of 1.8kN applied over an area of 350mm² or bigger. For other residential and commercial applications, the concentrated loads of 2.7kN, 3.5kN and 4.5kN are specified applied over an area of 0.01m² ie 100mm square applicator.

HardiePanel Compressed Sheet can sustain a maximum allowable loading as per Table 3.

Table 3

Maximum allowable load		
JOIST SPACING (mm)	UNIFORM DISTRIBUTED LOAD (kPa)	CONCENTRATED LOAD (kN)
400	21.1	2.7
600	8.8	

Loads heavier than these specified in the table above must be considered at the design stage.

Notes

1. The deflection limit of span/200 (sls) has not been exceeded.
2. The concentrated loads can be sustained under load applicator 350mm² or greater.
3. The above capacities are working loads that need to be factored in accordance to Section 4 of AS/NZS 1170.0 to get uls loading.
4. A working load of 1kPa has been allowed for partitioning walls and floor coverings while establishing the capacities in Table 3.
5. HardiePanel Compressed Sheet will provide these capacities even if it becomes saturated.

Contact your builder, designer or engineer if in doubt or Ask James Hardie 0800 808 868.

3.3 FRAMING SET OUT

3.3.1 NEW FLOORS

Timber framing must either be in accordance with NZS 3604 'Timber Framed Buildings' or be as per specific design to AS/NZS 1170 'Structural Design Actions' and NZS 3603 'Timber Structure Standard'.

Floor joists must be 45mm minimum wide.

The framing centres must not exceed those given in this installation manual. When referring to NZS 3604 for floor joist spans, it is recommended that the spans are reduced to 80% of maximum span specified in this standard.

The framing member widths must conform to the sizes provided in this installation manual.

Moisture content in timber floor joists must not exceed 20% at the time of installation of HardiePanel Compressed Sheet.

When fixing Tile and Slate Underlay over wooden particle board or plywood floors, the moisture content in these substrates must be less than 16%.

For further timber treatment and allowable moisture content information refer to NZS 3602 'Timber and Wood-Based Products for use in Buildings' and NZS 3640 'Chemical Preservation of Round Sawn Timber' for minimum timber treatment selection and treatment requirements. Also refer to framing manufacturer's literature for further guidance on timber selection. Framing must be protected from moisture on site in accordance with the framing manufacturers recommendations.

3.3.2 FOR TILED FLOORS

For fixing Tile and Slate Underlay, ensure that the substrate is suitably rigid to accept tiles. The deflection in a substrate can crack the floor tiles.

For fixing HardiePanel Compressed Sheet for tiled applications, the floor joists must be provided at 400mm centres maximum and nogs at maximum 1200mm centres to support all sheet edges (refer Figure 9).

Note

Floor joists @ 400mm c/c maximum spacing is required to ensure minimal deflection. Tile grouts and adhesives can be detrimentally affected by even small deflections. For tiled applications reduce spans specified in NZS 3604 by 20%.

3.3.3 FOR UN-TILED FLOORS

Floor joists shall be provided at maximum 600mm centres and nogs at maximum 1200mm centres, to support all sheet edges (refer Figure 6).

4 Internal floor — dry area

3.3.4 EXISTING TIMBER FLOORS

Remove all existing floor coverings to expose timber flooring. Check floor boards to make sure they are firmly nailed to the floor joist. Loose boards must be re-fixed firmly into floor joists.

Floor boards must be reasonably flat for Tile and Slate Underlay. If the boards are badly warped or cupped the whole floor should be rough sanded to level off the surface before Tile and Slate Underlay is fixed.

Bearers must be in contact with piles. If they aren't, they should be packed to ensure there is no deflection / settlement expected in the floor.

Ensure the floor is clean of dust, dirt and grease before fixing underlay sheets.

3.4 SUB FLOOR VENTILATION

Check that adequate ventilation exists under all timber floors (especially new floors) and that the areas are free from damp. Refer to NZS 3604 for ventilation requirements.

4.1 TILE AND SLATE UNDERLAY INSTALLATION

SUBSTRATE PREPARATION

Step 1

Use a straight edge to check that the floor is not out of level by more than 1mm over a 1m length.



Step 2

If the floor is warped or cupped the whole floor should be rough sanded before the underlay is fixed.



Step 3

Ensure floor substrate and James Hardie underlay sheets are clean of dust, dirt and grease before fixing underlay sheets.



CUTTING

Use a straight edge as a guide when scoring Tile and Slate Underlay. Score the face of the sheet.

Firmly support sheet near cut while snapping upward to break.

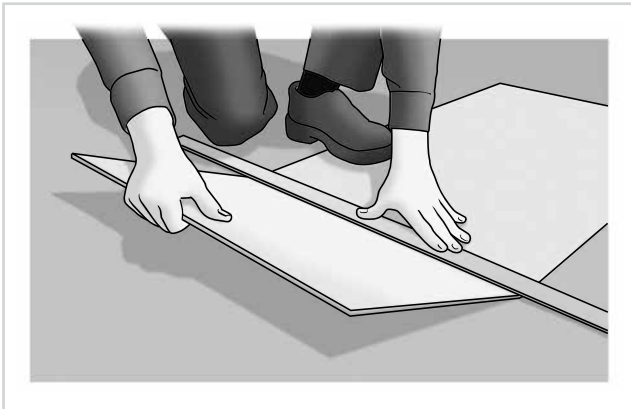

TILED FLOOR APPLICATIONS UNDERLAY FIXING

When fixing tile and slate underlay over particle board / plywood / composite flooring substrates adhesive must be used in addition to nails.

Spread adhesive on the back of the underlay sheet with a 3mm notched trowel/spreader, paying particular attention to the sheet edges. Alternatively apply a 5mm continuous bead of adhesive at 50mm centres, paying particular attention to the sheet edges.

Tile and slate underlay can be fixed only using the nails when fixed to tongue and groove timber floors or hardwood floors.

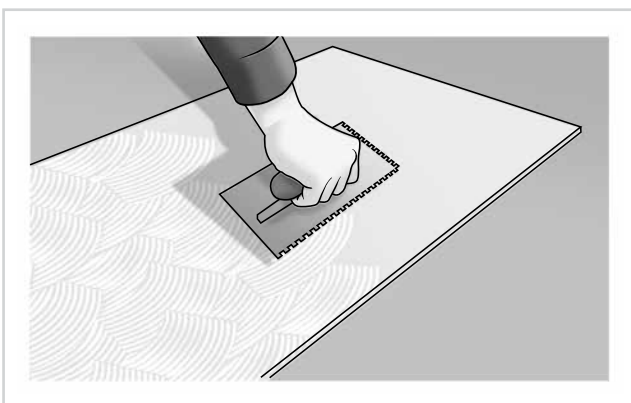

Sheets are laid closely in a staggered (brick) pattern. Sheets are laid perpendicular to the direction of flooring substrate, as joints must not coincide with the joints in the timber floor (minimum offset of 100mm is required for sheet flooring substrates). Ensure Tile and Slate Underlay is fixed to allow 5mm gap between wall and sheet edge. Temporarily fix each sheet with two or three nails to avoid movement. Fill gap between underlay and wall with flexible sealant.

Typical fixing of Underlay Sheet for tiled floors:

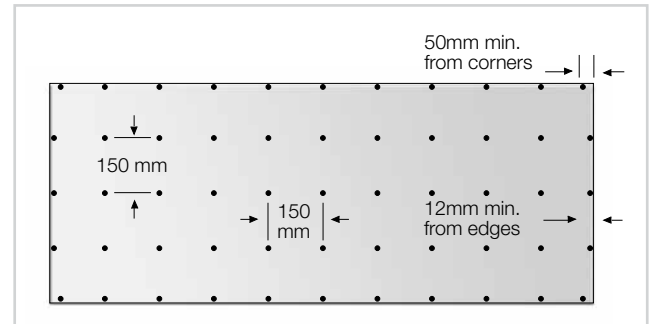

Fix sheets from the centre outwards using the pre-marked nailing pattern, driving fasteners flush with the sheet surface. Use 25 x 2.5mm underlay nails or the 25 x 3.06mm coil nail.



Apply tile adhesive over Tile and Slate Underlay in accordance with adhesive manufacturer's recommendations.

Install tiles in accordance with tile manufacturer's recommendations.



VINYL FLOOR APPLICATIONS

Tile and Slate Underlay must be fixed using nails at 75mm centres at all sheet edges and at 150mm centres in the middle of sheet as per nail dot marks. Over particle board, plywood and composite flooring products the nailing and adhesive application must be used. For tongue and groove timber or hardwood floors the nailing alone is suitable for underlay fixing.

Nails should be driven absolutely flush with the surface of the sheet. Failure to do this can result in nail heads showing through vinyl floor coverings. Do not damage sheet face with hammer indentations. Where minor height variations (3mm or less) occur, these may be levelled out by filling with self levelling compounds instead of sanding. Ensure the sheet is dry prior to applying the vinyl adhesive.

Flush-sand all joints and any other surface roughness/nailed areas with a belt or rotary sander. The Makita belt sander No.9401 fitted with a No.401 vacuum cleaner or other similar belt sander is recommended. Use medium grit sanding belts/papers. All sanders must be fitted with effective dust collection devices - see recommended Safe Working Practices.

Failure to provide an absolutely smooth, ridge and indentation-free underlay surface may cause unsightly blemishes to appear through the vinyl or cork floor coverings.

Typical fixing of Underlay Sheet for vinyl floors:

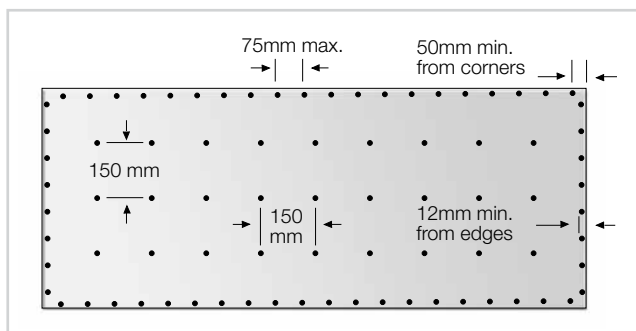

Fix sheets from the centre outwards using the pre-marked nailing pattern, driving fasteners flush with the sheet surface. Use 25 x 2.5mm underlay nails or the 25 x 3.06mm coil nail.



MOVEMENT JOINTS

Provide movement joints where floor dimensions exceed 5m in one or both directions or where existing structural joints are located.

Position joints symmetrically about the centre of the floor as shown below.

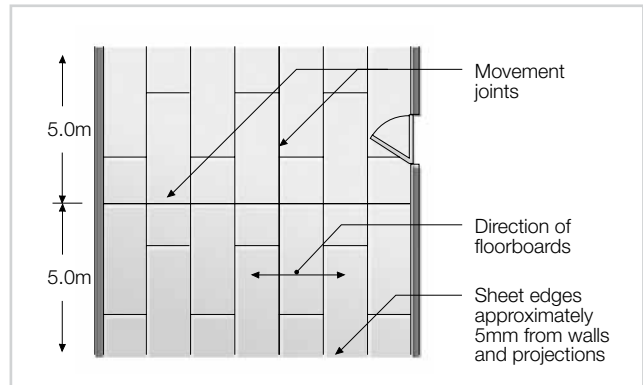

Also provide movement joints where there are changes of direction, such as an L-shaped room, and at doorways where the tiled surface is carried through to the next room as shown.

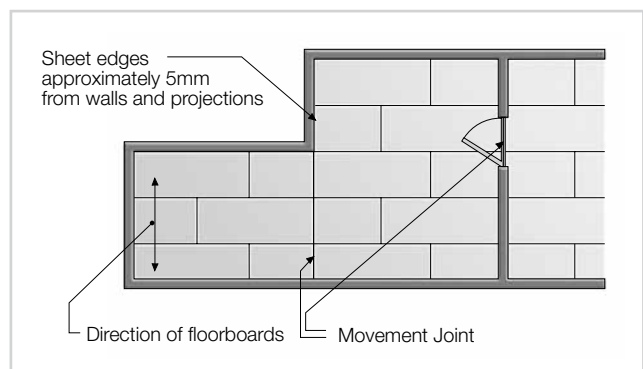

The movement joint in Underlay sheets must coincide with a joint in the tiles. Place a polyethylene foam-backing rod (PEF) in the bottom of the joint between the underlay sheets and tiles. Fill off the joint with a suitable sealant.

The width of the movement joint should be approximately equal to the width of the grout line. It is important that the movement joints be carried through to the top of the floor surface i.e. they should not be covered by tiles. Do not fill movement joints in Tile and Slate Underlay with grout.

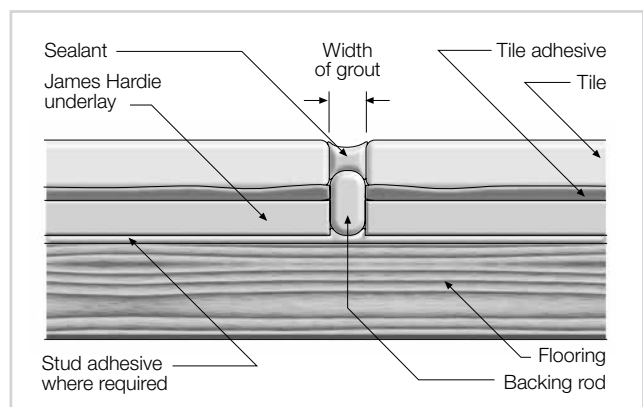

4.2 HARDIEPANEL COMPRESSED SHEET INSTALLATION

SUBSTRATE PREPARATION

For floor joist spacing and size refer to section 3.

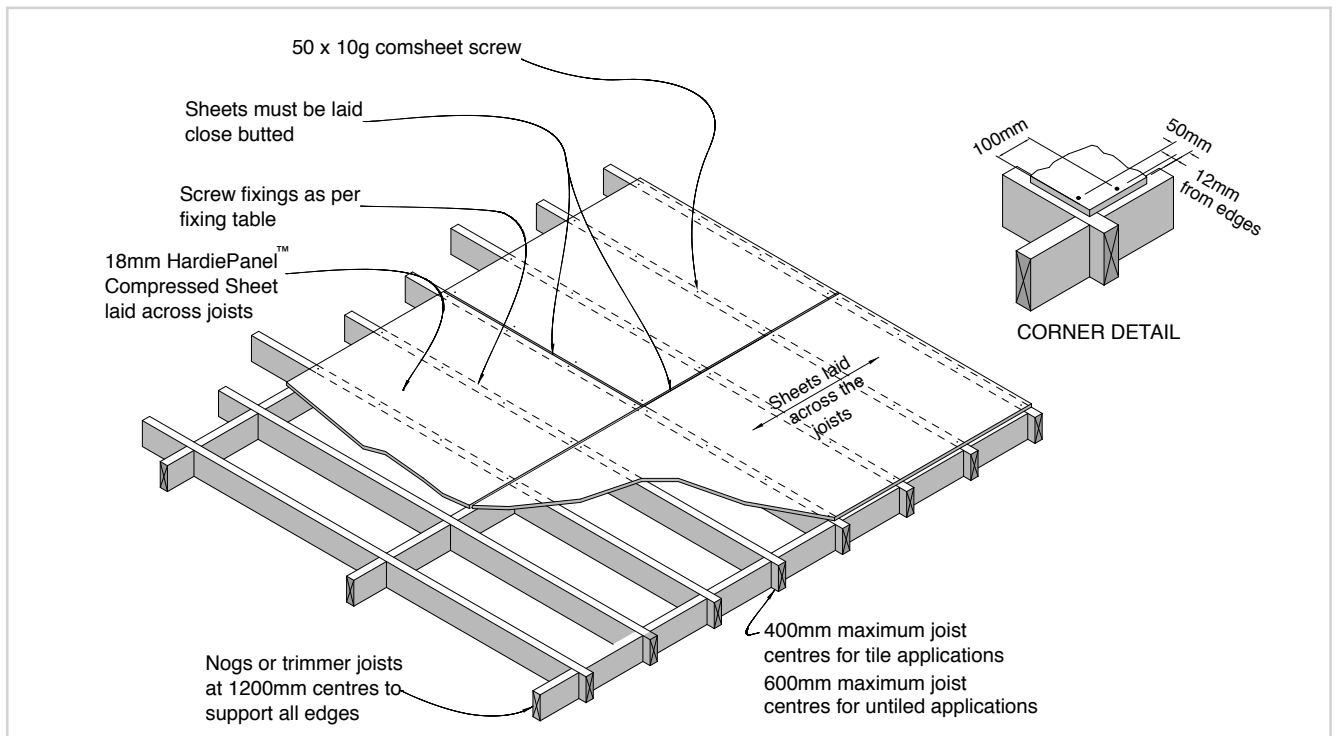

Figure 1: Layout

Table 4

HardiePanel Compressed Sheet fixing	
JOIST SPACING CENTRES	FASTENER MAXIMUM SPACING CENTRES
400mm	400mm
600mm	300mm

Sheet joints must be located on the centre line of a joist or nog. This is to ensure sufficient edge clearance for screw fixing of adjoining sheets along the sheet edges. Refer to Figure 2.

Sheet edges must be butted tightly together for tiling applications.

HardiePanel Compressed sheets must be dry before fixing to framing.

Long-span joists must also be avoided as excessive deflections can occur.

HardiePanel Compressed sheet is structurally stronger when sheets are laid across the joists, i.e. the long side of the sheet at right angles to the joists (refer Figure 1).

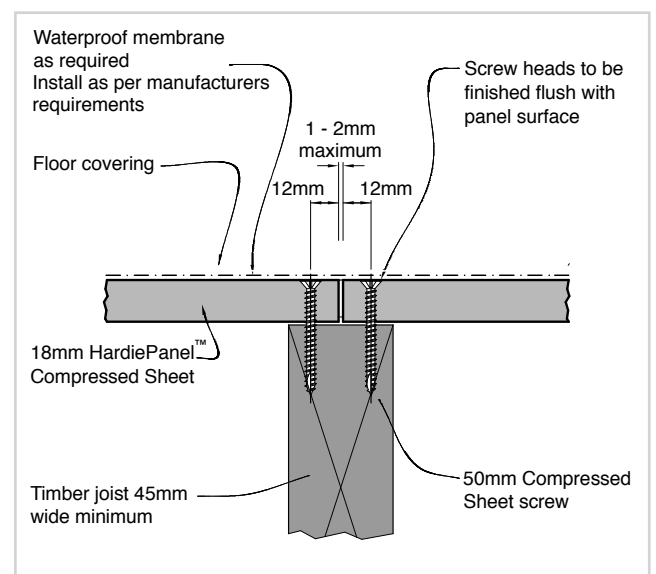

Figure 2: Joint detail

5 Internal floor — wet area

Screw fixings centres must be as per the fixing table to all timber framing (refer Table 3). Generally the screw fixings are countersunk 2-3mm below the panel surface. For tiling applications direct over HardiePanel Compressed Sheet the screws can be driven flush with the sheet surface for tiling in dry areas or where the tile adhesive is applied directly over the sheet.

In wet areas that have a waterproof membrane applied the screw fixings must be countersunk 2-3mm maximum below the surface and flushed over with two-part epoxy resin before applying the membrane.

All screw holes in the 18mm sheet must be pre-drilled using the 18mm Tungsten Carbide Drill Bit (refer Figure 3). Holes must be drilled with 1mm clearance over the diameter of the screw to be used.

Fix HardiePanel Compressed with 10g x 50mm Comsheet stainless steel screws (refer Figure 3).

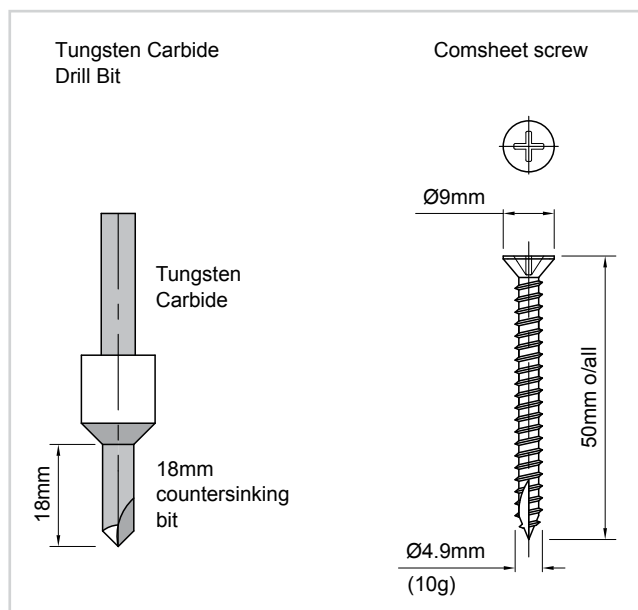

Figure 3: Drill bit and screw

5.1 TILE AND SLATE UNDERLAY INSTALLATION

Refer to clause 4.1 Step 1 to 3 for the installation of Tile and Slate Underlay.

Waterproofing Membrane

A waterproofing membrane must be applied over Tile and Slate Underlay before applying tile adhesive.

Continue to lay tiles as per clause 4 step 4.

5.2 HARDIEPANEL COMPRESSED SHEET INSTALLATION

Refer to clause 4.2 for the installation of HardiePanel Compressed Sheet.

Waterproofing Membrane

A waterproofing membrane must be applied over HardiePanel Compressed Sheet before applying tile adhesive.

When tiles are continuous over the butt joint of HardiePanel Compressed floors, all joints must be tied with a 200mm-wide strip of fibreglass mesh embedded into the membrane.

5.3 CONTROL JOINTS

In internal applications a control joint must be provided in HardiePanel Compressed Sheet at 5m in both directions or at locations where dimensions change. Refer Figure 4. Control joints must be continued through the tiles and filled with a flexible sealant.

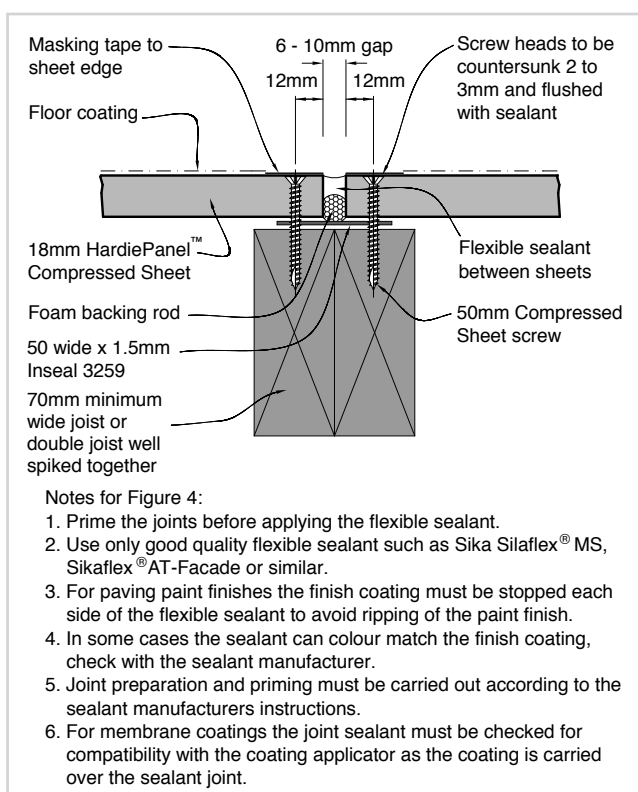

Figure 4: Control joint

6 External deck

Refer to Section 3 for framing information / requirements.

HardiePanel Compressed Sheet is resistant to intermittent wetting. However, for durability and long term performance the sheet must have the finishes applied within 90 days of installation. For external decks the minimum fall is 1 to 40.

Finishes over HardiePanel Compressed Sheet can be tile, marble, slate or granite stone finishes, suitable paving paints or specialist applied coatings such as Ados, Nuplex or Dulux. A water proofing membrane must be applied over the HardiePanel Compressed Sheet before applying tiles where there is a living / habitable space under the deck.*

**check with your local Territorial Authority for their specific requirements in this area.*

6.1 HARDIEPANEL COMPRESSED SHEET FIXING

The HardiePanel Compressed Sheet must be dry before fixing to framing. Fixings must be as per Table 4.

The sheets must be laid across the floor joists. All deck and floor applications must be modelled to suit individual sheet sizes.

Control Joint

A control joint must be provided around a bay size of 3600 x 2400mm maximum. Where the deck is less than 2000mm wide, a control joint must be provided at 4200mm maximum centres along its length.

6.2 JOINTING OPTIONS

There are two methods of sheet joint set out:

Method 1: Sealant Control Joint

The sheets can be installed using a perimeter sealant control joint (refer Figure 5 or 6) around all sheet edges. Sheet edges are to be spaced minimum 6mm to a maximum of 10mm to allow for the perimeter flexible control joint detail. The tiles are then cut and modelled to suit the sheet size. A full depth sealant joint as in Figure 5 and Figure 6 is required. Sheet edges must be painted / sealed before applying the sealant.

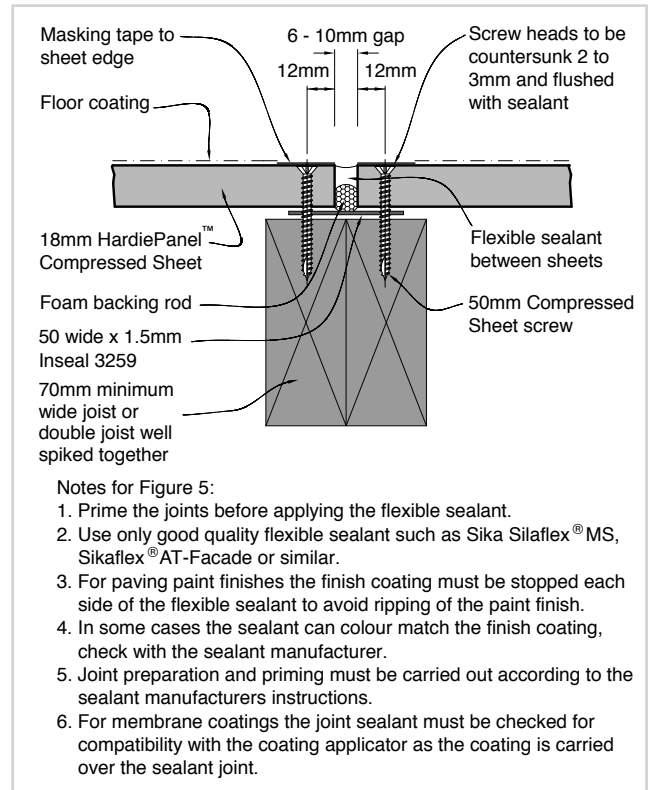

Figure 5: Un-tiled control joint detail

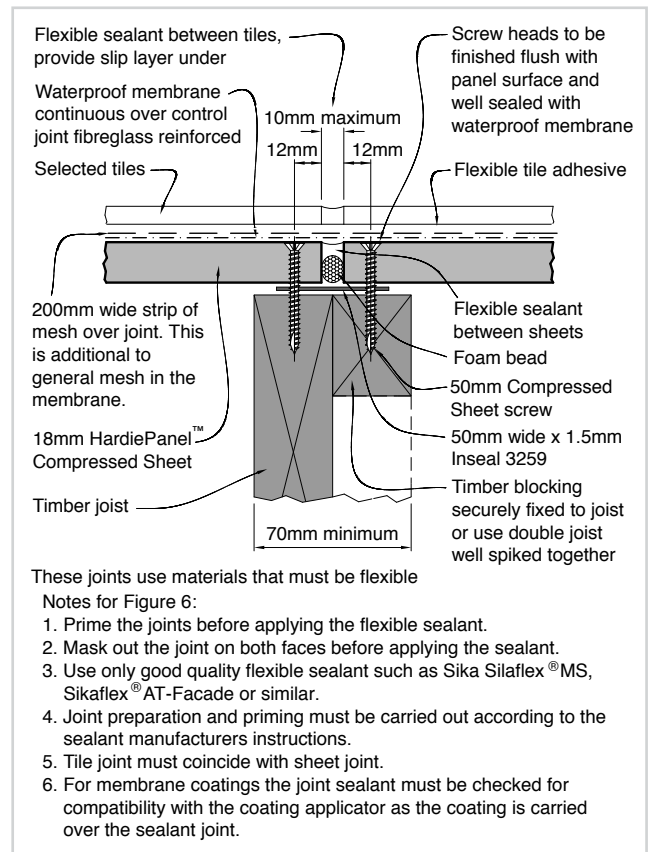

Figure 6: Tiled control joint detail

Method 2: Rigid Bonded Joints

To achieve a bigger bay size area the sheets can be bonded together to form a rigid joint to achieve a bay size of 3600 x 2400mm as shown in Figure 7 and Figure 8. The tiles can be laid continuously over the rigid joints to form a maximum bay size of 3600 x 2400mm. When the tiled area is greater than the maximum bay size (3600 x 2400mm), a silicone control joint as per Figure 6 must be placed between the adjacent bonded panel. Control joints must continue through the tiles.

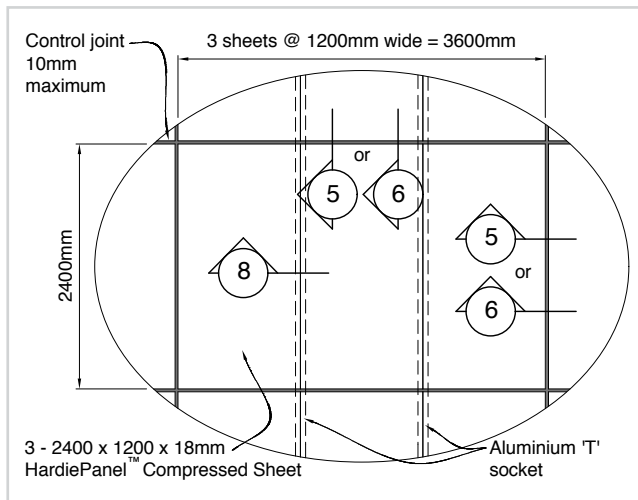

Figure 7: Bay size — 3600 x 2400mm

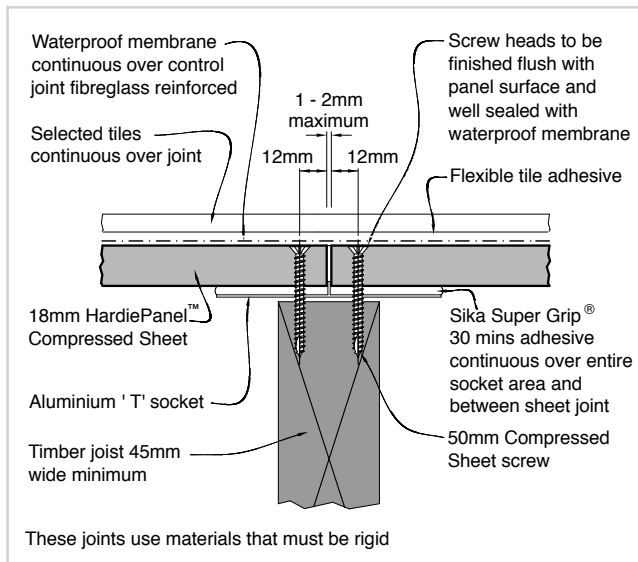

Figure 8: Rigid joint detail

The expressed joints between all adjacent sheets function as control joints.

When covering sheets with paving paints, pebbles or a similar finish; these expansion joints must be carried up through the finishes.

Sheets must be screw fixed at maximum centres as per fixing table to all timber or steel framing (refer Figure 9). The edge distance is 12mm. Keep fixings minimum 50mm one direction and 100mm the other direction for corners. Fix the sheet from the centre working towards the outside to avoid drumminess.

HardiePanel Compressed Sheet must be laid across the joists i.e. the long side of the sheet at right angles to the joists (refer Figure 9).

Screw holes and countersunk holes must be drilled in one operation with the 18mm tungsten carbide drill bits available from stockists of James Hardie building products (refer HardiePanel Compressed Sheet accessories). The recommended drill speed for this bit is 400 to 560 rpm. Incorrect speed will snap the drill bit.

For fixing HardiePanel Compressed Sheet to timber framing use 50mm x 10g stainless steel pozi-drive Compressed Sheet screws available from stockists of James Hardie building products (refer HardiePanel Compressed Sheet accessories).

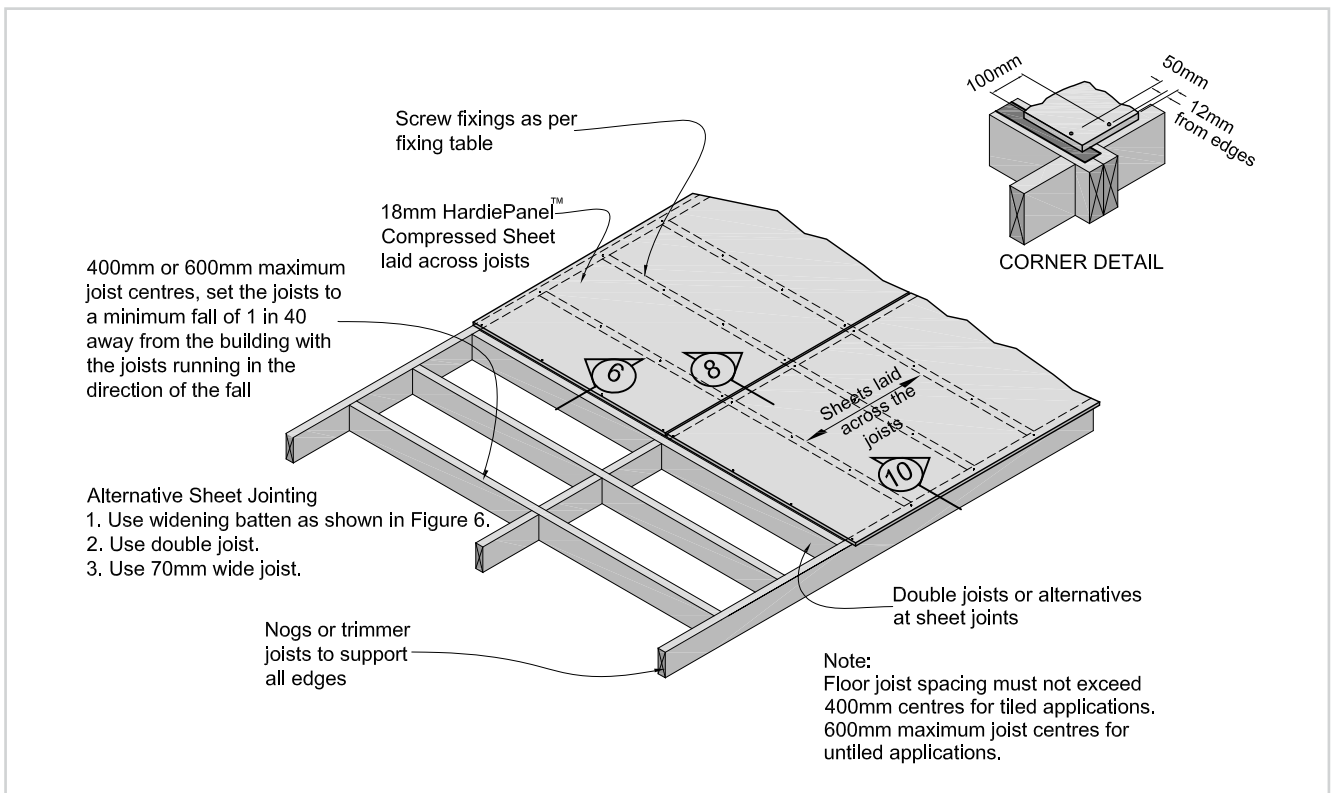

Figure 9: Timber support and screw fixing

Generally, for tiling applications the Compressed Sheet screw head can be finished flush with the sheet surface but when a waterproofing membrane is to be applied the screw head is required to be countersunk below the sheet surface by 2mm min and fill over with an epoxy. Ensure compatibility with the waterproof membrane.

6.3 DECK JACKS

Deck jacks can be used with HardiePanel Compressed Sheet at 600mm centres maximum. The HardiePanel Compressed Sheet must be waterproofed on all sides and edges.

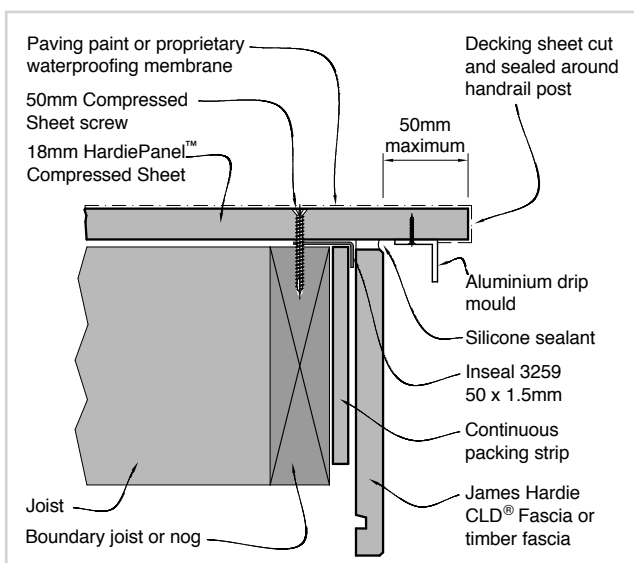

Figure 10: Decking edge for non-tiled decks

7 Waterproofing

For all internal wet areas and exterior tile applications HardiePanel Compressed Sheets must be waterproofed in accordance with AS 3740 prior to tiling.

All sheet fixing must be completed to this specification before the primer and waterproofing membrane is applied.

Ensure the sheet is dry and free from surface dust and dirt before applying the primer.

The primer and waterproof membrane can be applied directly over the countersunk screw/flush nail heads. Ensure compatibility.

Apply a coat of suitable primer to the entire surface of the Tile and Slate Underlay / HardiePanel Compressed Sheet. Follow the manufacturer's instructions for coverage areas, and specific instructions. For suitable Waterproofing Manufacturers refer to Table 5.

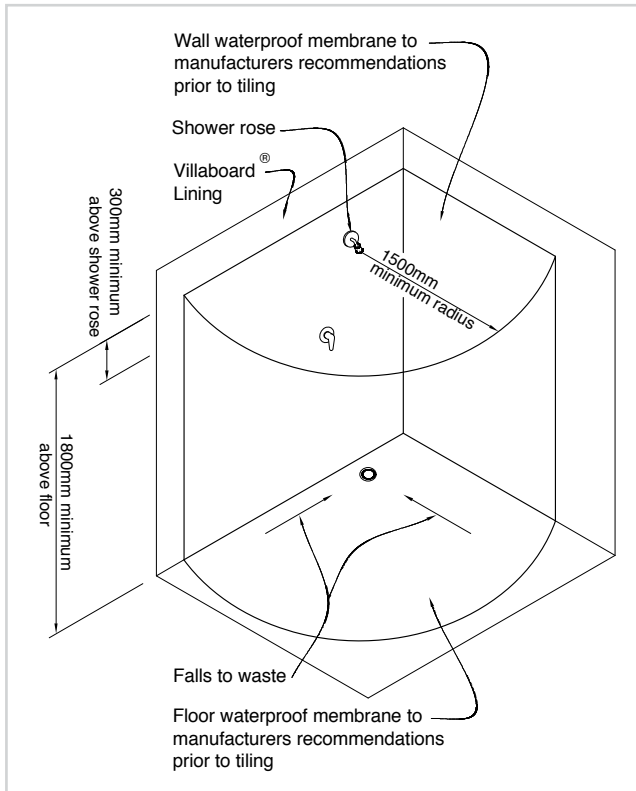
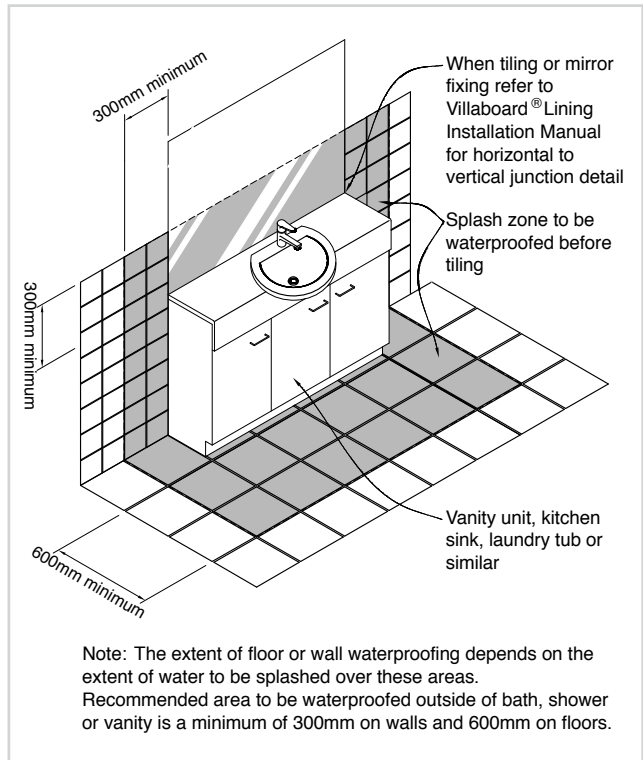

Figure 11: Sealing around splash zones (showers)



Note: The extent of floor or wall waterproofing depends on the extent of water to be splashed over these areas. Recommended area to be waterproofed outside of bath, shower or vanity is a minimum of 300mm on walls and 600mm on floors.

Figure 12: Sealing around splash zones (vanities)

Prime sheet and apply coat of selected waterproof membrane with associated mesh as per waterproof manufacturers' recommendations.

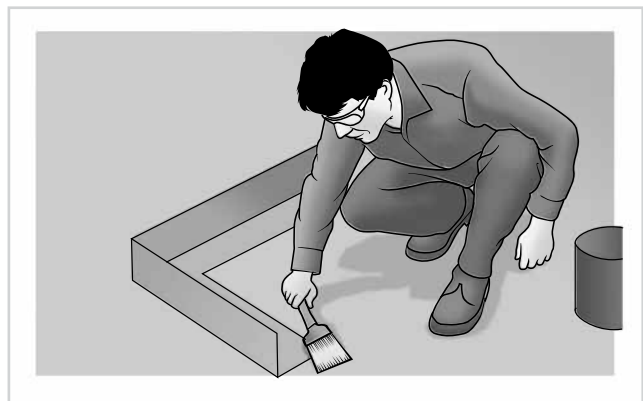

Figure 13: Waterproofing floor to wall

8 Finishes

GENERAL

James Hardie flooring must be finished with a suitable floor covering to suit the intended application. For the suitability and installation requirements of floor coverings, check with the manufacturer.

Screeds

Where the application requires the flooring have falls created and this was unable to be achieved within the floor framing prior to flooring being installed, a 15mm minimum mortar bed screed may be used. An alternative is an epoxy mortar screed. The surface of the flooring must be thoroughly clean and dry prior to applying the screed as per manufacturer's instructions. To prevent cracking of floor tiles, the mortar bed must be reinforced over all joints in flooring sheets.

Selection of Tiles

The following brief notes do not cover all aspects of tiling. Further advice should be sought from specialists in these areas.

The importance of choosing the proper tile for a given environment cannot be stressed enough. Manufacturer's catalogues indicate the recommended uses and limitations of their products and should be consulted when unsure.

Tile adhesives

Because of possible differential movement between tiles and the Tile and Slate Underlay and the HardiePanel Compressed Sheet, only approved flexible adhesive and grouts must be used.

Refer to the adhesive manufacturers' specifications for sheet preparation before applying the flexible tile adhesive.

The recommended brands of waterproof membranes and tile adhesives are shown in Table 5. It is essential that all tile systems such as primers, waterproofing membranes, exterior grade flexible adhesives and grouts are all supplied by the same manufacturer to ensure compatibility of products and warranty protection.

Marble Floor Tiles

Marble is a relatively weak material and if used as a flooring material should be isolated from structural movement. This can be achieved by modifying the flooring system to incorporate a fully reinforced mortar bed as shown in Figure 15. It is recommended that the services of a tradesperson experienced in the application of marble tiles be obtained.

Tiling Practice

Refer to the selected tile manufacturer for complete details regarding the laying and fixing of the ceramic tiles, marble, slate and granite stone. Reference can also be made to the BRANZ publication "Good Tiling Practice".

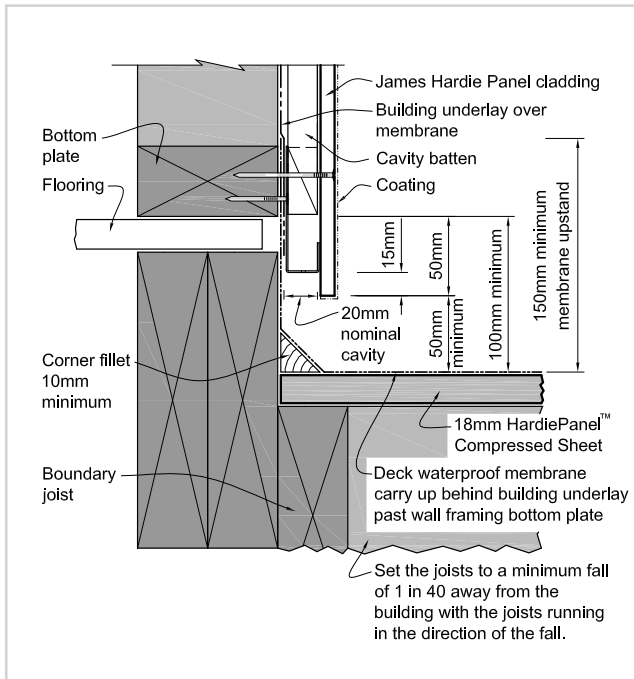

Figure 14: Waterproofing deck to wall junction with cavity

Table 5

Recommended waterproofing membranes/tile adhesives
Mapei NZ Ltd
Superflex® 'Ardex Liquid Membranes' from Ardex NZ Ltd
Flexi-Seal® from Flexco (NZ) Ltd
DuroSet™ and DuroQik™ from Waterproofing Systems Ltd
Strataflex from Protective Surfaces Limited
ASA Waterproofing Membranes from Bostik

For coverage information of the selected waterproof membrane for walls and floors refer to manufacturer's recommendations. Waterproofing membranes must be applied in accordance with their manufacturers' requirements.

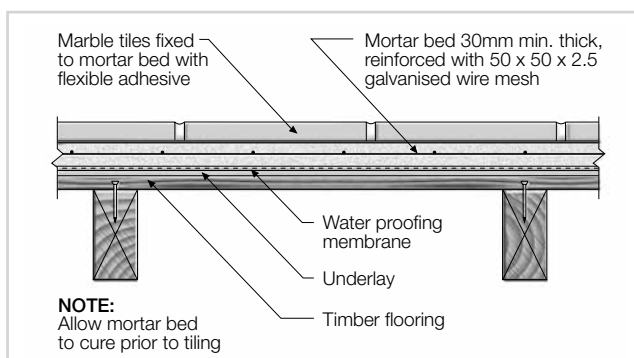

Figure 15: Marble floor tiles

9 Maintenance

Regular checks and maintenance of components including sealant, grout and waterproofing must be done as required by the manufacturer.

Certain floor coverings have protective clear coatings which enhance the durability and prolong the life of such floor coverings. For maintenance requirements check with both the floor covering and coating manufacturer.

10 Product information

GENERAL

James Hardie flooring products are cellulose fibre reinforced cement building products. The basic composition is Portland cement, ground sand, cellulose fibre and water.

James Hardie floorings are manufactured to AS/NZS 2908.2 'Cellulose- Cement Products Part 2: Flat Sheets' (ISO 8336 'Fibre Cement Flat Sheets').

James Hardie flooring products are classified Type B, Category 3 in accordance with AS/NZS 2908.2 'Cellulose-Cement Products'.

PRODUCT MASS

Based on equilibrium moisture content the approximate mass of:

- Tile and Slate Underlay is 8.87 kg/m².
- HardiePanel Compressed Sheet is 33 kg/m².

NOTE: Dry HardiePanel Compressed sheets can vary in moisture content with the seasons and prevailing weather conditions. As a guide a dry sheet can vary between 4% moisture content in summer and 12% in winter.

DURABILITY

Resistance to moisture/rotting

James Hardie floorings have demonstrated resistance to permanent moisture induced deterioration (rotting) by having passed the following tests in accordance with AS/NZS 2908.2:

- Water permeability (Clause 8.2.2)
- Warm water (Clause 8.2.4)
- Heat rain (Clause 6.5)
- Soak dry (Clause 8.2.5)

Resistance to Fire

James Hardie floorings are deemed to be non-combustible.

James Hardie floorings have been tested by CSIRO and are classified as a Group 1 material.

James Hardie floorings have the following early fire hazard indices (tested to AS 1530 Part 3).

Early fire hazard indices	
Flammability (FI)	0
Spread of Flame Index (SFD)	0
Heat evolved index	0
Smoke developed index (SDI)	0 - 1

Product warranty

February 2013

WARRANTY: James Hardie New Zealand ("James Hardie") warrants for a period of 15 years from the date of purchase that the Tile and Slate Underlay and HardiePanel™ Compressed Sheet (the "Product"), will be free from defects due to defective factory workmanship or materials and, subject to compliance with the conditions below, will be resistant to cracking, rotting, fire and damage from termite attacks to the extent set out in James Hardie's relevant published literature current at the time of installation. James Hardie warrants for a period of 15 years from the date of purchase that the accessories supplied by James Hardie will be free from defects due to defective factory workmanship or materials. Nothing in this document shall exclude or modify any legal rights a customer may have under the Consumer Guarantees Act or otherwise which cannot be excluded or modified at law.

CONDITIONS OF WARRANTY:

The warranty is strictly subject to the following conditions:

- a) James Hardie will not be liable for breach of warranty unless the claimant provides proof of purchase and makes a written claim either within 30 days after the defect would have become reasonably apparent or, if the defect was reasonably apparent prior to installation, then the claim must be made prior to installation;
- b) this warranty is not transferable;
- c) the Product must be installed and maintained strictly in accordance with the relevant James Hardie literature current at the time of installation and must be installed in conjunction with the components or products specified in the literature. Further, all other products, including coating and jointing systems, applied to or used in conjunction with the Product must be applied or installed and maintained strictly in accordance with the relevant manufacturer's instructions and good trade practice;
- d) the project must be designed and constructed in strict compliance with all relevant provisions of the current NZBC, regulations and standards;
- e) the claimant's sole remedy for breach of warranty is (at James Hardie's option) that James Hardie will either supply replacement product, rectify the affected product or pay for the cost of the replacement or rectification of the affected product;
- f) James Hardie will not be liable for any losses or damages (whether direct or indirect) including property damage or personal injury, consequential loss, economic loss or loss of profits, arising in contract or negligence or howsoever arising. Without limiting the foregoing James Hardie will not be liable for any claims, damages or defects arising from or in any way attributable to poor workmanship, poor design or detailing, settlement or structural movement and/or movement of materials to which the Product is attached, incorrect design of the structure, acts of God including but not limited to earthquakes, cyclones, floods or other severe weather conditions or unusual climatic conditions, efflorescence or performance of paint/coatings applied to the Product, normal wear and tear, growth of mould, mildew, fungi, bacteria, or any organism on any Product surface or Product (whether on the exposed or unexposed surfaces);
- g) all warranties, conditions, liabilities and obligations other than those specified in this warranty are excluded to the fullest extent allowed by law;
- h) if meeting a claim under this warranty involves re-coating of Products, there may be slight colour differences between the original and replacement Products due to the effects of weathering and variations in materials over time.

Disclaimer: The recommendations in James Hardie's literature are based on good building practice, but are not an exhaustive statement of all relevant information and are subject to conditions (c), (d), (f) and (g) above. James Hardie has tested the performance of the Tile and Slate Underlay and HardiePanel™ Compressed Sheet when installed in accordance with the Flooring Installation Manual, in accordance with the standards and verification methods required by the NZBC and those test results demonstrate the product complies with the performance criteria established by the NZBC. However, as the successful performance of the relevant system depends on numerous factors outside the control of James Hardie (e.g. quality of workmanship and design) James Hardie shall not be liable for the recommendations made in its literature and the performance of the relevant system, including its suitability for any purpose or ability to satisfy the relevant provisions of the NZBC, regulations and standards, as it is the responsibility of the building designer to ensure that the details and recommendations provided in the relevant James Hardie installation manual are suitable for the intended project and that specific design is conducted where appropriate.

Copyright February 2013. © James Hardie New Zealand. TM and ® denotes a Trademark or Registered Mark owned by James Hardie Technology Limited.



Ask James Hardie™

Call 0800 808 868

www.jameshardie.co.nz